



Technical User Guide

Omnipod® 5 Automated Insulin Delivery System



Contacts and Important Information

Customer Care - 24 hours/7 days

Website: omnipod.com

Address: Insulet Corporation, 100 Nagog Park, Acton MA 01720, USA

Controller Model: PDM-M001-G-MM

Serial Number: _____

Omnipod® 5 Automated Insulin Delivery System

Start Date: _____

© 2024 Insulet Corporation. Insulet, Omnipod, the Omnipod logo, and SmartAdjust are trademarks or registered trademarks of Insulet Corporation. All rights reserved. The Bluetooth word mark and logos are registered trademarks owned by Bluetooth SIG, Inc. and any use of such marks by Insulet Corporation is under licence. Dexcom and Dexcom G6 are registered trademarks of Dexcom, Inc. and used with permission. The Sensor housing, FreeStyle, Libre, and related brand marks are marks of Abbott and used with permission. All other trademarks are the property of their respective owners. The use of third-party trademarks does not constitute an endorsement or imply a relationship or other affiliation.

Patent information at www.insulet.com/patents.

PT-000981-AW REV 04 11/24

Contents

Section 1: Before You Begin	1
Chapter 1: Introduction	3
1.1 Welcome to Your Omnipod® 5 System	4
1.2 About This Technical User Guide	6
1.3 Indications For Use	6
1.4 Compatible Insulins	7
1.5 General Warnings	8
1.6 General Precautions	11
Section 2: Omnipod 5 Pump Features	17
Omnipod 5 Pump Important Safety Information	19
Chapter 2: System Terminology and Navigation	29
2.1 Terminology	30
2.2 Using the Touchscreen and Entering Information	33
Chapter 3: Omnipod 5 System Overview	37
3.1 Omnipod 5 App and Sensor Communication	39
3.2 Omnipod 5 App	41
3.3 Lock Screen and Security	42
3.4 Status Bar	44
3.5 Home Screen	45
3.6 Home Screen Main Menu	53
3.7 Notifications and Messages	54
3.8 Manual and Automated Mode Overview	56
Chapter 4: Setting Up Your Omnipod 5 Application	59
4.1 Setting Up Your Account	60
4.2 Preparing for Your Training	60
4.3 General Settings on Insulet-provided Controller	62
4.4 Basal Settings	66
4.5 Bolus Settings	70
4.6 Your App Setup is Complete	74
4.7 Saving Your Settings for Reference	75
Chapter 5: Activating and Changing Your Pod	77
5.1 Beginning the Pod Activation Process	78
5.2 Setting Up a New Pod	80
5.3 Fill the Syringe with Insulin	80
5.4 Filling, Activating, Applying and Starting the Pod	81

5.5	Checking Your Infusion Site	89
5.6	Switching to Automated Mode	90
5.7	Deactivating an Active Pod	91
5.8	More Information about Pod Use	92
Chapter 6: Basal Programmes		95
6.1	About Basal Programmes	96
6.2	Reviewing All Basal Programmes	96
6.3	Creating New Basal Programmes	97
6.4	Editing a Basal Programme	97
6.5	Deleting a Basal Programme	98
6.6	Switching to a Different Basal Programme	99
6.7	Basal Insulin Delivery	99
Chapter 7: Temporary Basal Rates and Presets		101
7.1	About Temporary Basal Rates	102
7.2	Starting a Temp Basal	103
7.3	Cancelling a Temp Basal or Temp Basal Preset	105
7.4	Creating a New Temp Basal Preset	105
7.5	Editing a Temp Basal Preset	106
7.6	Deleting a Temp Basal Preset	107
7.7	Temporary Basal Rates Delivery	107
Chapter 8: Blood Glucose Readings		111
8.1	About Blood Glucose Readings	112
8.2	Entering Your Blood Glucose Reading	113
8.3	High and Low Blood Glucose Readings	114
Chapter 9: Pausing and Starting Insulin Delivery		117
9.1	Pausing Insulin Delivery	118
9.2	Methods to Temporarily Pause Insulin Delivery in Manual Mode ..	119
9.3	Starting Insulin Delivery	120
Chapter 10: Changing Settings		121
10.1	General Settings	122
10.2	Reminder Settings	126
10.3	Basal and Temp Basal Settings	129
Chapter 11: Browsing Your History and Records		131
11.1	About Your Recent History and Past Records	132
11.2	Viewing the Sensor Graph	132
11.3	Sensor Graph States	133
11.4	History Information Overview	135
11.5	Calculations for History Summaries	138
11.6	History Details Section	139

Chapter 12: Managing Software Updates	145
12.1 Insulet-provided Controller	146
Chapter 13: Alarms, Action and Reminder Notifications	149
13.1 Types of Alarms and Notifications	151
13.2 Alarms and Notifications Screen	152
13.3 Sounds and Vibrations	153
13.4 Informational Sounds and Vibrations	154
13.5 Responding to Alarms	156
13.6 Hazard Alarm List	158
13.7 Advisory Alarm List	166
13.8 Action Item Notification List	171
13.9 Silencing Unresolved Alarms	179
13.10 Responding to Reminder Notifications	180
13.11 Reminder Notifications List	181
Chapter 14: Taking Care of Your Controller and Pod	183
14.1 Pod and Insulin Storage and Care	184
14.2 Controller Storage and Care	185
14.3 Controller Battery Care	188
Chapter 15: Living with Diabetes	191
15.1 Infusion Site Checks	192
15.2 Being Aware of Your Glucose	193
15.3 Travelling and Holidays	194
15.4 Avoiding Lows, Highs, and Diabetic Ketoacidosis	196
15.5 Handling Special Situations	204
Section 3: SmartBolus Calculator	207
SmartBolus Calculator Important Safety Information	209
Chapter 16: Delivering a Bolus	211
16.1 Delivering a Manual Bolus	212
16.2 Delivering Immediate and Extended Boluses	213
16.3 Tracking the Progress of a Bolus	214
Chapter 17: Delivering a Bolus with the SmartBolus Calculator .	217
17.1 About the SmartBolus Calculator	218
17.2 Entering Meal Information	220
17.3 Entering a Blood Glucose Reading or Using a Sensor Glucose Value	220
17.4 Insulin on Board (IOB)	222
17.5 Adjustments to Your Calculation	223
17.6 Delivering an Immediate Bolus	224

Contents

17.7 Delivering an Extended Bolus.....	225
17.8 Bolus Settings	227
Chapter 18: Understanding SmartBolus Calculator Calculations	233
18.1 The SmartBolus Calculator	234
18.2 SmartBolus Calculator Examples.....	248
Section 4: Using a Sensor with Omnipod 5	251
Sensor Important Safety Information	253
Chapter 19: Using a Dexcom G6 Sensor with Omnipod 5.....	255
19.1 Dexcom G6 Overview	256
19.2 Dexcom G6 Sensor Placement.....	257
19.3 Using the Dexcom G6 with Omnipod 5	258
19.4 Sensor Glucose Values.....	259
19.5 Sensor Glucose Trend Arrows	260
19.6 Communication Messages.....	261
19.7 About Connecting Dexcom G6 to the Pod	263
19.8 Connecting the Dexcom G6 during Initial Pod Setup	263
19.9 Connecting the Dexcom G6 Transmitter	264
19.10 Disconnecting the Transmitter from the Pod.....	265
19.11 Switching to Dexcom G6 from Another Sensor.....	265
Chapter 20: Using a FreeStyle Libre 2 Plus Sensor with Omnipod 5	269
20.1 FreeStyle Libre 2 Plus Sensor Overview.....	271
20.2 FreeStyle Libre 2 Plus Sensor Application and Placement.....	273
20.3 Using a FreeStyle Libre 2 Plus Sensor with the Omnipod 5 App ..	275
20.4 Sensor Glucose Trends and Indicators	281
20.5 FreeStyle Libre 2 Plus Sensor Communication and Problem Messages	283
20.6 About Connecting a FreeStyle Libre 2 Plus Sensor to the Pod....	290
20.7 Connecting a FreeStyle Libre 2 Plus Sensor during Initial Pod Setup.....	291
20.8 Sensor Removal: Expiry and Deletion.....	295
20.9 Switching to FreeStyle Libre 2 Plus from Another Sensor	298
Section 5: Automated Mode	301
Automated Mode Important Safety Information.....	303
Chapter 21: About Automated Mode.....	305
21.1 About Automated Mode.....	306
21.2 About the Sensor in Automated Mode	309
21.3 Bolus Settings and Importance of a Bolus	310

21.4 Pod Adaptivity	311
21.5 About Automated Mode: Limited	312
21.6 Automated Delivery Restriction	314
Chapter 22: Switching Between Manual Mode and Automated Mode	317
22.1 Switching from Manual Mode to Automated Mode	318
22.2 Switching from Automated Mode to Manual Mode	320
Chapter 23: Activity Feature	321
23.1 About the Activity Feature	322
23.2 Starting the Activity Feature	323
23.3 Cancelling the Activity Feature.....	323
Chapter 24: Automated Mode Alarms	325
24.1 Advisory Alarm List.....	326
Chapter 25: Omnipod 5 Clinical Studies	331
25.1 Studies in Children, Adolescents and Adults with Type 1 Diabetes	332
25.2 Studies in Very Young Children with Type 1 Diabetes	347
Section 6: Additional Information	357
Chapter 26: Troubleshooting	359
26.1 Omnipod 5 Pump FAQs.....	360
26.2 SmartBolus Calculator FAQs.....	365
26.3 Sensor FAQs	366
26.4 Automated Mode FAQs	372
26.5 Pod Communication Issues – “Try Again”	374
26.6 About Keeping Your Omnipod 5 Controller Nearby.....	377
26.7 Device Complaints	378
26.8 Factory Mode and Boot Mode	379
Appendix	381
Index	409
My Settings	414

This page intentionally left blank.

BEFORE YOU BEGIN

- 1** Introduction



This page intentionally left blank.

CHAPTER 1

Introduction

Contents

1.1 Welcome to Your Omnipod® 5 System	4
The Omnipod 5 System Features	4
1.2 About This Technical User Guide	6
1.3 Indications For Use	6
Indications for use.....	6
Contraindications	7
1.4 Compatible Insulins	7
1.5 General Warnings	8
1.6 General Precautions	11
Potential Risks	13
Important User Information.....	14
Emergency Kit.....	15

1 Introduction

1.1 Welcome to Your Omnipod® 5 System

The Omnipod® 5 System is the first wearable, on-body, tubeless, automated insulin delivery system, when used with either the Dexcom G6® Continuous Glucose Monitoring System or the FreeStyle Libre 2 Plus Flash Glucose Monitoring System, to continuously adapt and automatically deliver insulin according to your personal needs. The Omnipod 5 System consists of a tubeless insulin Pod and the Omnipod® 5 App on an Insulet-provided Controller.

The Omnipod 5 System Features

- **Pod:** The Pod provides continuous subcutaneous insulin delivery. It may be worn for up to 3 days and can be filled with up to 200 units of U-100 rapid-acting insulin (minimum 85 units).
- **No tubing:** There is no tubing with the Pod, allowing you to place the Pod almost anywhere you would give yourself an injection. The Pod is waterproof for depths up to 7.6 m (25 ft) for up to 60 minutes (IP28).
- **Omnipod® 5 App:** The Omnipod 5 App allows you to select a basal profile, Target Glucose and bolus settings, activate and deactivate the Pod, connect with a compatible glucose Sensor, and select insulin delivery mode. The Omnipod 5 App comes installed on an Insulet-provided Controller.
- **Two compatible glucose Sensors:** The Omnipod 5 System is designed to work with either the Dexcom G6 Continuous Glucose Monitoring (CGM) System or the FreeStyle Libre 2 Plus Flash Glucose Monitoring System. Either system must be obtained separately. Sensor glucose values and trends are used for automated insulin delivery in Automated Mode, as well as bolus calculations in both Automated and Manual Mode.
 - The Dexcom G6 Transmitter must be connected and active within the Dexcom G6 App to send sensor glucose values to the Pod.
 - The FreeStyle Libre 2 Plus Sensor must be started by, connected, and active within the Omnipod 5 App to send sensor glucose values to the Pod.
- **Two modes of operation:** The Omnipod 5 System provides the following modes of operation: Automated and Manual. The Omnipod 5 System enables you to switch between modes when required conditions are met. The System behaves differently depending on which mode you select.
 - **Automated Mode:** Each Pod contains SmartAdjust™ technology that adjusts insulin every 5 minutes to bring your glucose value to

your customised glucose target, or Target Glucose. The adjustment is based on a prediction of where your glucose will be 60 minutes in the future and considers your sensor glucose value and trend, Adaptive Basal Rate, and insulin that is still working in your body.

- **Manual Mode:** The Omnipod 5 System delivers insulin based on user-defined Basal Programmes. During Manual Mode, there is no automated adjustment of insulin delivery.
- **Activity feature:** While in Automated Mode, you can enable the Activity feature in times when you need less insulin, for example, when you are getting ready to exercise. When the Activity feature is enabled, the system gives less insulin and aims for a Target Glucose of 8.3 mmol/L (150 mg/dL).
- **SmartBolus Calculator:** If you are planning to eat or if your glucose is high, the SmartBolus Calculator can suggest a bolus amount of insulin based on your individual settings, entered values, and sensor glucose value and trend when available. The SmartBolus Calculator allows for the immediate delivery of the bolus insulin in both Automated and Manual Mode. In Manual Mode, the SmartBolus Calculator also allows for an Extended Bolus. The Extended Bolus can be customised to deliver the bolus dose over a period of time.
- **Keeping Track of sensor Glucose and Insulin:** The Omnipod 5 System records up to 90 days of information, including basal delivery, bolus doses, carbohydrates, alarms and glucose-related data. In Automated Mode, the system records automated insulin delivery and corresponding sensor glucose values every 5 minutes. The Home screen features a Sensor Graph that allows for reference of your sensor glucose values and displays some information about insulin delivery.
- **Pod Site tracker:** When activating a new Pod, the System provides the option to track the site on which you have applied a Pod. This allows you to reference past Pod sites when deciding where to place your next Pod.

1 Introduction

1.2 About This Technical User Guide

The purpose of this *Technical User Guide* is to assist you with the features and functions of the Omnipod 5 System. It provides step-by-step instructions on how to properly operate the System, as well as important warnings and cautions to ensure your safety during use.

Note: This *Technical User Guide* is intended for use only with the Insulet-provided Controller with the Omnipod 5 App, model PDM-M001-G-MM. To learn which version of the Insulet-provided Controller you have, turn it over. If you see “PDM-M001-G-MM” on the back of the Controller, this is the correct *Technical User Guide*. If you do not see it, contact Customer Care. Using an incorrect *Technical User Guide* can lead to improper use of the Omnipod 5 System.

Note: Screen images shown in this *Technical User Guide* are examples only and are not suggestions for user settings. Always consult with your healthcare provider to determine the appropriate settings for you.

Healthcare and treatment are complex subjects requiring the services of qualified healthcare providers. This *Technical User Guide* is informational only and not intended as medical or healthcare advice or recommendations to be used for diagnosis, treatment, or for any other individual needs. This *Technical User Guide* is not a substitute for medical or healthcare advice, recommendations, and/or services from a qualified healthcare provider. This *Technical User Guide* may not be relied upon in any way in connection with your personal healthcare, related decisions, and treatment. All such decisions and treatment should be discussed with a qualified healthcare provider who is familiar with your individual needs.

1.3 Indications For Use

Indications for use

The **Omnipod 5 Automated Insulin Delivery System** is a single hormone insulin delivery system intended to deliver U-100 insulin subcutaneously for the management of type 1 diabetes in persons aged 2 and older requiring insulin.

The Omnipod 5 System is intended to operate as an automated insulin delivery system when used with compatible Continuous Glucose Monitors (CGM).

When in Automated Mode, the Omnipod 5 System is designed to assist people with type 1 diabetes in achieving glycaemic targets set by their healthcare providers. It is intended to modulate (increase, decrease or suspend) insulin delivery to operate within predefined threshold values using current and predicted sensor glucose values to maintain blood

glucose at variable Target Glucose levels, thereby reducing glucose variability. This reduction in variability is intended to lead to a reduction in the frequency, severity and duration of both hyperglycaemia and hypoglycaemia.

The Omnipod 5 System can also operate in a Manual Mode that delivers insulin at set or manually adjusted rates.

The Omnipod 5 System is intended for single-patient use. The Omnipod 5 System is indicated for use with NovoLog®/NovoRapid®, Humalog®, Admelog®/Insulin lispro Sanofi®, Trurapi®/Insulin aspart Sanofi®, and Kirsty®.

Contraindications

The Omnipod 5 System is NOT recommended for people who:

- Are unable to monitor glucose as recommended by their healthcare provider.
- Are unable to maintain contact with their healthcare provider.
- Are unable to use the Omnipod 5 System according to instructions.
- Are taking hydroxyurea and using Dexcom G6 as it could lead to falsely elevated sensor glucose values and result in over-delivery of insulin, which can lead to severe hypoglycaemia.
- Do NOT have adequate hearing and/or vision to allow recognition of all functions of the Omnipod 5 System, including alerts, alarms, and Reminders.

Device components including the Pod, Dexcom G6 Sensor, Dexcom G6 Transmitter, and FreeStyle Libre 2 Plus Sensor must be removed before Magnetic Resonance Imaging (MRI). In addition, the Controller should be placed outside the procedure room. Exposure to MRI can damage the components.

1.4 Compatible Insulins

NovoLog®/NovoRapid®, Humalog®, Admelog®/Insulin lispro Sanofi®, Trurapi®/Insulin aspart Sanofi®, and Kirsty®.

1 Introduction

1.5 General Warnings

Warning: Read all the instructions provided in this *Technical User Guide* before using the Omnipod 5 System. Monitor your glucose with the guidance of your healthcare provider. Undetected hyperglycaemia or hypoglycaemia can develop without proper monitoring.

Warning: DO NOT start to use your system or change your settings without adequate training and guidance from your healthcare provider. Initiating and adjusting settings incorrectly can result in over-delivery or under-delivery of insulin, which could lead to hypoglycaemia or hyperglycaemia. Settings that impact insulin delivery mainly include: Pod Shut-Off, basal rate(s), Max Basal Rate, Max Bolus, Correction Factor(s), Insulin-to-Carb (IC) Ratio(s), Minimum Glucose for Calculations, Target Glucose and Correct Above, and Duration of Insulin Action.

Warning: DO NOT rely upon this *Technical User Guide* in any way in connection with your personal healthcare, related decisions, and treatment. This *Technical User Guide* is informational only and not intended as medical or healthcare advice or recommendations to be used for diagnosis, treatment, or for any other individual needs. This *Technical User Guide* is not a substitute for medical or healthcare advice, recommendations, and/or services from a qualified healthcare provider. All such decisions and treatment should be discussed with a qualified healthcare provider who is familiar with your individual needs.

Warning: DO NOT use the Omnipod 5 System if you are unable or unwilling to use it as instructed by this *Technical User Guide* and your healthcare provider. Failure to use this system as intended could result in over-delivery or under-delivery of insulin, which can lead to hypoglycaemia or hyperglycaemia.

Warning: ALWAYS keep an emergency kit with you to quickly respond to any diabetes emergency or in the case that your Omnipod 5 System stops working. Always carry supplies to perform a Pod change should you need to replace your Pod at any time.

Warning: ALWAYS dispose of the Pod according to local waste disposal guidelines. The Pod is considered biohazardous after use and can potentially transmit infectious diseases.

Warning: DO NOT use SmartAdjust technology in pregnant women, critically ill patients or those on dialysis. The safety of SmartAdjust technology has not been evaluated in these populations. Consult with your healthcare provider if any of these conditions apply to you before using SmartAdjust technology.

Warning: DO NOT use the Omnipod 5 System if you do not have adequate vision and/or hearing to recognise all functions of the Omnipod 5 System including alerts, alarms and Reminders according to instructions.

Warning: ONLY use rapid-acting U-100 NovoLog®/NovoRapid® (insulin aspart), Humalog® (insulin lispro), Admelog®/Insulin lispro Sanofi® (insulin lispro), Trurapi®/Insulin aspart Sanofi® (insulin aspart), and Kirsty® (insulin aspart) insulin in the Omnipod 5 System as they have been tested and found to be safe for use with this system. NovoLog/NovoRapid, Humalog, Admelog/Insulin lispro Sanofi, Trurapi/Insulin aspart Sanofi, and Kirsty are compatible with the Omnipod 5 System for use up to 72 hours (3 days). Follow your healthcare provider's directions on how often to replace the Pod.

Warning: AVOID administering insulin, such as by injection or inhalation, while wearing an active Pod as this could result in hypoglycaemia. The Omnipod 5 System cannot track insulin that is administered outside of the system. Consult your healthcare provider about how long to wait after manually administering insulin before you start Automated Mode.

Warning: AVOID changing your SmartBolus Calculator settings before consulting with your healthcare provider. Incorrect changes could result in over-delivery or under-delivery of insulin, which can lead to hypoglycaemia or hyperglycaemia. Settings that impact bolus calculations mainly include: Max Bolus, Minimum Glucose for Calculations, Correct Above, Correction Factor(s), Insulin-to-Carb (IC) Ratio(s), Duration of Insulin Action and Target Glucose.

Warning: ALWAYS follow your healthcare provider's guidance on appropriate glucose monitoring to avoid hyperglycaemia and hypoglycaemia.

Warning: Glucose below 3.9 mmol/L (70 mg/dL) may indicate hypoglycaemia (low glucose). Glucose above 13.9 mmol/L (250 mg/dL) may indicate hyperglycaemia (high glucose). Follow your healthcare provider's suggestions for treatment.

Warning: ALWAYS promptly treat hypoglycaemia. Glucose at or below 3.1 mmol/L (55 mg/dL) indicates significant hypoglycaemia (very low glucose). If left untreated, this could lead to seizure, loss of consciousness or death. Follow your healthcare provider's recommendations for treatment.

Warning: ALWAYS promptly treat glucose below 3.9 mmol/L (70 mg/dL) (hypoglycaemia) according to your healthcare provider's recommendations. Symptoms of hypoglycaemia include weakness, sweating, nervousness, headache or confusion. If left untreated, hypoglycaemia can lead to seizure, loss of consciousness or death.

Warning: DO NOT wait to treat hypoglycaemia (low glucose) or symptoms of hypoglycaemia. Even if you cannot check your glucose, waiting to treat symptoms could lead to severe hypoglycaemia, which can lead to seizure, loss of consciousness or death.

Warning: ALWAYS promptly treat hyperglycaemia (high glucose) according to your healthcare provider's recommendations. Symptoms of hyperglycaemia include fatigue, thirst, excess urination or blurry vision. If left untreated, hyperglycaemia can lead to diabetic ketoacidosis (DKA) or death.

1 Introduction

Warning: DO NOT wait to treat DKA. If left untreated, DKA can quickly lead to breathing difficulties, shock, coma or death.

Warning: ALWAYS treat “LOW” or “HIGH” sensor glucose values and blood glucose readings according to your healthcare provider’s recommendations. These values can indicate potentially serious conditions requiring immediate medical attention. If left untreated, these situations can quickly lead to diabetic ketoacidosis (DKA), shock, coma or death.

Warning: NEVER drive yourself to the emergency department if you need emergency medical care. Ask a friend or family member to take you to the emergency department or call an ambulance.

Warning: ALWAYS be aware of your current sensor glucose value, trust how your body feels and do not ignore symptoms of high and low glucose. Even though insulin delivery adjusts automatically in Automated Mode, with the goal of bringing your glucose level to your defined Target Glucose, severe hypoglycaemia or hyperglycaemia may still occur.

If your sensor glucose values do not match your symptoms, ALWAYS check your blood glucose using a BG meter and consider treatment and/or Sensor calibration if necessary. ALWAYS switch to Manual Mode if you feel you are receiving inaccurate sensor glucose values.

- Erroneously high sensor glucose values can cause excessive insulin delivery, leading to severe hypoglycaemia, seizure, loss of consciousness or death.
- Erroneously low sensor glucose values can cause prolonged insulin suspension, leading to hyperglycaemia, DKA or death.

If you are having symptoms that are not consistent with your blood glucose readings and you have followed all instructions described in this *Technical User Guide*, contact your healthcare provider.

Warning: ALWAYS make sure you are using the Sensor as per the manufacturer’s instructions. Do not extend the Sensor wear beyond the recommended duration and do not start a Sensor past its Use-By date. The Omnipod 5 System relies on accurate, current sensor glucose values to determine your insulin needs. Incorrect use of the Sensor could result in over-delivery or under-delivery of insulin, which could lead to hypoglycaemia or hyperglycaemia.

Warning: Do NOT use the Omnipod 5 System with the Dexcom G6 Sensor if you are taking hydroxyurea, a medication used in the treatment of diseases including cancer and sickle cell anaemia. Your Dexcom G6 sensor glucose values could be falsely elevated and could result in over-delivery of insulin, which can lead to severe hypoglycaemia.

Warning: ALWAYS respond to Hazard Alarms as soon as they occur. Pod Hazard Alarms indicate that insulin delivery has stopped. Failure to respond to a

Hazard Alarm could result in under-delivery of insulin, which can lead to hyperglycaemia.

Warning: ALWAYS monitor your glucose and follow your healthcare provider's treatment guidelines when you stop receiving insulin due to a blockage (occlusion). Not taking action promptly could result in under-delivery of insulin, which can lead to hyperglycaemia or diabetic ketoacidosis (DKA) (see “ Blockage Detected” on page 158).

Warning: ALWAYS keep your Controller safe and within your control to ensure others cannot make changes to your insulin therapy. Unintended changes to your insulin delivery could result in over-delivery or under-delivery of insulin, which can lead to hypoglycaemia or hyperglycaemia. Be careful who you share your Controller PIN with.

Warning: DO NOT use the Omnipod 5 System at low atmospheric pressure (below 700 hPA). You could encounter such low atmospheric pressures at high elevations, such as when mountain climbing or living at elevations above 3,000 m (10,000 ft). Change in atmospheric pressure can also occur during take-off with air travel. Unintended insulin delivery can occur if there is expansion of tiny air bubbles that may exist inside the Pod. This can result in hypoglycaemia. It is important to check your glucose frequently when flying to avoid prolonged hypoglycaemia.

Warning: DO NOT use the Omnipod 5 System in oxygen-rich environments (greater than 25% oxygen), which include home or surgical areas that use supplementary oxygen and hyperbaric chambers. Hyperbaric, or high pressure, chambers are sometimes used to promote healing of diabetic ulcers or to treat carbon monoxide poisoning, certain bone and tissue infections and decompression sickness. Exposure to oxygen-rich environments could result in combustion of the Pod or Omnipod 5 Controller, which can cause severe burns to the body.

Warning: DO NOT use the Omnipod 5 System in high-atmospheric-pressure environments (above 1,060 hPA), which can be found in a hyperbaric chamber. Hyperbaric, or high-pressure, chambers, are sometimes used to promote healing of diabetic ulcers, or to treat carbon monoxide poisoning, certain bone and tissue infections, and decompression sickness. Exposure to high-atmospheric-pressure environments can damage your Pod and Omnipod 5 Controller, which could result in under-delivery of insulin, which can lead to hyperglycaemia.

1.6 General Precautions

Caution: DO NOT use any component of the Omnipod 5 System (Controller, Pod) if you suspect damage after an unexpected event such as dropping or hitting on a hard surface. Using damaged components may put your health at risk as the system may not be working properly. If you are unsure if one or more of your

1 Introduction

components are damaged, stop using the system and contact Customer Care for support.

Caution: ONLY use the Omnipod 5 System with authorised devices (Omnipod 5 App, Controller and Pod, and compatible Sensors). DO NOT attempt to use the Omnipod 5 System with unauthorised devices. Attempting to use the Omnipod 5 System with unauthorised devices could interrupt your insulin delivery and put your health and safety at risk.

Caution: Connect ONLY to trusted Wi-Fi networks with your Controller. AVOID connecting to public Wi-Fi networks, such as those found in airports, coffee shops, etc., as these networks are not secure and could result in exposing your Controller to malware. DO NOT connect to public Wi-Fi networks during first-time setup of your Omnipod 5 System.

Caution: ALWAYS activate a new Pod in a timely manner. Waiting too long between Pod changes could result in under-delivery of insulin, which can lead to hyperglycaemia. If another Pod is not available, use a different insulin delivery method.

Caution: DO NOT navigate away from the Omnipod 5 App while you are in the process of making changes to your insulin delivery settings. If you leave the App before the setting change comes into effect, the system will continue to use your last saved settings. As a result, you may continue with therapy settings that you did not intend. If you are unsure about whether your changes were saved, review your settings.

Caution: AVOID leaving your Controller in a place that would prevent you from hearing alarms and notifications from your Omnipod 5 App. Delivery of insulin in Manual Mode or Automated Mode continues as programmed if you move away from your Controller.

Caution: ALWAYS respond to Pod Expired, Low Pod Insulin, and Pod Shut-Off Advisory Alarms when they occur. These alarms escalate to Hazard Alarms if no action is taken. When Hazard Alarms occur, insulin delivery stops.

Caution: ALWAYS be aware of possible changes to your time zone when travelling. If you do not update your time zone, your insulin therapy will be delivered based on your old time zone, which may cause disruptions in your insulin delivery schedule and inaccurate history logs. Talk to your healthcare provider about how to manage your insulin delivery while travelling between time zones.

Caution: You cannot use the Dexcom G6 receiver with the Omnipod 5 System because the Omnipod 5 System is compatible only with the G6 App on a smartphone.

Caution: ALWAYS check your glucose frequently during amusement park rides and flying, or other situations where sudden changes or extremes of air pressure, altitude or gravity may be occurring. Though the Omnipod 5 System is safe to use at atmospheric pressures typically found in aeroplane cabins during flight, the atmospheric pressure in an aeroplane cabin can change during flight, which may affect the Pod's insulin delivery. Rapid changes in altitude and gravity, such as those typically found on amusement park rides or flight take-off and landing, can affect insulin delivery, leading to possible hypoglycaemia or injury. If needed, follow your healthcare provider's treatment instructions.

Potential Risks

- The Omnipod 5 System uses sensor glucose values and trends to calculate insulin delivery. If the sensor glucose values are inaccurate, the System could deliver an inaccurate dose of insulin, which can lead to hypoglycaemia or hyperglycaemia.
- The Omnipod 5 System uses information and settings that you enter to calculate and adjust insulin delivery. If the information you enter is inaccurate, or if you don't give the System information about carbs and glucose, the System could deliver an inaccurate dose of insulin, which can lead to hypoglycaemia or hyperglycaemia.
- Wearing a Pod might cause infection. Be aware of signs of infection, including: bleeding, pain and skin irritation, including redness. See your healthcare provider if irritation occurs.
- Kinks in the cannula or dislodging of the cannula can interrupt insulin delivery. Glucose that does not decrease after a bolus, or other unexplained high glucose, are signs of a blockage (occlusion) or other interruption in insulin delivery.
- Air bubbles in the Pod or cannula can affect insulin delivery. If there is a large amount of air in the Pod, the System could deliver an inaccurate dose of insulin, which can lead to hypoglycaemia or hyperglycaemia.
- Infusion site complications like scar tissue and infection can make insulin delivery less effective. Glucose that does not decrease after a bolus, or other unexplained high glucose, is a sign of ineffective insulin delivery.
- Hardware defects, software glitches and Pod failures can cause an interruption in insulin delivery. A Pod failure can lead to hyperglycaemia or diabetic ketoacidosis. Keep your Omnipod 5 Controller and smartphone on and nearby to ensure you are notified of recent insulin delivery and important alarms and messages.

Important User Information

Pay special attention to Warnings and Precautions in this *Technical User Guide*. The words “**Warning**” and “**Caution**” are displayed in red, bolded text.

The Omnipod 5 System is designed to work with either the Dexcom G6 CGM or FreeStyle Libre 2 Plus Sensor-based glucose monitors.

- To use the Dexcom G6 CGM with the Omnipod 5 System, you will need to obtain the Dexcom G6 Sensor, Transmitter, and Instructions for Use, and download the Dexcom G6 App on your personal smartphone.
- To use the FreeStyle Libre 2 Plus Sensor with the Omnipod 5 System, you will need to obtain FreeStyle Libre 2 Plus Sensors and the FreeStyle Libre 2 Plus Instructions for Use. If you are new to using a glucose Sensor, continue using your BG meter until you are familiar with Sensor usage.

If you are currently using the system without a Sensor, or if you are currently using a Sensor, it is still very important that you review all instructions in the Instructions for Use before using the system.

If you still have questions after reading the Instructions for Use, contact Customer Care 24 hours a day, 7 days a week.

Emergency Kit

Warning: ALWAYS keep an emergency kit with you to quickly respond to any diabetes emergency or in the case that your Omnipod 5 System stops working. Always carry supplies to perform a Pod change should you need to replace your Pod at any time.

Warning: NEVER drive yourself to the emergency department if you need emergency medical care. Ask a friend or family member to take you to the emergency department or call an ambulance.

Prepare an emergency kit to keep with you at all times. The kit should include:

- Several new, sealed Omnipod 5 Pods.
- A vial of rapid-acting U-100 insulin (see “1.5 General Warnings” on page 8 for insulins cleared for use in the Omnipod 5 Pod).
- Syringes or pens for injecting insulin.
- Glucose tablets or another fast-acting source of carbohydrate.
- Glucose Sensor supplies:
 - Dexcom G6 Sensors, Dexcom G6 Transmitter, and Dexcom G6 App.
 - FreeStyle Libre 2 Plus Sensors .
- Blood glucose test strips.
- Blood glucose meter.
- Ketone test strips.
- Lancing device and lancets.
- Alcohol prep swabs.
- Instructions from your healthcare provider about how much insulin to inject if delivery from the Pod is interrupted.
- A signed letter from your healthcare provider explaining that you need to carry insulin supplies and the Omnipod 5 System.
- Phone numbers for your healthcare provider and/or doctor in case of an emergency.
- Glucagon kit and written instructions for administering a glucagon dosage if you are unconscious (see “15.4 Avoiding Lows, Highs, and Diabetic Ketoacidosis” on page 196).

Tip: Ask your healthcare provider to help you develop plans for handling emergency situations, including what to do if you cannot reach your healthcare provider.

This page intentionally left blank.

OMNIPOD 5 PUMP FEATURES

- Omnipod 5 Pump
Important Safety Information
.....
- 2 System Terminology and Navigation
.....
- 3 Omnipod 5 System Overview
.....
- 4 Setting Up Your Omnipod 5 Application
.....
- 5 Activating and Changing Your Pod
.....
- 6 Basal Programmes
.....
- 7 Temporary Basal Rates and Presets
.....
- 8 Blood Glucose Readings
.....
- 9 Pausing and Starting Insulin Delivery
.....
- 10 Changing Settings
.....
- 11 Browsing Your History and Records
.....
- 12 Managing Software Updates
.....
- 13 Alarms, Action and Reminder Notifications
.....
- 14 Taking Care of Your Controller and Pod
.....
- 15 Living with Diabetes

This page intentionally left blank.

Omnipod 5 Pump Important Safety Information

Pump Warnings

Omnipod 5 System Settings and Training

Warning: DO NOT start to use your system or change your settings without adequate training and guidance from your healthcare provider. Initiating and adjusting settings incorrectly can result in over-delivery or under-delivery of insulin, which could lead to hypoglycaemia or hyperglycaemia. Settings that impact insulin delivery mainly include: Pod Shut-Off, basal rate(s), Max Basal Rate, Max Bolus, Correction Factor(s), Insulin-to-Carb (IC) Ratio(s), Minimum Glucose for Calculations, Target Glucose and Correct Above, and Duration of Insulin Action.

Insulin

Warning: ONLY use rapid-acting U-100 NovoLog[®]/NovoRapid[®] (insulin aspart), Humalog[®] (insulin lispro), Admelog[®]/Insulin lispro Sanofi[®] (insulin lispro), Trurapi[®]/Insulin aspart Sanofi[®] (insulin aspart), and Kirsty[®] (insulin aspart) insulin in the Omnipod 5 System as they have been tested and found to be safe for use with this system. NovoLog/NovoRapid, Humalog, Admelog/Insulin lispro Sanofi, Trurapi/Insulin aspart Sanofi, and Kirsty are compatible with the Omnipod 5 System for use up to 72 hours (3 days). Follow your healthcare provider's directions on how often to replace the Pod.

Warning: ALWAYS be prepared to inject insulin with an alternative method if insulin delivery from the Pod is interrupted. You are at increased risk for developing hyperglycaemia if insulin delivery is interrupted because the Pod only uses rapid-acting U-100 insulin. Failure to have an alternative method of insulin delivery can lead to very high glucose or diabetic ketoacidosis (DKA). Ask your healthcare provider for instructions on handling interrupted insulin delivery.

Warning: NEVER use insulin that is expired or cloudy in the Pod as it may be damaged. Using damaged or expired insulin could cause hyperglycaemia and put your health at risk.

Warning: AVOID administering insulin, such as by injection or inhalation, while wearing an active Pod as this could result in hypoglycaemia. The Omnipod 5 System cannot track insulin that is administered outside of the system. Consult your healthcare provider about how long to wait after manually administering insulin before you start Automated Mode.

Important Safety Information

Omnipod 5 System

Warning: Device components including the Pod, Dexcom G6 Sensor, Dexcom G6 Transmitter, and FreeStyle Libre 2 Plus Sensor may be affected by strong radiation or magnetic fields. Device components must be removed (and the Pod and Sensor should be disposed of) before X-ray, Magnetic Resonance Imaging (MRI) or Computed Tomography (CT) scan (or any similar test or procedure). In addition, the Controller should be placed outside the procedure room. Exposure to X-ray, MRI or CT treatment can damage these components. Check with your healthcare provider on Pod removal guidelines.

Warning: DO NOT expose any Omnipod 5 System products or supplies to extreme temperatures as this results in them not functioning properly. Store all Omnipod 5 System products and supplies, including unopened Pods, in a cool, dry place.

Pod

Warning: Do NOT use a Pod if you are sensitive to or have allergies to acrylic adhesives, or have fragile or easily damaged skin. Applying a Pod under these circumstances could put your health at risk.

Warning: ALWAYS dispose of the Pod according to local waste disposal guidelines. The Pod is considered biohazardous after use and can potentially transmit infectious diseases.

Warning: DO NOT allow small children access to small parts, such as the Pod and its accessories, including the tab. Small parts could be swallowed and pose a choking hazard. If ingested or swallowed, these small parts could cause internal injury or infection.

Warning: NEVER inject large bubbles or pockets of air when filling the Pod with insulin. Air in the system takes up space where insulin should be and can affect insulin delivery. Doing so could result in over-delivery or under-delivery of insulin, which can lead to hypoglycaemia or hyperglycaemia.

Warning: NEVER use a Pod if, while you are filling the Pod, you feel significant resistance while pressing the plunger down on the fill syringe. Do not try to force the insulin into the Pod. Significant resistance may indicate that the Pod has a mechanical defect. Using this Pod could result in under-delivery of insulin, which can lead to hyperglycaemia.

Warning: DO NOT apply a Pod if you see the cannula is extended beyond the adhesive backing after the tab on the Pod is removed. This cannula cannot be inserted, resulting in under-delivery of insulin, which could lead to hyperglycaemia.

Warning: ALWAYS check the infusion site often to make sure the cannula is properly inserted and secured to the Pod. Verify that there is no wetness or scent of insulin, which may indicate that the cannula has been dislodged. An improperly inserted, loose or dislodged cannula could result in under-delivery of insulin, which can lead to hyperglycaemia.

Important Safety Information

Warning: NEVER inject insulin (or anything else) into the fill port while the Pod is on your body. Attempting to do so may result in over-delivery or under-delivery of insulin, which could lead to hypoglycaemia or hyperglycaemia.

Warning: DO NOT apply a new Pod until you have deactivated and removed the old Pod. A Pod that is not deactivated properly can continue to deliver insulin as programmed, putting you at risk of over-delivery of insulin, which can lead to hypoglycaemia.

Warning: DO NOT continue using an activated Pod that fails to beep during a diagnostic test. The Pod should be changed immediately. If the Omnipod 5 App fails to beep during a diagnostic test, contact Customer Care immediately. Continuing to use the Omnipod 5 System in these situations may put your health and safety at risk.

Warning: DO NOT expose a Pod to direct sunlight for long periods of time. Remove your Pod prior to using hot tubs, whirlpools or saunas. These conditions could expose the Pod to extreme temperatures and may also affect the insulin inside the Pod, which could lead to hyperglycaemia.

Warning: Do NOT expose your Pod to water at depths greater than 7.6 m (25 ft) or for longer than 60 minutes because damage to the Pod can occur. This could result in over-delivery or under-delivery of insulin, which can lead to hypoglycaemia or hyperglycaemia.

Warning: DO NOT use the Omnipod 5 System at low atmospheric pressure (below 700 hPA). You could encounter such low atmospheric pressures at high elevations, such as when mountain climbing or living at elevations above 3,000 m (10,000 ft). Change in atmospheric pressure can also occur during take-off with air travel. Unintended insulin delivery can occur if there is expansion of tiny air bubbles that may exist inside the Pod. This can result in hypoglycaemia. It is important to check your glucose frequently when flying to avoid prolonged hypoglycaemia.

Warning: DO NOT use the Omnipod 5 System in oxygen-rich environments (greater than 25% oxygen), which include home or surgical areas that use supplementary oxygen and hyperbaric chambers. Hyperbaric, or high-pressure, chambers are sometimes used to promote healing of diabetic ulcers or to treat carbon monoxide poisoning, certain bone and tissue infections and decompression sickness. Exposure to oxygen-rich environments can result in combustion of the Pod or Omnipod 5 Controller, which can cause severe burns to the body.

Important Safety Information

Warning: DO NOT use the Omnipod 5 System in high-atmospheric-pressure environments (above 1,060 hPA), which can be found in a hyperbaric chamber. Hyperbaric, or high-pressure, chambers are sometimes used to promote healing of diabetic ulcers or to treat carbon monoxide poisoning, certain bone and tissue infections and decompression sickness. Exposure to high-atmospheric-pressure environments can damage your Pod and Omnipod 5 Controller, which could result in under-delivery of insulin, which can lead to hyperglycaemia.

Controller

Warning: ALWAYS identify the Omnipod 5 App as yours before using it. Using someone else's Omnipod 5 App can result in incorrect insulin delivery for both of you.

Warning: ALWAYS keep your Omnipod 5 App secure and within your control to ensure that others cannot make changes to your insulin therapy, which can lead to hypoglycaemia or hyperglycaemia. Do not share your Controller PIN with anyone.

Warning: ALWAYS contact Customer Care if your Omnipod 5 System Controller is damaged and not working properly. If a Controller replacement is needed, ALWAYS consult with your healthcare provider to get instructions on using other backup insulin delivery methods, like insulin injections. Make sure to check your glucose frequently.

Warning: You will NOT be able to use the Omnipod 5 App if:

- You have not installed a required update to the Omnipod 5 App.
- An update for the Omnipod 5 App is not yet available to fix a known issue.

Use a different insulin delivery method. Failure to deactivate your Pod and use another form of insulin delivery could result in over-delivery or under-delivery of insulin. This can lead to hypoglycaemia or hyperglycaemia.

Alarms

Warning: You must use the Omnipod 5 App within 15 minutes of the onset of the Pod Shut-Off Advisory Alarm. If you do not respond to this alarm within this time, the Omnipod 5 App and Pod sound a Hazard Alarm and your Pod stops delivering insulin, which can lead to hyperglycaemia.

Warning: ALWAYS respond to Hazard Alarms as soon as they occur. Pod Hazard Alarms indicate that insulin delivery has stopped. Failure to respond to a Hazard Alarm could result in under-delivery of insulin, which can lead to hyperglycaemia.

Warning: ALWAYS monitor your glucose and follow your healthcare provider's treatment guidelines when you stop receiving insulin due to a blockage (occlusion). Not taking action promptly could result in under-delivery of insulin, which can lead to hyperglycaemia or diabetic

ketoacidosis (DKA) (see “ Blockage Detected” on page 158).

Glucose Monitoring

Warning: ALWAYS follow your healthcare provider's guidance on appropriate glucose monitoring to avoid hyperglycaemia and hypoglycaemia.

Warning: NEVER drive yourself to the emergency department if you need emergency medical care. Ask a friend or family member to take you to the emergency department or call an ambulance.

Warning: Glucose below 3.9 mmol/L (70 mg/dL) may indicate hypoglycaemia (low glucose). Glucose above 13.9 mmol/L (250 mg/dL) may indicate hyperglycaemia (high glucose). Follow your healthcare provider's suggestions for treatment.

Warning: ALWAYS promptly treat glucose below 3.9 mmol/L (70 mg/dL) (hypoglycaemia) according to your healthcare provider's recommendations. Symptoms of hypoglycaemia include weakness, sweating, nervousness, headache or confusion. If left untreated, hypoglycaemia can lead to seizure, loss of consciousness or death.

Warning: DO NOT wait to treat hypoglycaemia (low glucose) or symptoms of hypoglycaemia. Even if you cannot check your glucose, waiting to treat symptoms could lead to severe hypoglycaemia, which can lead to seizure, loss of consciousness or death.

Warning: ALWAYS promptly treat hyperglycaemia (high glucose) according to your healthcare provider's recommendations. Symptoms of hyperglycaemia include fatigue, thirst, excess urination or blurry vision. If left untreated, hyperglycaemia could lead to diabetic ketoacidosis (DKA) or death.

Warning: ALWAYS be aware of your current sensor glucose value, trust how your body feels and do not ignore symptoms of high and low glucose. Even though insulin delivery adjusts automatically in Automated Mode, with the goal of bringing your glucose level to your defined Target Glucose, severe hypoglycaemia or hyperglycaemia may still occur.

If your sensor glucose values do not match your symptoms, ALWAYS check your blood glucose using a BG meter and consider treatment and/or Sensor calibration if necessary. ALWAYS switch to Manual Mode if you feel you are receiving inaccurate sensor glucose values.

- Erroneously high sensor glucose values can cause excessive insulin delivery, leading to severe hypoglycaemia, seizure, loss of consciousness or death.
- Erroneously low sensor glucose values can cause prolonged insulin suspension, leading to hyperglycaemia, DKA or death.

If you are having symptoms that are not consistent with your blood glucose readings and you have followed all instructions described in this *Technical User Guide*, contact your healthcare provider.

Important Safety Information

Warning: ALWAYS treat “LOW” or “HIGH” sensor glucose values and blood glucose readings according to your healthcare provider’s recommendations. These values can indicate potentially serious conditions requiring immediate medical attention. If left untreated, these situations can quickly lead to diabetic ketoacidosis (DKA), shock, coma or death.

Pump Precautions

Omnipod 5 System

Caution: DO NOT use any component of the Omnipod 5 System (Controller, Pod) if you suspect damage after an unexpected event such as dropping or hitting on a hard surface. Using damaged components may put your health at risk as the system may not be working properly. If you are unsure if one or more of your components are damaged, stop using the system and contact Customer Care for support.

Caution: NEVER use a hairdryer or hot air to dry the Controller or Pod. Extreme heat can damage the electronics.

Caution: ALWAYS make sure your battery has adequate charge prior to installing a software update.

Caution: ALWAYS check your glucose frequently during amusement park rides and flying, or other situations where sudden changes or extremes of air pressure, altitude or gravity may be occurring. Though the Omnipod 5 System is safe to use at atmospheric pressures typically found in aeroplane cabins during flight, the atmospheric pressure in an aeroplane cabin can change during flight, which may affect the Pod’s insulin delivery. Rapid changes in altitude and gravity, such as those typically found on amusement park rides or flight take-off and landing, can affect insulin delivery, leading to possible hypoglycaemia or injury. If needed, follow your healthcare provider’s treatment instructions.

Caution: ALWAYS check your glucose frequently when you use very low basal rates. Checking your glucose frequently can alert you to the presence of a blockage (occlusion). Blockages can result in hyperglycaemia.

Caution: ALWAYS tap START INSULIN to start insulin delivery after a pause period has ended during Manual Mode use. Insulin delivery does not automatically start after a pause. If you do not start insulin delivery, you could develop hyperglycaemia.

Important Safety Information

Caution: ALWAYS be aware of possible changes to your time zone when travelling. If you do not update your time zone, your insulin therapy will be delivered based on your old time zone, which may cause disruptions in your insulin delivery schedule and inaccurate history logs. Talk to your healthcare provider about how to manage your insulin delivery while travelling between time zones.

Caution: DO NOT reset the Omnipod 5 App before checking with your healthcare provider. This will erase all of your settings, Adaptive Basal Rate and history, and require you to change your active Pod. Before resetting, make sure you have a current record of your settings and a new Pod with supplies to use when restarting the App.

Caution: AVOID storing Omnipod 5 System components and supplies in a place where children, pets or pests may access. Unintended access could result in damage to system parts or impact their sterility.

Pod

Caution: DO NOT use a Pod if the sterile packaging is open or damaged, the Pod has been dropped after removal from the package or the Pod is expired, as the Pod may not work properly and increase your risk of infection.

Caution: ALWAYS insert the fill syringe into the fill port and not into any other location on the Pod. Do not insert the fill syringe more than once into the fill port. Use only the fill syringe and needle that came with your Pod. The fill syringe is intended for single use only and should only be used with the Omnipod 5 System. Failure to follow the instructions above may result in damage to your Pod.

Caution: NEVER reuse the Pod or fill syringe or try to use a fill syringe that did not come with your Pod. Always dispose of the used Pod and fill syringe according to local disposal guidelines. Only use a new Pod with the fill syringe included with each Pod change. Always carry supplies to perform a Pod change should you need to replace your Pod at any time.

Caution: ALWAYS follow these steps in preparing your site. If your site is not cleaned properly or if your hands are dirty, you increase your risk of infection.

- Wash your hands.
- Clean the top of the insulin vial with an alcohol prep swab.
- Clean your infusion site with soap and water or an alcohol prep swab, and let it dry completely.
- Keep sterile materials away from any possible contamination.

Caution: ALWAYS apply the Pod as directed. If you are applying a Pod in a place that does not have a lot of fatty tissue, squeeze the skin around the Pod until after the cannula has been inserted. Blockages (occlusions) may result if you do not use this technique for lean areas.

Important Safety Information

Caution: ALWAYS rotate insulin infusion sites to help prevent infusion site complications like scar tissue and infection. Rotating insulin infusion sites reduces the risk of scarring. Using a site with scar tissue can lead to problems with insulin absorption.

Caution: ALWAYS check for signs of infection often. If an infusion site shows signs of infection:

- Immediately remove the Pod and apply a new Pod at a different infusion site.
- Contact your healthcare provider. Treat the infection according to instructions from your healthcare provider.

If you see blood in your cannula, check your glucose more frequently to ensure insulin delivery has not been affected. If you experience unexpected high glucose, change your Pod.

Caution: Use caution while cleaning the Pod on your body. Hold the Pod securely so the cannula does not kink and the Pod does not detach from your skin.

Caution: DO NOT use sprays, strong detergents, or solvents on or near your Pod. The use of spray sunscreen, DEET-containing bug spray, personal care sprays, and other aerosols, detergents, and strong chemicals on the Pod can irritate the infusion site or damage the Pod, increasing the risk that the Pod housing will crack. Pod damage may result in the ingress of external fluids which can impact the ability of the Pod to function properly. This may result in the over-delivery or under-delivery of insulin, which can lead to hypoglycemia or hyperglycemia.

Controller

Caution: AVOID turning Automatic Time Zone OFF on the Controller. If you turn Automatic Time Zone OFF, your Controller will not be able to detect when your device time zone and insulin delivery time zone do not match. Delivering insulin based on a different time zone than your local time may cause errors in insulin delivery and data logging, which can lead to hypoglycaemia or hyperglycaemia.

Caution: ALWAYS plug in and charge your Controller when you see the low-battery message. If the battery charge becomes critically low, the Controller turns itself off, and you will not receive a low-battery Hazard Alarm. Without the use of the Controller, you will not be able to make changes to your insulin delivery, which could result in over-delivery or under-delivery of insulin, which can lead to hypoglycaemia or hyperglycaemia.

Caution: DO NOT expose your Controller battery to high heat $>30^{\circ}\text{C}$ ($>86^{\circ}\text{F}$) during storage and $>40^{\circ}\text{C}$ ($>104^{\circ}\text{F}$) during use. Do not puncture, crush or apply pressure to your battery. Failure to follow these instructions could result in an explosion, fire, electric shock, damage to the Controller or battery, or battery leakage.

Caution: DO NOT expose your Controller to extreme temperatures while in storage or during use. Extreme heat or cold can cause the Controller to malfunction. Extreme heat is defined as $>30^{\circ}\text{C}$ (86°F) during storage and $>40^{\circ}\text{C}$ (104°F) during use. Extreme cold is defined as $<0^{\circ}\text{C}$ (32°F) during storage and $<5^{\circ}\text{C}$ (41°F) during use.

Caution: Use ONLY the USB charging cable and adapter that you received in the box with your Controller. AVOID using alternative charging cables or other accessories, as they may damage the Controller or affect the way it charges in the future. If you must use a different cable, use only cables less than or equal to 1.2 m (4 ft) in length.

Caution: DO NOT place the Controller in or near water because the Controller is not waterproof. Failure to do so could result in damage to the Controller.

Caution: DO NOT use solvents to clean your Controller. DO NOT immerse your Controller in water as it is not waterproof. The use of solvents or immersion in water could result in damage to the Controller.

Caution: DO NOT allow debris or liquid to get into the USB port, speaker, sound/vibrate button or Power button while cleaning the Controller. Failure to do so could result in damage to the Controller.

Communication

Caution: When there is no communication between the Pod and the Controller, the Pod continues delivering insulin according to settings active on the Pod before losing communication. For example, Automated insulin delivery from the Pod will continue in Automated Mode. Restoring communication is needed to see your system status, notifications, and to send new instructions to the Pod. To restore communication, try bringing the Controller within 1.5 m (5 ft) of the Pod. See “26.5 Pod Communication Issues – “Try Again”” on page 374.

Caution: DO NOT use portable radio frequency (RF) communications equipment (including peripherals such as antenna cables and external antennas) closer than 30 cm (12 in) to any part of the Omnipod 5 System, as it may impact the communication between your Controller and your Pod.

Alarms and Sound

Caution: ALWAYS respond to Pod Expired, Low Pod Insulin, and Pod Shut-Off Advisory Alarms when they occur. These alarms escalate to Hazard Alarms if no action is taken. When Hazard Alarms occur, insulin delivery stops.

Caution: Permanently silencing a Pod alarm requires the Pod to be removed from your body. Once removed and discarded, promptly activate a new Pod to avoid going too long without insulin, which could lead to hyperglycaemia.

Caution: ALWAYS check the alarm function when you change the Pod if you suspect any issue with the Pod's sounds to ensure you don't miss important alarms during use (see “Check alarms” on page 157).

Caution: AVOID setting your Controller to Silent, Vibrate or any other setting that prevents you from hearing alarms and notifications from your Omnipod 5 App. If you do not hear alarms and notifications from your Controller, you might not make the changes you need to make to your insulin therapy in a timely manner. Your Pod will still sound, and you will be able to see the Alarm or Notification displayed on the Omnipod 5 App. See “13.3 Sounds and Vibrations” on page 153 to learn how to manage sounds and vibrations.

This page intentionally left blank.

CHAPTER 2

System Terminology and Navigation

Contents

- 2.1 Terminology 30**
- 2.2 Using the Touchscreen and Entering Information 33**
 - Touchscreen Basics 33
 - Tapping and swiping 33
 - Screen time-out and brightness 34
 - Entering Numbers and Text 34
 - Using a keypad 34
 - Using a number pad 34
 - Using a scroll wheel 35
 - Selecting, Adding and Deleting Items 35
 - Toggles 35
 - Add and delete buttons 35
 - Navigation Buttons and Navigation Shorthand 36
 - Options button 36
 - Technical User Guide navigation shorthand 36

2 System Terminology and Navigation

2.1 Terminology

Term	Description
Activation	The process of waking up a Pod and setting up exclusive communication with the Omnipod 5 App that woke it up.
Adaptive Basal Rate	Insulin delivery, in units per hour, that is calculated by SmartAdjust™ technology to aim your glucose towards your target. This amount changes over time based on your insulin delivery history.
Advisory Alarm	An alarm that alerts you to some aspect of the Omnipod 5 System that will need your attention in the near future, such as a low amount of insulin remaining in your Pod.
Automated Mode	An insulin delivery method that uses your insulin delivery history, sensor glucose value and trend to automatically increase, decrease and pause delivery of insulin based on current and predicted glucose values using a customisable glucose target, or Target Glucose.
Automated Mode: Limited	Automated insulin delivery used when sensor glucose values are not available. Insulin delivery is based on your settings and recent history.
Basal insulin	A small amount of insulin that is delivered throughout the day and night to help keep glucose stable.
Basal Programme	Insulin delivery schedule used to deliver insulin in Manual Mode. Also considered in some instances for Automated Mode
Basal rate	The number of units of insulin delivered in one hour (U/hr).
BG	Blood Glucose
Bolus insulin	A dose of insulin delivered for meals with carbohydrates and/or to correct a high glucose.
Cannula	A small, thin tube inserted under the skin that the Pod uses to deliver insulin.

Carbs (carbohydrates)	Sugars and starches that are consumed and that the body breaks down into glucose.
Connecting	In Omnipod 5, “connecting” refers to setting up wireless communication between system components. Omnipod 5 uses Bluetooth® wireless technology to communicate with your Pod and from the Sensor to the Pod.
Controller	Omnipod 5 device, supplied by Insulet, that contains the Omnipod 5 App for use to control the Omnipod 5 System.
Deactivate	Preferred method for shutting down the Pod. Deactivation turns off insulin delivery in the Pod and allows the Omnipod 5 App to activate a new Pod.
Device	In Omnipod 5, “device” refers to the Omnipod 5 Controller used to control the Omnipod 5 App.
Discard Pod	When a communication problem prevents you from deactivating a Pod, the DISCARD option allows Omnipod 5 to activate a new Pod without shutting down the active Pod. Always remove a “discarded” Pod from your body, as it may still be delivering insulin.
Hazard Alarm	An alarm that alerts you to a problem with the Omnipod 5 System that needs your immediate attention, such as a disruption to your insulin delivery.
Hyperglycaemia	High glucose. A higher-than-normal level of glucose in the blood; generally above 13.9 mmol/L (250 mg/dL).
Hypoglycaemia	Low glucose. A lower-than-normal level of glucose in the blood; generally below 3.9 mmol/L (70 mg/dL).
Hypoglycaemia unawareness	A condition in which a person does not feel or recognise the symptoms of hypoglycaemia.
Infusion site	The place on the body where a Pod’s cannula is inserted to deliver insulin.
Insulin on Board (IOB)	Insulin that is still active (available to lower glucose) in the body.

2 System Terminology and Navigation

Ketoacidosis (Diabetic ketoacidosis, or DKA)	Diabetic ketoacidosis (DKA) is a serious condition in which extremely high glucose and a severe lack of insulin cause the body to break down fat for energy. The breakdown of fat releases ketones into the blood and urine. DKA can take hours or days to develop, with symptoms that include stomach pain, nausea, vomiting, fruity breath odour and rapid breathing.
Ketones	Acidic by-products that result from the breakdown of fat for energy. The presence of ketones indicates that the body is using stored fat (instead of glucose) for energy.
Line of sight	How to wear the Pod and Sensor on the same side of the body in such a way that the two devices can “see” one another without your body blocking their communication.
Manual bolus	A bolus amount chosen by you (not calculated by the SmartBolus Calculator).
Manual Mode	Insulin delivery method that delivers insulin amounts according to the basal rates in your Basal Programme.
Microbolus	A small amount of insulin calculated by SmartAdjust technology, delivered automatically by the Pod every 5 minutes during Automated Mode.
Omnipod 5 Application (App)	Software on the Controller that is the primary user interface of the Omnipod 5 System.
Sensor	Component of a sensor glucose monitoring system that is inserted under the skin to measure glucose in interstitial fluid.
Sensor Glucose Monitoring System	System to track glucose throughout the day and night, supplied by a third-party medical device manufacturer. Also known as Continuous Glucose Monitor (CGM).
Sensor glucose value	Glucose measured by a Sensor. Sensor glucose values include trend, which indicates whether your glucose is going up, down, or remaining steady.

SmartAdjust™ technology	Pod software used to calculate automated insulin delivery, as often as every 5 minutes to bring your glucose to your customised glucose target, or Target Glucose.
Target Glucose	The user-customisable glucose target used by both SmartAdjust technology and the Omnipod 5 SmartBolus Calculator to calculate how much insulin you need based on both your manually entered blood glucose readings and the sensor glucose values from your Sensor. Target Glucose can be set from 6.1–8.3 mmol/L (110–150 mg/dL) in 0.55 mmol/L or (10 mg/dL increments).
Transmitter	Component of a sensor glucose monitoring system that sends sensor glucose values to the Pod.
Units	How insulin is measured.

2.2 Using the Touchscreen and Entering Information



This section explains how to use the touchscreen, how to enter numbers or text into the Omnipod 5 App, and how this *Technical User Guide* describes moving between Omnipod 5 App screens.

Touchscreen Basics

The Omnipod 5 App displays messages and options for you on its touchscreen.

Tapping and swiping

The basic instructions for interacting with the touchscreen are explained here.

	Tap	Touch the screen, then lift your finger up.
	Swipe	Touch a starting point and move your finger up, down, left or right. Note: Scrolling and swiping are related actions. When you swipe up, the screen display scrolls up to show items that are currently off-screen.

2 System Terminology and Navigation

Note: A screen protector may decrease the touchscreen sensitivity.

Screen time-out and brightness

The screen on the Controller turns black, called “timing-out”, after a period of inactivity. To control the screen time-out and brightness settings, see “Screen Display” on page 124. The screen dims 6–10 seconds before it times out. If the screen dims, tap the screen to prevent it from timing out.

Entering Numbers and Text

Tapping in an editable field can bring up a keypad or number pad.

Using a keypad



Using a number pad

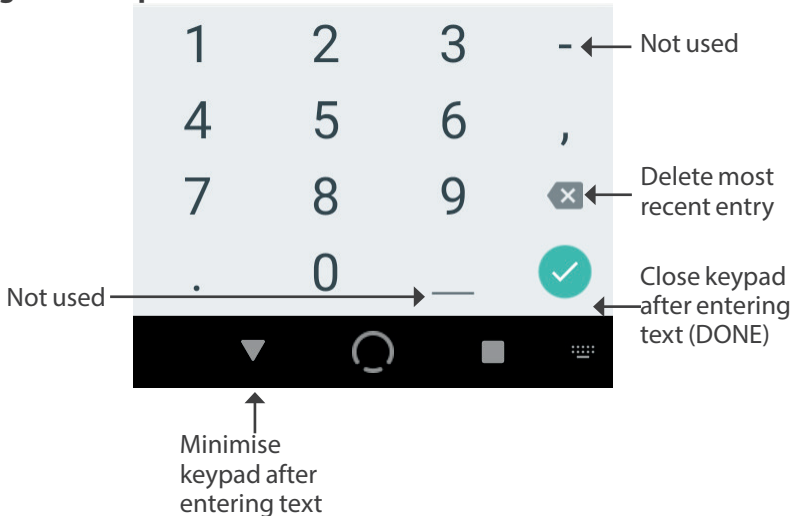

Using a scroll wheel

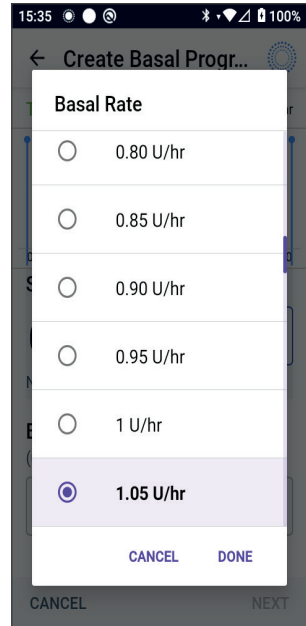

Tapping an editable field can bring up a scroll wheel. Place your finger on the scroll wheel. Swipe up or down to select your desired value. The faster you move your finger, the faster the wheel will scroll.

When your desired selection is shown, select the value by tapping the radio button next to the value and tapping DONE.





Selecting, Adding and Deleting Items

Toggles

-  Tap a toggle to change the selection from one side to the other.
-  Toggles allow you to turn a feature ON or OFF. The toggle is on the right side and purple when a feature is ON, and on the left and grey when a feature is OFF.

Add and delete buttons

-  A plus symbol in a circle indicates that you can add an item to a list. Tap the plus symbol to add the item to the list.
-  A red x in a circle indicates that you can remove an item from a list. To remove the item, tap the red x.

Navigation Buttons and Navigation Shorthand

Options button



The Options button (⋮) appears on the side of certain lists. Tapping the Options button brings up a list of options relevant to the item on that row.

Technical User Guide navigation shorthand

The *Technical User Guide* uses the “>” symbol to indicate navigating from one screen to another. For example:

- Menu button (≡) > Pod > CHANGE POD

tells you to:

1. Tap the Menu button (≡) in the upper left of the Home screen.
2. Tap Pod to open the Pod screen.
3. Tap CHANGE POD.

CHAPTER 3

Omnipod 5 System Overview

Contents

3.1 Omnipod 5 App and Sensor Communication	39
Omnipod 5 App and Dexcom G6 Communication	39
Omnipod 5 App and FreeStyle Libre 2 Plus Sensor Communication	40
3.2 Omnipod 5 App	41
The Omnipod 5 Controller	41
3.3 Lock Screen and Security.	42
Omnipod 5 App Security on Your Controller	42
Unlock your Controller	42
Lock your Controller	42
Forgot your PIN?	43
3.4 Status Bar.	44
3.5 Home Screen	45
DASHBOARD Tab	46
Without paired	
Dexcom G6 Transmitter or FreeStyle Libre 2 Plus Sensor	46
With paired Dexcom G6 Transmitter or FreeStyle Libre 2 Plus Sensor	47
INSULIN Tab	48
Manual Mode	48
Temp basal	49
Automated Mode	49
Activity feature	49
POD INFO Tab	50
POD INFO banners	51
Bolus Information and Button	52
Between boluses	52
During a bolus	52
Bolus information if there is no Pod communication	52
Estimated and unconfirmed bolus amounts	52
Bolus button	52
3.6 Home Screen Main Menu.	53

3 Omnipod 5 System Overview

About screen	54
3.7 Notifications and Messages	54
Omnipod 5 Notifications.....	54
Alarms	54
Action Item notifications.....	55
Reminder notifications.....	55
Status.....	55
Confirmation Messages.....	55
3.8 Manual and Automated Mode Overview	56
Available tasks in each mode	56
Identifying System modes	58

3.1 Omnipod 5 App and Sensor Communication

Communication between the parts of your Omnipod 5 System will be different depending on which Sensor you choose.

Omnipod 5 App and Dexcom G6 Communication

The Omnipod 5 System communicates with the Dexcom G6 Continuous Glucose Monitoring (CGM) System.

- The Pod delivers insulin to your body, receives commands from the Omnipod 5 App, receives sensor glucose values from the Dexcom Transmitter, sends sensor glucose values to the Omnipod 5 App and automatically adjusts insulin delivery in Automated Mode.
- Your Dexcom G6 Transmitter sends sensor glucose values to the Pod and to the Dexcom G6 App. The Omnipod 5 App does not communicate directly with the Dexcom G6 App. For Dexcom-specific information, refer to your *Dexcom G6 CGM System Instructions for Use*.
- The Controller lets you control the Pod using the Omnipod 5 App.



3 Omnipod 5 System Overview

Omnipod 5 App and FreeStyle Libre 2 Plus Sensor Communication

The Omnipod 5 System communicates with the FreeStyle Libre 2 Plus Sensor.

- The Pod delivers insulin to your body, receives commands from the Omnipod 5 App, receives sensor glucose values from the FreeStyle Libre 2 Plus Sensor, sends sensor glucose values to the Omnipod 5 App and automatically adjusts insulin delivery in Automated Mode.
- The FreeStyle Libre 2 Plus Sensor sends sensor glucose values to the Pod and to the Omnipod 5 App. For Sensor-specific information, refer to your FreeStyle Libre 2 Plus User's Manual.
- The Controller lets you control the Pod and Sensor using the Omnipod 5 App.
- The Omnipod 5 App activates the Pod, sends bolus commands to the Pod, receives insulin delivery and Sensor info from the Pod when the Pod is nearby, displays sensor glucose value & trend from the Pod, troubleshoots, adds a Sensor, and receives and displays information and alarms directly from the Sensor only when no Pod is active.

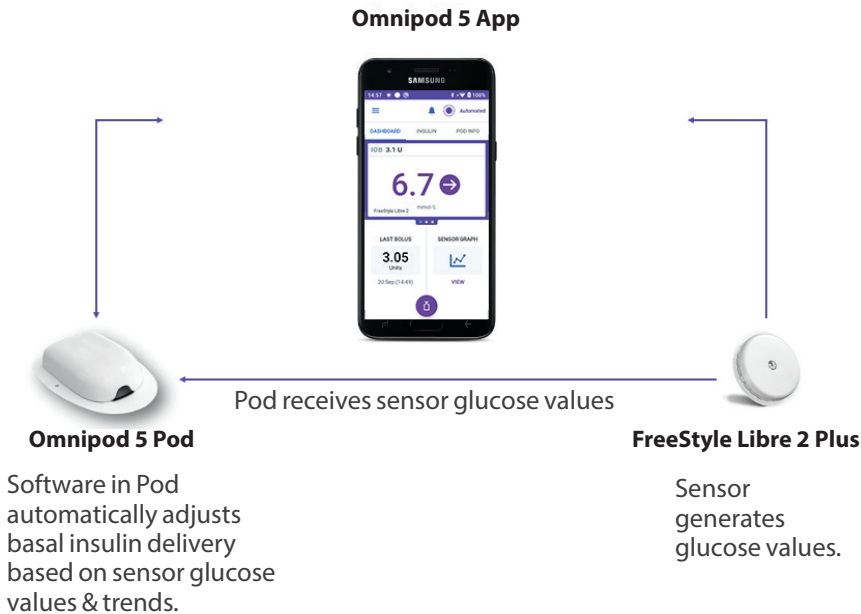

3.2 Omnipod 5 App

You use the Omnipod 5 App to control and monitor the Pod's operations using Bluetooth® wireless technology.

Caution: AVOID leaving your Controller in a place that would prevent you from hearing alarms and notifications from your Omnipod 5 App. Delivery of insulin in Manual Mode or Automated Mode continues as programmed if you move away from your Controller.

The Omnipod 5 Controller



3.3 Lock Screen and Security

Warning: ALWAYS identify the Omnipod 5 App as yours before using it. Using someone else's Omnipod 5 App can result in incorrect insulin delivery for both of you.

Warning: ALWAYS keep your Controller safe and within your control to ensure others cannot make changes to your insulin therapy. Unintended changes to your insulin delivery could result in over-delivery or under-delivery of insulin, which can lead to hypoglycaemia or hyperglycaemia. Be careful who you share your Controller PIN with.

Omnipod 5 App Security on Your Controller

After you set up your provided Controller, the Lock and PIN screens appear whenever you wake up your Controller.

The Lock screen displays:

- Your selected background image.
- Today's date and time.
- Your customised message.
- The current system mode.
- The amount of Insulin on Board.
- Any alarm or notification messages.

Unlock your Controller

In the remainder of this *Technical User Guide*, instructions to “wake up” or “unlock” the Controller mean to do the following:

1. Press and release the Power button.
2. Unlock the Lock screen by either swiping left to right or by swiping up from the bottom. The PIN screen appears.
3. Enter your 4-digit PIN.
4. Tap OK. The Home screen or your most recent screen appears.

Lock your Controller

To lock your Controller when you are finished using it:

- Press the Power button briefly. This locks the Controller by putting it to sleep.

Note: Keep your Controller in a safe, accessible location.

Caution: ONLY press the Power button on the Controller for less than 1 second or you may accidentally turn the power off. If the Controller displays a message asking if you would like to “Power Off”, tap outside the message to cancel the message. If you accidentally power off your Controller, you can miss important notifications and alarms from the Omnipod 5 App. If you do not hear alarms and notifications from your Controller, you might not make the changes you need to make to your insulin therapy in a timely manner. The Pod will sound regardless of whether the state of the Controller is On or Off.

Forgot your PIN?

If you have problems with your PIN, contact Customer Care. For contact information, see the Customer Care card at the front of this *Technical User Guide*.

3 Omnipod 5 System Overview

3.4 Status Bar

At the top of the screen is a status bar that shows icons for both the Omnipod 5 App and your Controller. The following icons will display when applicable:

- Omnipod 5 Status icon
- Battery level
- Battery charging indication
- Current time

Status bar icon definitions:

 Omnipod 5 status – Automated Mode

 Omnipod 5 status – Manual Mode

 Hazard Alarm

 Advisory Alarm

 Action Item notification

 Reminder

 Vibrate/Mute

 Flight mode ON

 Bluetooth wireless technology setting ON

 Mobile connectivity

 Wi-Fi

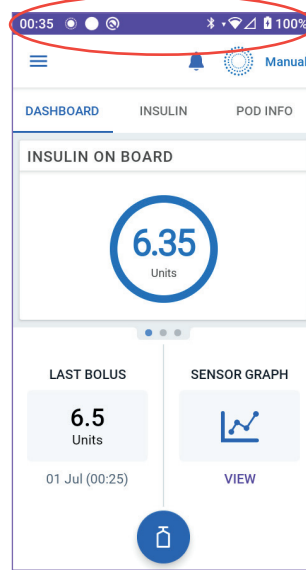

Note: Swipe down from the status bar for more details on what's currently displayed on the status bar. Then, swipe up to close.

Note: Device-specific icons such as Wi-Fi and vibrate/mute may vary in appearance.

3.5 Home Screen

This section introduces you to what you may see on the Omnipod 5 App Home screen. Different information will display depending on which system mode is activated.

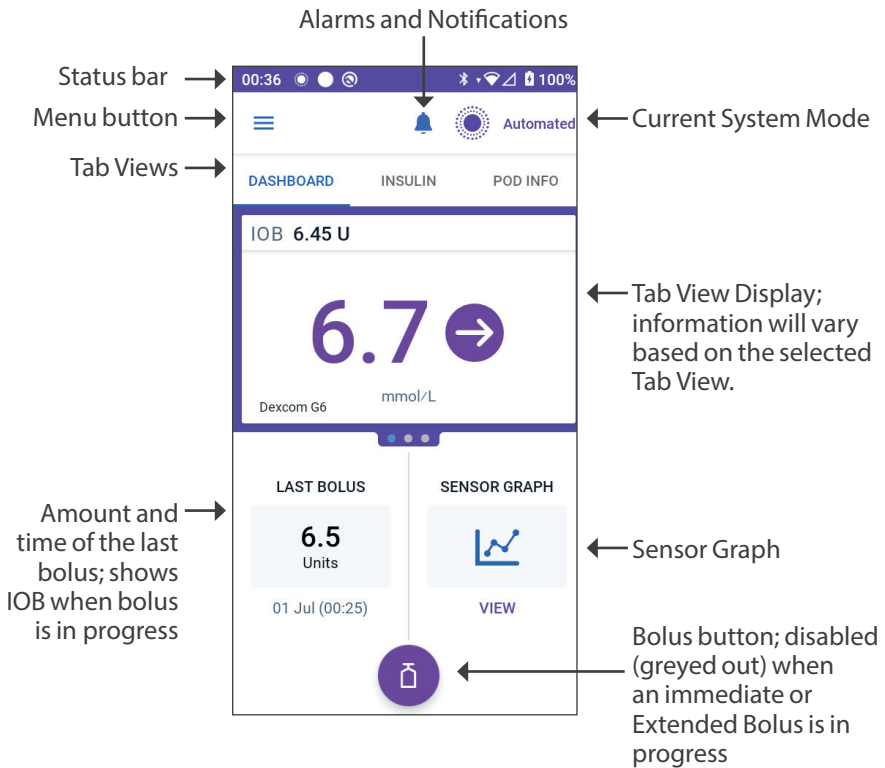

The Home screen tab view that you select determines what information displays on the screen. To change the information displayed:

- Tap DASHBOARD, INSULIN, or POD INFO.
- Swipe right or left in the middle portion of the screen (directly below the Home screen tabs) to move between tab views.
- If an immediate bolus is in progress, a bolus progress bar and a button to cancel the bolus are shown on the Home screen. The three tabs are not visible if an immediate bolus is running. (See “17.6 Delivering an Immediate Bolus” on page 224).

DASHBOARD Tab

The DASHBOARD tab displays the following information.

Note: The DASHBOARD tab shows different content if a Dexcom G6 Transmitter or FreeStyle Libre 2 Plus Sensor is paired to the Omnipod 5 App.

Without paired Dexcom G6 Transmitter or FreeStyle Libre 2 Plus Sensor

- INSULIN ON BOARD (IOB): value displays when IOB is available.
- INSULIN ON BOARD (IOB): displays as dashes when IOB is unavailable or there is no Pod communication. Tap MORE INFORMATION for possible reasons.

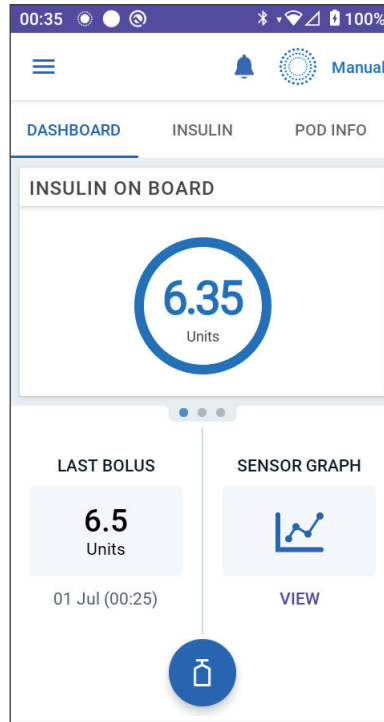

With paired Dexcom G6 Transmitter or FreeStyle Libre 2 Plus Sensor

- INSULIN ON BOARD (IOB).
- Sensor glucose value (with trend arrow): when a sensor glucose value is available.
- Sensor glucose value (without arrow): when Sensor supplies a sensor glucose value but is unable to report sensor glucose trend.
- HIGH: when the sensor glucose value received from your Sensor is greater than your Sensor's maximum display value:
 - Dexcom G6: 22.2 mmol/L (400 mg/dL).
 - FreeStyle Libre 2 Plus: 27.8 mmol/L (500 mg/dL).
- LOW: when the sensor glucose value received from your Sensor is less than 2.2 mmol/L (40 mg/dL).

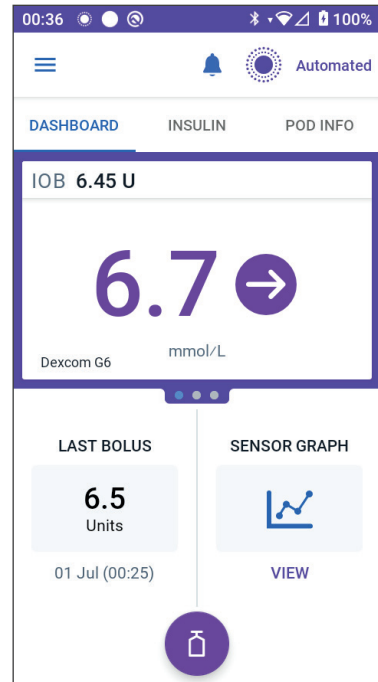

The DASHBOARD tab also displays information related to potential Sensor communication issues.

A progress bar appears when a bolus is in progress (see “16.3 Tracking the Progress of a Bolus” on page 214).

3 Omnipod 5 System Overview

INSULIN Tab

The INSULIN tab label changes to ACTIVITY when the Activity feature is enabled in Automated Mode or to TEMP ON when a Temp Basal is running in Manual Mode.

Manual Mode

By default, in Manual Mode, the INSULIN tab shows the name and graph of the user-defined Basal Programme. A label below the Basal Programme's name indicates whether the listed Basal Programme is:

- In progress—This programme is running on the active Pod.
- Paused—This programme will resume when you start insulin delivery.
- Current—There is no active Pod. This programme will be sent to your next Pod during activation.

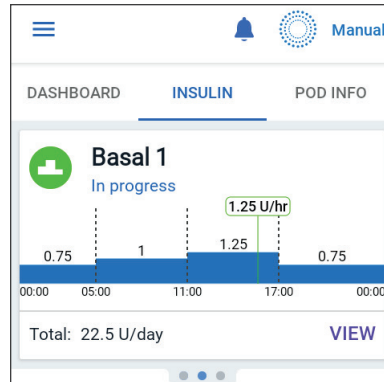

When there is a Basal Programme in progress, a green vertical line marks the current time. The numbers above the graph indicate the basal rate for each time segment.

The total daily amount of basal insulin in Manual Mode is shown beneath the graph. This total is the amount of insulin that the Basal Programme in progress is scheduled to deliver in a 24-hour period. This total does not account for Temp Basals or boluses.

To see the total amount of insulin that your Pod has actually delivered, including Temp Basals and boluses, see “Browsing Your History and Records” on page 131.

Tap VIEW to see details about other Basal Programmes.

Temp basal

When a Temp Basal is running, the INSULIN tab label changes to TEMP ON and is highlighted in light blue. It displays the Temp Basal graph and allows you to cancel the Temp Basal. See “7.1 About Temporary Basal Rates” on page 102.

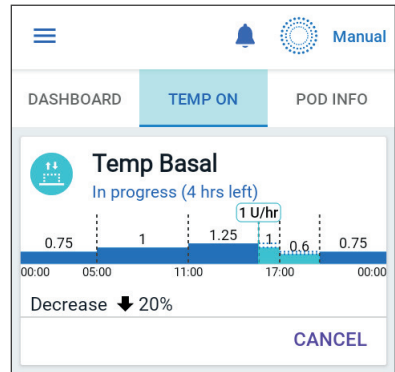

Automated Mode

In Automated Mode, the INSULIN tab shows AUTOMATED MODE: ACTIVE and displays LAST BOLUS and SENSOR INFO. For more information on using Automated Mode, see “About Automated Mode” on page 305.

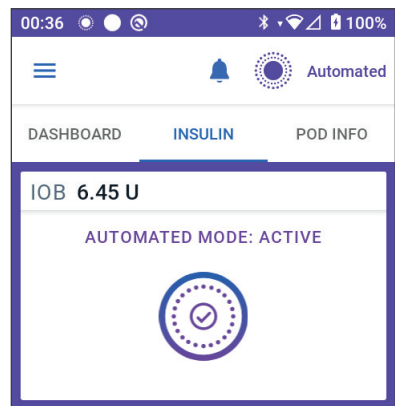

Activity feature

In Automated Mode, when the Activity feature is enabled, the INSULIN tab label changes to ACTIVITY, highlighted in green, and shows Activity is ON. See “23.1 About the Activity Feature” on page 322 for more information.

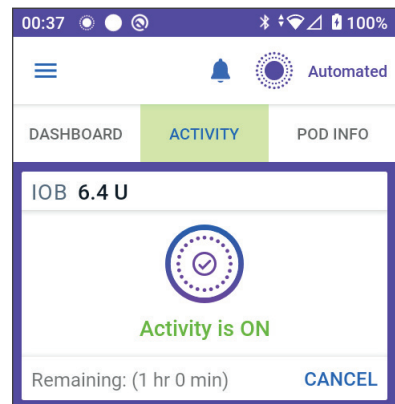

3 Omnipod 5 System Overview

POD INFO Tab

The POD INFO tab shows whether there is an active Pod, and, if so, how much insulin is left in the Pod and when the Pod will expire.

If the Omnipod 5 App cannot communicate with an active Pod, the POD INFO tab shows “No Pod Communication”. Tap MORE INFORMATION for details.

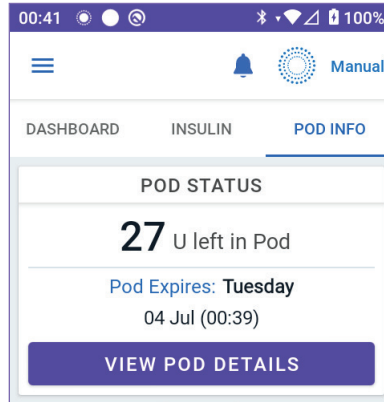

Caution: When there is no communication between the Pod and the Controller, the Pod continues delivering insulin according to the settings active on the Pod before losing communication. For example, Automated insulin delivery from the Pod will continue in Automated Mode. Restoring communication is needed to see your system status, notifications, and to send new instructions to the Pod. To restore communication, try bringing the Controller within 1.5 m (5 ft) of the Pod. See “26.5 Pod Communication Issues – “Try Again”” on page 374.

If there is no active Pod, the POD INFO tab shows “No Active Pod”. To set up a new Pod, see “Activating and Changing Your Pod” on page 77.

If there is an active Pod, tap VIEW POD DETAILS to bring up a screen that lets you deactivate or change your Pod.

The VIEW POD DETAILS screen shows:

- Amount of insulin in the Pod.
- Time of the last communication between the Omnipod 5 App and Pod.
- Date and time of the Pod’s expiry.
- Reminders.
- A CHANGE POD button.

Tip: You can also access this screen by tapping Menu button (☰) > Pod.

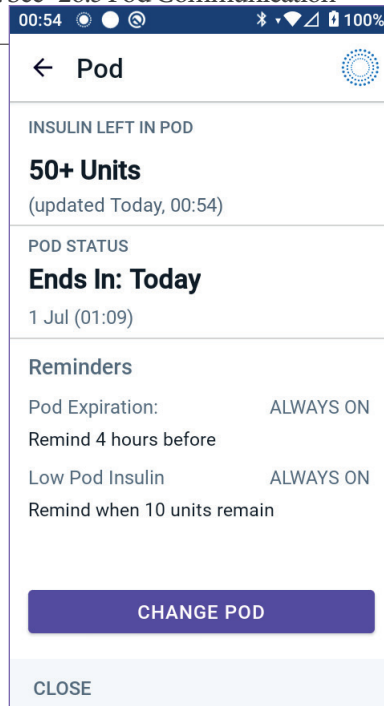

POD INFO banners

When your Pod will expire soon, a yellow CHANGE POD SOON banner appears on the POD INFO tab. The yellow banner appears 12 hours before Pod expiry or at the time of your Pod expiry Reminder, whichever is earlier.

CHANGE POD SOON

20 U left in Pod

Pod Expires: **Today**
01 Jul (10:18)

VIEW POD DETAILS

At 6 hours before Pod expiration, a red CHANGE POD banner appears on the POD INFO tab.

CHANGE POD

14 U left in Pod

Pod Expires: **Today**
01 Jul (00:57)

VIEW POD DETAILS

When less than 5 units of insulin remain in the Pod, a red LOW POD INSULIN banner appears on the POD INFO tab. If the Pod will expire soon **and** there are less than 5 units of insulin in the Pod, the red LOW POD INSULIN banner is displayed on the POD INFO tab.

! LOW POD INSULIN

Less than 5 Units

Pod Expires: **Today**
01 Jul (01:01)

VIEW POD DETAILS

Note: If you change the time zone, the Pod expiry time is adjusted to match the new time zone selection.

Bolus Information and Button

The lower left section of the Home screen displays bolus information. The Bolus button is at the bottom.

Between boluses

When a bolus is not being delivered, the section is labelled LAST BOLUS and shows the amount and time of the most recent bolus.

During a bolus

When a bolus is being delivered, the last bolus information is replaced by an estimate of the Insulin on Board (IOB):

- During an immediate bolus, the IOB estimate is updated every second.
- During an Extended Bolus, the IOB estimate is updated based on:
 - Previous boluses.
 - Amount of insulin already delivered from the ongoing bolus.
 - Amount of insulin projected to be delivered within the time period defined by your Duration of Insulin Action setting.

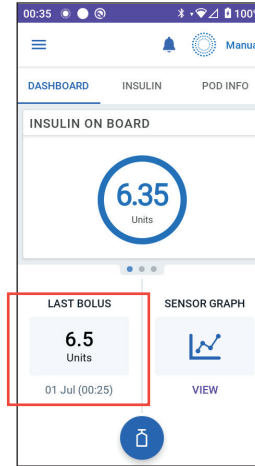

Bolus information if there is no Pod communication

If the Pod is out of range of the Controller and cannot confirm the recent bolus amount, an estimated bolus amount is shown. Once the Pod is in range again and the bolus delivery is confirmed, the confirmed bolus amount is shown.

Estimated and unconfirmed bolus amounts

The Omnipod 5 App estimates bolus amounts during an ongoing bolus and when the Pod is out of range. A grey icon (ⓘ) marks estimated bolus amounts. A yellow icon (⚠) marks unconfirmed bolus amounts (see “When the Pod has not confirmed a bolus delivery” on page 142).

Bolus button

The Bolus button provides access to the SmartBolus Calculator. The Bolus button is not available while an immediate or Extended Bolus is being delivered, or when there is no active Pod.



3.6 Home Screen Main Menu

The Main Menu on the Home screen lets you access most of the Omnipod 5 App's functions. To access the Main Menu:

- Tap the Menu button () in the upper left corner of the Home screen.
- or
- Place your finger on the far left side of the Omnipod 5 App and swipe right across the screen. Swipe left to hide the Menu.

Tap an option on the Menu to bring up the related screen.

Tip: The Menu extends beyond the bottom of the screen. Swipe up or down to see all parts of the Menu.

The menu options available to you vary according to the current mode: Manual or Automated. Menu options in grey are disabled based on current mode or settings.

The table below shows menu options and their availability in each mode:

Menu Options	Manual Mode	Automated Mode
Frequent Tasks		
Switch Mode	✓	✓
Set Temp Basal	✓	
Activity		✓
Pod	✓	✓
Manage Sensor	✓	✓
Enter BG	✓	✓
Pause Insulin	✓	
Manage Programmes & Presets		
Basal Programmes	✓	
Temp Basal Presets	✓	
History		
History Detail	✓	✓
Notifications	✓	✓
Settings		
General	✓	✓
Reminders	✓	✓
Glucose Goal Range	✓	✓

3 Omnipod 5 System Overview

Basal & Temp Basal	✓	
Bolus	✓	✓

About screen

The About screen displays details about your Omnipod 5 System, such as the Omnipod 5 App version number, the Customer Care contact information, the Controller serial number (if viewing on the Controller), the Pod version number, the time of the most recent Omnipod 5 App-Pod communication, and other Controller and legal information.

3.7 Notifications and Messages

Caution: AVOID setting your Controller to Silent, Vibrate or any other setting that prevents you from hearing alarms and notifications from your Omnipod 5 App. If you do not hear alarms and notifications from your Controller, you might not make the changes you need to make to your insulin therapy in a timely manner. Your Pod will still sound, and you will be able see the Alarm or Notification displayed on the Omnipod 5 App. See “13.3 Sounds and Vibrations” on page 153 to learn how to manage sounds and vibrations.

The Omnipod 5 App can deliver Omnipod 5 notifications and confirmation messages.

Omnipod 5 Notifications

Notifications display in order of importance and then based on the order they were received, with the most recent first. Hazard Alarms are most important, followed by Advisory Alarms, Action Item notifications, and lastly, Reminders.

Alarms

Alarms require your immediate attention (see page 156). If you ignore an alarm, you could develop hypoglycaemia or hyperglycaemia. When an alarm occurs, the Pod will beep and the Omnipod 5 App will beep or vibrate if sound/vibrate is on.

Hazard Alarms (▲) alert you to a problem with your insulin delivery, Pod, or Omnipod 5 App that requires immediate attention to resolve. Hazard Alarms are accompanied by a continuous tone from the Pod and tone/vibration from the Controller. Hazard Alarms interrupt anything else the

Omnipod 5 App is doing except another Hazard Alarm. For example, a Hazard Alarm is issued if the Pod runs out of insulin.

Advisory Alarms (⚠) alert you to some aspect of the Omnipod 5 App or Pod that will need your attention in the near future. For example, if the level of insulin in your Pod is getting low, the Omnipod 5 App issues an Advisory Alarm.

Action Item notifications

Action Item notifications (see page 171) are for technical System tasks that should be responded to as soon as possible. Action Item notifications are related to changes you may have made to your Omnipod 5 App that could affect safe use of the system. For example, a Turn on Bluetooth Action Item means Bluetooth wireless technology has been shut off and your App is no longer communicating with your Pod.

Reminder notifications

Reminder notifications (🕒) remind you about diabetes management actions you may want to perform (see “13.11 Reminder Notifications List” on page 181).

Status

Status notifications appear on the lock screen and display the current system mode and IOB, when available.

Confirmation Messages

In some situations, the Omnipod 5 App will display a green banner at the bottom of the screen that confirms the status of an action. The confirmation message disappears after several seconds.

Tip: Swipe to the right on the message to dismiss it sooner.

If an instruction is not successful, the Omnipod 5 App displays a communication error message (see “Frequently Asked Questions and Troubleshooting” on page 359).

3.8 Manual and Automated Mode Overview

Available tasks in each mode

The following table defines the tasks that can be performed in Manual Mode and Automated Mode.





	Manual Mode	Automated Mode
How it works		
Basal Insulin Delivery	Insulin is delivered according to the Active Basal Programme.	Insulin is delivered and adjusted automatically based on sensor glucose values and prediction.
Bolus Insulin Delivery	Insulin is delivered using the SmartBolus Calculator or entered manually.	Insulin is delivered using the SmartBolus Calculator or entered manually.
Connected Sensor	Not required. If connected, sensor glucose values displayed, stored in history, and available for use in SmartBolus Calculator.	Required. Sensor glucose values used for automated insulin delivery, displayed, stored in history, and available for use in SmartBolus Calculator.
What you can do		
Basal Programmes	Edit, create new, activate Basal Programmes (Does not impact Automated Mode).	Edit Target Glucose to impact Automated insulin delivery. Cannot modify Basal Programmes in Automated Mode.
Basal Insulin Delivery	Start and cancel Temp Basal Rate, create Temp Basal Presets.	Start and cancel the Activity feature.
SmartBolus Calculator Settings	Edit bolus settings.	Edit bolus settings.
Bolus Insulin Delivery	Deliver and cancel Immediate and Extended Boluses.	Deliver and cancel Immediate Boluses.

	Manual Mode	Automated Mode
What you can do		
Pod Changes	Activate and Deactivate Pods.	Deactivate Pods. Once deactivated, the system switches to Manual Mode. Pod activation occurs in Manual Mode (after activation, prompt to switch to Automated Mode is displayed.)
Manage Sensor	View and modify Dexcom G6 Transmitter serial number (SN). Switch between Sensor brands and models (between Pod changes). Start or delete a FreeStyle Libre 2 Plus Sensor; view wear duration, and configure alarm settings.	View Dexcom G6 Transmitter serial number (SN). View FreeStyle Libre 2 Plus Sensor wear duration and configure alarms.
Pause and Start Insulin	Manually pause insulin for a specified duration of up to 2 hours. Manually Start insulin.	System automatically pauses Automated insulin delivery based on sensor glucose value/prediction. Switch to Manual Mode to manually pause insulin delivery.
History Details	Review History Details.	Review History Details.
BG Entry	Enter blood glucose readings to save in History Details.	Enter blood glucose readings to save in History Details.
How you will be notified	See “Alarms, Action and Reminder Notifications” on page 149 for a detailed list of alarms and notifications.	

3 Omnipod 5 System Overview

Identifying System modes

The mode indicator shows the Omnipod 5 System's current operating mode.

Graphic	Description
	Displays when there is no Pod communication or no active Pod.
 Automated	Displays when the Omnipod 5 System is in Automated Mode and the Pod is providing Automated insulin delivery.
 Limited	Displays when the Omnipod 5 System is in Automated Mode: Limited state. The most common reason is that the Pod is not receiving sensor glucose values. In response, the system constantly compares its Automated Adaptive Basal Rate and your Manual Basal Programme and uses whichever rate is lower. Check your Sensor to make sure it is functioning. The position of the Pod and Sensor may also be contributing to the loss of connectivity between the devices.
 Manual	Displays when the Omnipod 5 System is in Manual Mode and delivering the active Basal Programme.

CHAPTER 4

Setting Up Your Omnipod 5 Application

Contents

4.1 Setting Up Your Account	60
4.2 Preparing for Your Training	60
Omnipod 5 Intro Kit contents	60
Items needed for your training	61
4.3 General Settings on Insulet-provided Controller	62
Turning On and Signing in to Your Controller	62
Setting Up Training	63
Setting Up Your Controller	64
Personalise your Controller	64
Setting the PIN on your Controller	64
Enabling Notifications and Sound on Your Controller	65
4.4 Basal Settings	66
Set Maximum Basal Rate	66
Create a Basal Programme	67
Name the Basal Programme	67
Define the segments	67
Review the Basal Programme	68
Temporary Basal Configuration	69
4.5 Bolus Settings	70
Target Glucose and Correct Above Values	70
Define the segments	70
Insulin-to-Carb (IC) Ratio	71
Define the segments	71
Correction Factor	72
Define the segments	72
Duration of Insulin Action	73
Maximum Bolus	74
Extended Bolus	74
4.6 Your App Setup is Complete	74
4.7 Saving Your Settings for Reference	75

4 Setting Up Your Omnipod 5 Application

Warning: DO NOT start to use your system or change your settings without adequate training and guidance from your healthcare provider. Initiating and adjusting settings incorrectly can result in over-delivery or under-delivery of insulin, which could lead to hypoglycaemia or hyperglycaemia. Settings that impact insulin delivery mainly include: Pod Shut-Off, basal rate(s), Max Basal Rate, Max Bolus, Correction Factor(s), Insulin-to-Carb (IC) Ratio(s), Minimum Glucose for Calculations, Target Glucose and Correct Above, and Duration of Insulin Action.

4.1 Setting Up Your Account

To use Omnipod 5, you need to sign in to Omnipod.com to complete onboarding. If you already have an Omnipod account, use the same Omnipod ID and password.

If you need to create an Omnipod ID:

1. Navigate to <https://Omnipod.com/setup>.
2. Follow the on-screen instructions to set up your account.

4.2 Preparing for Your Training

If you are a first-time Omnipod user, you may need to meet with your Omnipod 5 Trainer to set up your Omnipod 5 App, your first Pod and your Sensor. Your healthcare provider will help you coordinate and set up appropriate training.

To get a head start on learning about the Omnipod 5 System, review the *User Guide*.

Note: For training information about your Dexcom G6, refer to your *Dexcom G6 CGM System Instructions for Use*. For training information about your FreeStyle Libre 2 Plus, refer to your *FreeStyle Libre 2 Plus User's Manual*.

Omnipod 5 Intro Kit contents

Your initial shipment contains the items you need to begin using the Omnipod 5 System.

The Insulet-provided Omnipod 5 Intro Kit contains:

- Omnipod 5 Controller
- USB charging cable and adapter
- *User Guide*

After you unpack the shipment, use the “Contents” label on the side of the box to make sure you have everything.

The Dexcom G6 CGM System and supplies must be obtained from Dexcom or an authorised distributor. Refer to the *Dexcom G6 CGM System Instructions for Use*.

The FreeStyle Libre 2 Plus Flash Glucose Monitoring System and supplies must be obtained from Abbott Diabetes Care or an authorised distributor. Refer to the *FreeStyle Libre 2 Plus System User’s Manual* for instructions for use.

Items needed for your training

- Your Controller with Omnipod 5 App and charging cable and adapter
- Your glucose Sensor supplies
 - For Dexcom G6, your Dexcom G6 Sensor, Transmitter and Dexcom G6 App
 - For FreeStyle Libre 2 Plus, your FreeStyle Libre 2 Plus Sensor
- Two Pods
- The *Technical User Guide* and/or *User Guide*
- BG meter
- Test strips and a lancing device (available from many pharmacies)
- Vial of rapid-acting U-100 insulin (See page 7 for information about the approved types of insulin to use with the Pod).
- Alcohol prep swabs
- Instructions from your healthcare provider with Omnipod 5 App settings tailored to your needs. These settings include Basal Programme, Insulin-to-Carb Ratio, Correction Factor, Target Glucose and Duration of Insulin Action.

Note: Ensure that your Controller is charged before training begins. To charge your Controller, see “Charging the Battery” on page 189.

4 Setting Up Your Omnipod 5 Application

4.3 General Settings on Insulet-provided Controller

Warning: DO NOT start to use your system or change your settings without adequate training and guidance from your healthcare provider. Initiating and adjusting settings incorrectly can result in over-delivery or under-delivery of insulin, which could lead to hypoglycaemia or hyperglycaemia. Settings that impact insulin delivery mainly include: Pod Shut-Off, basal rate(s), Max Basal Rate, Max Bolus, Correction Factor(s), Insulin-to-Carb (IC) Ratio(s), Minimum Glucose for Calculations, Target Glucose and Correct Above, and Duration of Insulin Action.

Note: Tapping the back arrow on the screen returns you to the previous screen. However, tapping the CANCEL button in any of these set up steps takes you to the first screen of each section and erases any entries in that section. A pop-up screen warns you that you could lose these entries.

Turning On and Signing in to Your Controller

Caution: Connect ONLY to trusted Wi-Fi networks with your Controller. AVOID connecting to public Wi-Fi networks, such as those found in airports, coffee shops, etc., as these networks are not secure and could result in exposing your Controller to malware. DO NOT connect to public Wi-Fi networks during first-time setup of your Omnipod 5 System.

1. Press and hold the Power button on the right side until the device manufacturer logo appears.
2. Select your language.
3. The Controller runs through a series of checks. If prompted, allow permissions and connect to Wi-Fi. See page 171 for more details.

Note: The SIM Card on your Omnipod 5 Controller enables data to be sent and received via a mobile network when your Controller is not connected to a Wi-Fi network. If you stop using the Omnipod 5 App over a mobile network on your Controller, Insulet may deactivate the SIM Card. Please note that the Controller is still functional using Wi-Fi. If you return to using the Omnipod 5 App on your Controller after a significant period of time, please contact Customer Care to request SIM card reactivation for full coverage via both mobile network and Wi-Fi. Upon request, the SIM card is reactivated.

4. Sign in with your Omnipod ID:
 - a. Enter your username.
 - b. Enter your password.
 - c. Tap SIGN IN.

Tip: The username and password are case-sensitive.

Setting Up Training

After signing into the Controller, you will be prompted to schedule or confirm training for the Omnipod 5 System. Training is critical to the safe and effective use of the Omnipod 5 System.

1. Tap the checkbox if you understand and acknowledge the importance of completing training.
2. Tap CONTINUE.



DO NOT PROCEED

You must complete training before you can use this product!

The training includes:

- Set up and change your Pod
- Create and edit your Basal Programme
- Calculate your bolus
- Pause your insulin delivery
- Respond to your system alarms and notifications
- Set up Omnipod 5 App
- Connect your Sensor to the Omnipod 5 App

Adequate training is critical for the safe and effective use of this product. Improper set-up and/or use of the Omnipod 5 may cause under- or over-delivery of insulin, which may lead to hypo- or hyperglycaemia, and may put your health and safety at risk, and could lead to death.

I understand and acknowledge the terms above.

CONTINUE

4 Setting Up Your Omnipod 5 Application

Setting Up Your Controller

Warning: ALWAYS identify the Omnipod 5 App as yours before using it. Using someone else's Omnipod 5 App can result in incorrect insulin delivery for both of you.

Personalise your Controller

Follow the steps below to personalise your Controller.

1. Enter a personalised screen message (at least two characters), tap Done, then tap CONTINUE.

A screen appears showing several background images.

2. Swipe right or left to see more images. Tap on your preferred image, then tap CONTINUE.

Note: When you wake up your Controller, you will see your personalised screen message and background image. Always confirm that the Controller is yours before using it.

Setting the PIN on your Controller

To protect against unintended use or screen touches, you must create a 4-digit personal identification number or PIN.

To set a PIN:

1. Choose 4 numbers to be your PIN. You will use this PIN every time you wake up your Controller. You may want to record the PIN in a safe place.

Tip: To keep the PIN visible, tap the eye icon located to the right of the PIN entry fields. To hide the number, tap the eye icon again.

2. Tap a field to display the number pad. Enter your 4-digit PIN. Tap Done.
3. Enter the same 4 numbers again to confirm your PIN. Tap Done.

If the second PIN entry does not match the first, you must repeat the above steps.

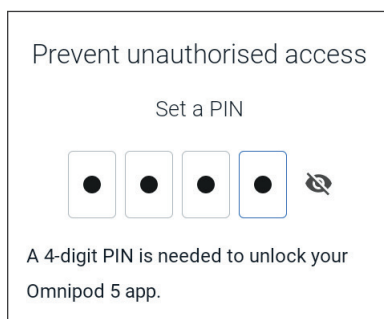

Enabling Notifications and Sound on Your Controller

1. Read the message explaining the importance of enabling Omnipod 5 App notifications. You cannot enter or use the App if you turn notifications off.
 - Tap I UNDERSTAND.
2. Read the message explaining the importance of enabling sound on your Omnipod 5 App. If you do not have sound enabled, you may miss important messages.
 - Tap I UNDERSTAND.

If you do silence your device, the Omnipod 5 App will still be able to sound for important alerts and alarms, such as Urgent Low glucose. Your Pod will not be silenced.

Notifications

To use the Omnipod 5 app, keep Notifications on. Notifications alert you when an issue requires your attention. You cannot use the app if you turn off Notifications.

I UNDERSTAND

Sound

Avoid setting your controller or smartphone to Silent, Vibrate or any other setting that prevents you from hearing alarms or notifications from your Omnipod 5 App.

The Pod will still sound, and you will be able to see the alarm or notification in the App.

I UNDERSTAND

4.4 Basal Settings

Warning: DO NOT start to use your system or change your settings without adequate training and guidance from your healthcare provider. Initiating and adjusting settings incorrectly can result in over-delivery or under-delivery of insulin, which could lead to hypoglycaemia or hyperglycaemia. Settings that impact insulin delivery mainly include: Pod Shut-Off, basal rate(s), Max Basal Rate, Max Bolus, Correction Factor(s), Insulin-to-Carb (IC) Ratio(s), Minimum Glucose for Calculations, Target Glucose and Correct Above, and Duration of Insulin Action.

Next, you will set basal settings, which will be used to deliver basal insulin while in Manual Mode.

1. Tap SET UP PROFILE.
2. Tap the arrow (>) on the Basal screen to move to the next screen.

Set Maximum Basal Rate

The Maximum Basal Rate sets the upper limit of any basal insulin rate you can use while in Manual Mode.

1. Tap the Max Basal Rate field.
2. Scroll to your desired Maximum Basal Rate. When the correct number is in the centre of the scroll wheel, tap the number to select it.

Tip: Alternatively, tapping outside of the scroll wheel selects the value in the centre of the scroll wheel.

3. Tap NEXT.

Note: You can adjust your Maximum Basal Rate later, if your needs change. See “Maximum Basal Rate” on page 130.

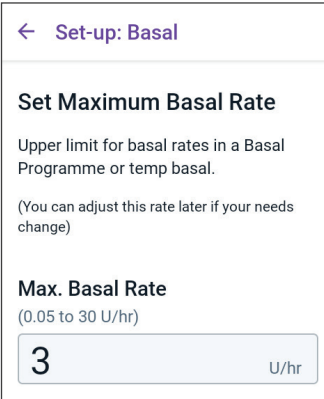

← Set-up: Basal

Set Maximum Basal Rate

Upper limit for basal rates in a Basal Programme or temp basal.

(You can adjust this rate later if your needs change)

Max. Basal Rate
(0.05 to 30 U/hr)

3 U/hr

Create a Basal Programme

The next step is to create a Basal Programme. For a description of basal rates, basal segments and Basal Programmes, see “Basal Programmes” on page 95.

- Tap NEXT on the Create Basal Programme description screen to continue.

Name the Basal Programme

The default name for the Basal Programme is Basal 1.

1. To change the name, tap the Programme Name field and enter the new name, then tap Done.
2. Tap NEXT.

← Set-up: Basal

Programme Name

Basal 1

Define the segments

You can create up to 24 segments within your midnight-to-midnight Basal Programme. The Start Time for the first segment is always 12:00.

1. Tap the End Time field and scroll to select the desired end time.
2. Tap the Basal Rate field and scroll to select the basal rate for the segment.

Note: The Maximum Basal Rate that you entered earlier is displayed under the Basal Rate text. You cannot enter a basal rate greater than this number.

Note: The two vertical blue lines on the graph near the top of the screen show the start and end time for the basal segment. The selected basal rate for the segment is shown between the two vertical lines.

3. Check the values of your start and end times and the basal rate. Then tap NEXT.
4. If the Basal Programme does not cover 00:00 to 00:00, you must add additional segments. Repeat steps 1–3 as needed until your final segment ends at midnight.

← Set-up: Basal

Basal 1 : Segment 1 Graph: U/hr

00:00 00:00

Start **End**

00:00 - ---

Night

Basal Rate
(up to 3 U/hr)

--- U/hr

CANCEL NEXT

4 Setting Up Your Omnipod 5 Application

Review the Basal Programme

The next screen summarises the start and end times, and basal rate for each segment of the Basal Programme.

1. Tap CONTINUE to review your Basal Programme.
2. Check that the graph and the individual segment values are correct.

The total daily amount of basal insulin to be delivered by this Basal Programme is listed below the graph.

3. To change an end time or basal rate for a segment:
 - a. Tap the row containing the segment you would like to change.
 - b. Tap the End Time field and enter the new end time for the segment.
 - c. Tap the Basal Rate field and enter the desired basal rate.
 - d. Tap NEXT.
 - e. Set the end time and basal rate for any following segments, as needed.

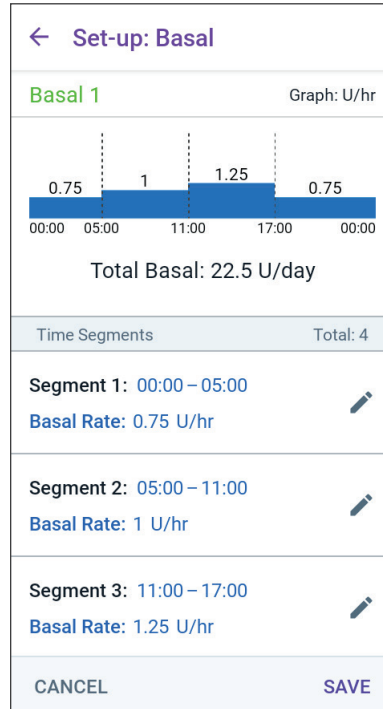

4. When the Basal Programme is correct, tap SAVE.
5. To add a new segment:
 - a. Tap the row containing the start time of the new segment.
 - b. Tap the End Time field and enter the start time of the new segment as the end time of this segment.
 - c. Change the basal rate, if necessary.
 - d. Tap NEXT.
 - e. Set the end time and basal rate for any following segments, as needed.
6. To delete a segment:
 - a. Note the end time of the segment you want to delete.
 - b. Tap the segment before the segment you want to delete.
 - c. Tap the End Time field and enter the end time of the segment you want to delete. This 'overwrites' the segment you want to delete.

- d. Tap NEXT.
- e. Set the end time and basal rate for any following segments, as needed.

7. When the Basal Programme is correct, tap SAVE.

Note: If the basal rate for a segment is 0 U/hr, the Omnipod 5 App displays a message calling this to your attention. Tap OK if the 0 U/hr rate is correct. Otherwise, tap CANCEL and edit the segment with the 0 U/hr rate.

Note: To create additional Basal Programmes after setup is complete, start at page 97 and begin steps again.

Temporary Basal Configuration

For a description of temporary basal rates, also called Temp Basals, see page 101.

Note: Temp Basal is available in Manual Mode only.

1. If you want the ability to use Temp Basals, tap the toggle to the ON position. The toggle is in the ON position when it is on the right and is purple.

If you turn Temp Basals on, percentages are used by default. To specify Temp Basal as a flat rate (U/hr), see “Temp Basal” on page 130.

2. Tap NEXT.

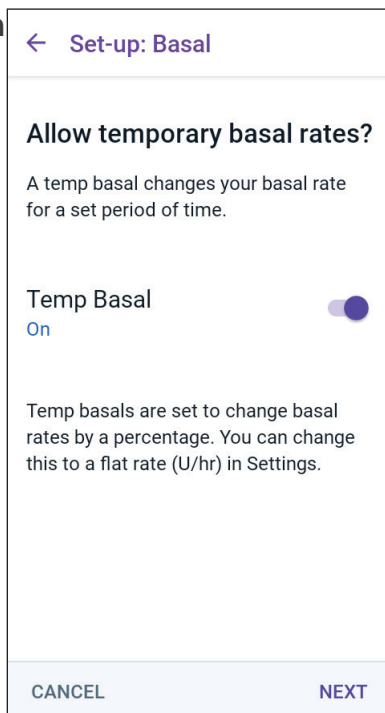

4 Setting Up Your Omnipod 5 Application

4.5 Bolus Settings

Next, you will set bolus settings that will be used to calculate a bolus in the SmartBolus Calculator. You can adjust your bolus settings later, if your needs change (see “17.8 Bolus Settings” on page 227 for more information).

1. Tap the arrow (>) on the Bolus screen to move to the Target Glucose & Correct Above description screen.
2. Tap NEXT to move to the segment screen.

Target Glucose and Correct Above Values

Target Glucose and Correct Above values are used in both Automated and Manual Modes.

- In Automated Mode, your insulin delivery will be adjusted automatically to bring your glucose towards your Target Glucose value.
- In both Automated and Manual Modes, the SmartBolus Calculator aims to bring your glucose to the Target Glucose value. The SmartBolus Calculator delivers a correction bolus if the current glucose value is higher than the Correct Above value.

Define the segments

You can establish up to eight different blood glucose targets for different times of day. To set Target Glucose and Correct Above values for each segment:

1. Tap the End Time field and specify an end time for the segment.
2. Tap the Target Glucose field and specify the Target Glucose for that segment.
3. Tap the Correct Above field and specify the Correct Above value for that segment.
4. Review and tap NEXT.
5. Repeat the above steps as needed until you have specified values for the segment that ends at midnight.
6. Review the segments for the full 24-hour profile.

The screenshot shows the 'Set-up: Bolus' screen. At the top, there is a back arrow and the title 'Set-up: Bolus'. Below this, 'Segment 1' is displayed in green. The 'Start' and 'End' time fields are set to '00:00' and '09:00' respectively, with 'Night' and 'Morning' labels below them. The 'Target Glucose' field is set to '6.1 mmol/L' with a range '(6.1 to 8.3 mmol/L)' below it. The 'Correct Above' field is set to '6.7 mmol/L' with a range '(Target Glucose to 11.1 mmol/L)' below it. At the bottom, there are 'CANCEL' and 'NEXT' buttons.

7. To change any of the entries:
 - a. Tap the row containing the entry to be changed and enter the corrected value.
 - b. Review and correct as needed any remaining segments.
8. When the segments and values are correct, tap **SAVE**.

← Set-up: Bolus

Review the Target Glucose and Correct Above values entered for each time segment.

Time Segments	Total: 3
Segment 1: 00:00 – 09:00	
Target Glucose: 6.1 mmol/L	
Correct Above: 6.7 mmol/L	
Segment 2: 09:00 – 12:00	
Target Glucose: 6.7 mmol/L	
Correct Above: 6.7 mmol/L	
Segment 3: 12:00 – 00:00	
CANCEL	SAVE

Insulin-to-Carb (IC) Ratio

Your Insulin-to-Carbohydrate Ratio, or “IC Ratio”, defines how many carbohydrates are covered by one unit of insulin.

The SmartBolus Calculator uses the IC Ratio to calculate the meal portion of a suggested bolus. You can create up to eight IC Ratio segments per day.

- Tap **NEXT** on the Set Insulin-to-Carb (IC) Ratio description screen to move to the Insulin-to-Carb Ratio segment screen.

Define the segments

1. Tap the End Time field and specify an end time for the segment.
2. Tap the 1 Unit of insulin covers field and specify the IC Ratio value for the segment.
3. Tap **DONE** to close the number pad.
4. Review and tap **NEXT**.

← Set-up: Bolus

Segment 1

Start	End
00:00	- <input style="width: 80px;" type="text"/>
Night	
1 Unit of insulin covers (1 to 150 g carbs)	
<input style="width: 100%; height: 30px;" type="text"/> g	

4 Setting Up Your Omnipod 5 Application

- Repeat the above steps as needed until you have specified values for the segment that ends at midnight.
- Review your 24-hour IC Ratio segments.
- To change any of the entries:
 - Tap the row containing the entry to be changed and enter the corrected value.
 - Review and correct as needed any remaining segments.
- When the segments and values are correct, tap **SAVE**.

← **Set-up: Bolus**

Review the Insulin to Carb (IC) Ratio values entered for each time segment.

Time Segments	Total: 4
Segment 1: 00:00 – 06:00	
1 U of insulin covers: 10 g of carbs	
Segment 2: 06:00 – 11:00	
1 U of insulin covers: 8 g of carbs	
Segment 3: 11:00 – 17:00	
1 U of insulin covers: 9 g of carbs	
Segment 4: 17:00 – 00:00	

CANCEL **SAVE**

Correction Factor

Your Correction Factor defines how much one unit of insulin lowers your glucose. For example, if your Correction Factor is 2.8 (50), one unit of insulin lowers your glucose by 2.8 mmol/L (50 mg/dL).

The SmartBolus Calculator uses the Correction Factor to calculate the correction portion of a suggested bolus. You can create up to eight Correction Factor segments per day.

- Tap **NEXT** on the Set Correction Factors description screen to move to the segment screen.

Define the segments

- Tap the End Time field and specify an end time for the segment.
- Tap the 1 Unit of insulin lowers glucose by field and specify the Correction Factor for this segment.
- Review and tap **NEXT**.
- Repeat the above steps as needed until you have specified values for the segment that ends at midnight.

← **Set-up: Bolus**

Segment 1

Start **End**

00:00 -

Night

1 Unit of insulin lowers glucose by
(0.1 to 22.2 mmol/L)

mmol/L

5. Review the segments for the full 24-hour profile.
6. To change any of the entries:
 - a. Tap the row containing the entry to be changed and enter the corrected value.
 - b. Review and correct as needed any remaining segments.
7. When the segments and values are correct, tap **SAVE**.

← Set-up: Bolus

Review the Correction Factor values entered for each time segment.

Time Segments	Total: 1
Segment 1: 00:00 – 00:00	
1 U of insulin lowers glucose by:	
2.8 mmol/L	

CANCEL
SAVE

Duration of Insulin Action

The Duration of Insulin Action is the length of time that insulin stays active in your body. The SmartBolus Calculator uses this setting to determine how much insulin remains in your body from previous boluses (called Insulin on Board or IOB).

1. Tap the Duration of Insulin Action field and scroll to select your Duration of Insulin Action.
2. Tap **NEXT**.

← Set-up: Bolus

Set Duration of Insulin Action

The length of time that insulin remains active and available in your body after a correction or meal bolus.

Duration of Insulin Action
(2 to 6 hrs)

hrs

CANCEL
NEXT

4 Setting Up Your Omnipod 5 Application

Maximum Bolus

The Omnipod 5 App will not let you request a bolus above the Maximum Bolus setting. You will see a message if the SmartBolus Calculator calculates a bolus that is above this amount.

1. Tap the Max Bolus field and enter your Maximum Bolus. Tap DONE to close the number pad.
2. Tap NEXT.

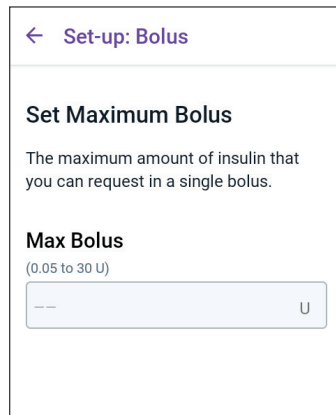

Extended Bolus

Extending a bolus allows you to give a portion of the bolus dose at the beginning of the meal with the remainder of the bolus dose dripped over a chosen period of time.

Note: Extended Bolus is available in Manual Mode only.

1. Toggle the Extended Bolus button to turn the Extended Bolus feature ON or OFF.
2. Tap NEXT.

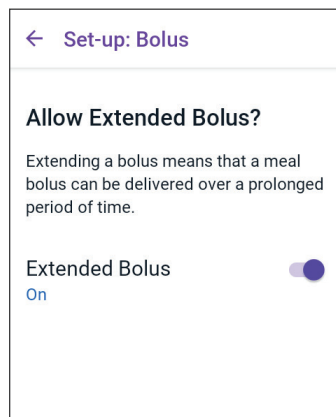

4.6 Your App Setup is Complete

Congratulations! Omnipod 5 App setup is complete.

When you are ready to activate your first Pod, go to “5.1 Beginning the Pod Activation Process” on page 78.

After successfully activating the Pod, you will be prompted to connect your Sensor to the Omnipod 5 System. See Chapters 19 and 20 for instructions on connecting your Sensor to the System.

4.7 Saving Your Settings for Reference

Caution: DO NOT reset the Omnipod 5 App before checking with your healthcare provider. This will erase all of your settings, Adaptive Basal Rate and history, and require you to change your active Pod. Before resetting, make sure you have a current record of your settings and a new Pod with supplies to use when restarting the App.

Before you begin using your Omnipod 5 App, write down or take photos of all your settings and keep them in a secure location that you can reference in the future. This list will be helpful if you ever need to go through the setup process again and re-enter your insulin therapy settings.

You will lose all your insulin therapy settings and insulin history if you do any of the actions listed below:

- Get a new Controller
- Reset your Controller

Tip: Use the pages at the end of this *Technical User Guide* to write down all of your settings. This list will be helpful if you ever need to replace your Controller or reset the Omnipod 5 App.

This page intentionally left blank.

CHAPTER 5

Activating and Changing Your Pod

Contents

5.1 Beginning the Pod Activation Process.....	78
5.2 Setting Up a New Pod.....	80
5.3 Fill the Syringe with Insulin	80
5.4 Filling, Activating, Applying and Starting the Pod	81
Fill the Pod with Insulin.....	82
Activate the Pod.....	82
Prepare the Pod Site.....	84
Guidelines for Pod site selection	84
Pod site examples	85
Pod site map (optional)	85
Prepare the infusion site	86
Remove the Pod's Tab.....	87
Apply the Pod	88
Begin Insulin Delivery	89
Confirm Pod is securely attached.....	89
5.5 Checking Your Infusion Site	89
5.6 Switching to Automated Mode	90
5.7 Deactivating an Active Pod.....	91
5.8 More Information about Pod Use	92
Avoiding Infusion Site Infections.....	92
Additional Information.....	93

5.1 Beginning the Pod Activation Process

Warning: DO NOT wear a Pod if you are sensitive to or have allergies to acrylic adhesives, or have fragile or easily damaged skin. Applying a Pod under these circumstances could put your health at risk.

Warning: ALWAYS be prepared to inject insulin with an alternative method if insulin delivery from the Pod is interrupted. You are at increased risk for developing hyperglycaemia if insulin delivery is interrupted because the Pod only uses rapid-acting U-100 insulin. Failure to have an alternative method of insulin delivery can lead to very high glucose or diabetic ketoacidosis (DKA). Ask your healthcare provider for instructions on handling interrupted insulin delivery.

Warning: DO NOT allow small children access to small parts, such as the Pod and its accessories, including the tab. Small parts could be swallowed and pose a choking hazard. If ingested or swallowed, these small parts could cause internal injury or infection.

Warning: NEVER use insulin that is expired or cloudy in the Pod as it may be damaged. Using damaged or expired insulin could cause hyperglycaemia and put your health at risk.

Caution: ALWAYS follow these steps in preparing your site. If your site is not cleaned properly or if your hands are dirty, you increase your risk of infection.

- Wash your hands.
- Clean the top of the insulin vial with an alcohol prep swab.
- Clean your infusion site with soap and water or an alcohol prep swab, and let it dry completely.
- Keep sterile materials away from any possible contamination.

Caution: DO NOT use a Pod if the sterile packaging is open or damaged, the Pod has been dropped after removal from the package or the Pod is expired, as the Pod may not work properly and increase your risk of infection.

Caution: DO NOT use any component of the Omnipod 5 System (Controller, Pod) if you suspect damage after an unexpected event such as dropping or hitting on a hard surface. Using damaged components may put your health at risk as the system may not be working properly. If you are unsure if one or more of your components are damaged, stop using the system and contact Customer Care for support.

Caution: ALWAYS rotate insulin infusion sites to help prevent infusion site complications like scar tissue and infection. Rotating insulin infusion sites reduces the risk of scarring. Using a site with scar tissue can lead to problems with insulin absorption.

After initial Omnipod 5 App setup, you will activate your first Pod. Your Pod should be changed at least once every 48 to 72 hours (2 to 3 days) or after depleting the insulin in the Pod. Consult with your healthcare provider to determine if you should change your Pod more often.

Before activating a Pod, do the following:

1. Gather the necessary supplies:
 - A vial of rapid-acting U-100 insulin cleared for use in the Omnipod 5 System. See “1.4 Compatible Insulins” on page 7 for a list of the approved insulin types that can be used with the Omnipod 5 System.
 - An unopened Omnipod 5 Pod.
 - Alcohol prep swabs.
 - Controller with Omnipod 5 App.
2. Wash your hands before starting and keep them clean throughout the Pod change process.
3. Check the insulin for signs of deterioration according to the manufacturer’s instructions for use.
4. Check the Pod’s packaging for damage. If undamaged, open it and inspect the Pod for signs of damage.
5. If the insulin or Pod is below 10°C (50°F), allow it to warm up to room temperature before proceeding.

Confirm that you are using an Omnipod 5 Pod prior to beginning Pod activation. Look for the Omnipod 5 logo on the Pod tray lid and the words “Omnipod 5” on your Pod. Check the Pod tray lid and Pod box for compatibility with the Sensor you will use with Omnipod 5.

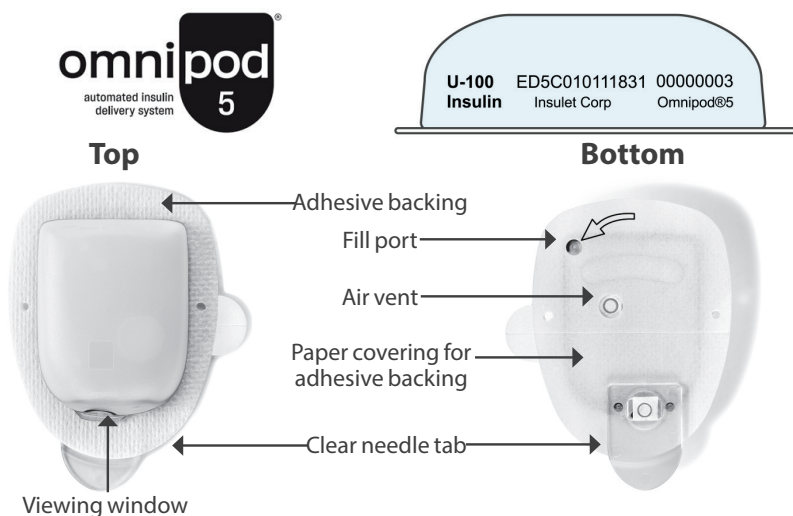

5.2 Setting Up a New Pod

1. Navigate to: Menu button (☰) > Pod
or
Home > POD INFO.
2. Tap SET UP NEW POD.

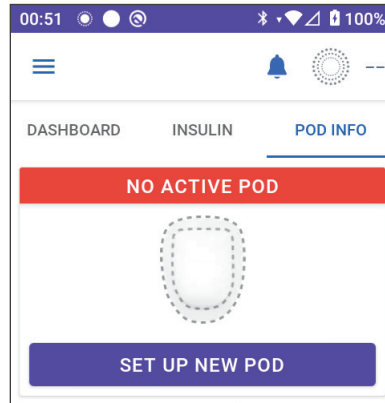

5.3 Fill the Syringe with Insulin

Warning: NEVER inject large bubbles or pockets of air when filling the Pod with insulin. Air in the system takes up space where insulin should be and can affect insulin delivery. Doing so could result in over-delivery or under-delivery of insulin, which can lead to hypoglycaemia or hyperglycaemia.

The next step is to fill the syringe that came with the Pod (the “fill syringe”) with insulin:

1. Use an alcohol prep swab to clean the top of the insulin vial.
2. Securely twist the fill needle onto the fill syringe.
3. Pull outwards to remove the protective cap from the needle.
4. Determine how much insulin you will put into the Pod. For example, to use the Pod for 72 hours, determine how much insulin you will use over the next 72 hours. Your healthcare provider can help you determine the correct amount.

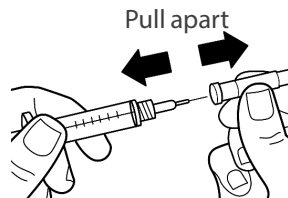
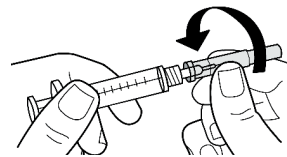

Note: The Pod requires a minimum of 85 units of U-100 insulin to begin operation. The Pod can deliver up to 200 units of U-100 insulin.

5. Draw air into the fill syringe up to the amount of insulin you want.
6. Insert the needle into the insulin vial and inject the air. Injecting air makes it easier to withdraw insulin from the vial.

7. Turn the vial of U-100 insulin and the fill syringe upside down. Pull down on the plunger to withdraw the desired amount of insulin from the vial into the fill syringe.
 - Fill the syringe at least to the MIN (minimum) fill line.
 - To fill the Pod with enough insulin to deliver 200 units, pull the plunger down until it stops. This will be below the 200 mark.
8. With the needle still in the vial, flick the side of the syringe with your fingertip to dislodge any air bubbles so they collect at the top of the syringe. Then push in the plunger to expel any air bubbles out of the syringe and into the insulin vial. Pull down on the plunger again, if necessary, to refill the fill syringe to the desired amount of insulin.
9. Remove the needle from the vial.

5.4 Filling, Activating, Applying and Starting the Pod

Warning: NEVER use a Pod if, while you are filling the Pod, you feel significant resistance while pressing the plunger down on the fill syringe. Do not try to force the insulin into the Pod. Significant resistance may indicate that the Pod has a mechanical defect. Using this Pod could result in under-delivery of insulin, which can lead to hyperglycaemia.

Warning: NEVER inject large bubbles or pockets of air when filling the Pod with insulin. Air in the system takes up space where insulin should be and can affect insulin delivery. Doing so could result in over-delivery or under-delivery of insulin, which can lead to hypoglycaemia or hyperglycaemia.

Caution: ALWAYS insert the fill syringe into the fill port and not into any other location on the Pod. Do not insert the fill syringe more than once into the fill port. Use only the fill syringe and needle that came with your Pod. The fill syringe is intended for single use only and should only be used with the Omnipod 5 System. Failure to follow the instructions above may result in damage to your Pod.

Fill the Pod with Insulin

To fill the Pod with insulin (screen step

1)

1. Locate the arrow on the underside of the Pod. The arrow points to the insulin fill port.

Tip: You can leave the Pod in its tray during filling and activating.

2. Insert the fill syringe straight down – not at an angle – into the fill port.
3. Depress the fill syringe plunger to transfer the insulin into the Pod.

Listen for two beeps from the Pod during the filling process (screen step

2):

4. Be sure to completely empty the fill syringe, even after hearing the two beeps.

Note: The Pod must contain a minimum of 85 units of insulin to function. The Pod beeps twice after it has been filled with 85 units of insulin. If you filled the Pod with more than 85 units and still do not hear the two beeps, contact Customer Care.

Note: After filling the Pod, continue to the next step immediately. If two hours pass before activating the filled Pod, the Pod becomes unusable.

5. Remove the needle from the insulin fill port. The port is self-sealing; insulin will not leak after the needle is removed.
6. Discard the fill needle in a sharps container.

Activate the Pod

To activate the Pod:

1. Place the Controller next to the Pod so they are touching. The Pod should be in its plastic tray during this process.

Note: ALWAYS ensure that no other Pods are being activated within 6 m (20 ft) of your Omnipod 5 App before filling a Pod. If the App detects more than one Pod, you will not be able to proceed.

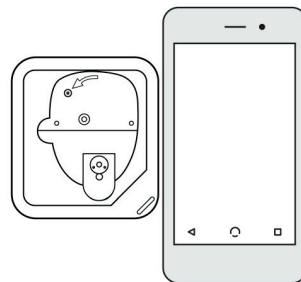
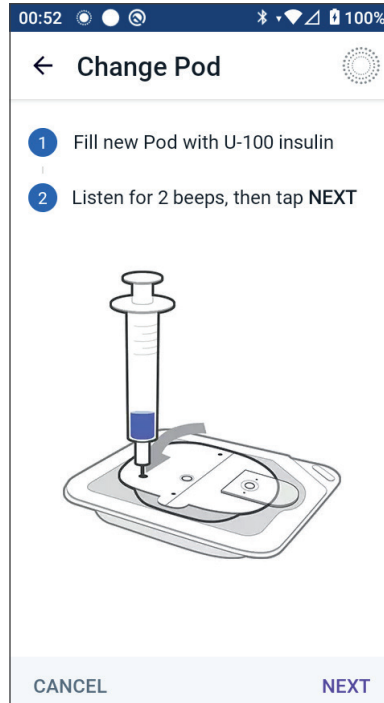

2. Tap NEXT.
 - If more than one, non-paired, filled Omnipod 5 Pod is in range, the Omnipod 5 App informs you of this and prevents you from completing activation. Move at least 6 m (20 ft) away from any other filled Omnipod 5 Pod and tap TRY AGAIN.
 - Only Omnipod 5 Pods are compatible with the Omnipod 5 System. If you try to use an older Pod that cannot communicate with the system, the Omnipod 5 App informs you of this and prevents you from completing activation. Tap DISCARD POD and restart Pod activation with an Omnipod 5 Pod.
 - If the Omnipod 5 App is able to communicate with the Pod but detects an incompatible Pod, the Omnipod 5 App informs you of this and prevents you from completing activation. Tap DISCARD POD and restart Pod activation with an Omnipod 5 Pod.

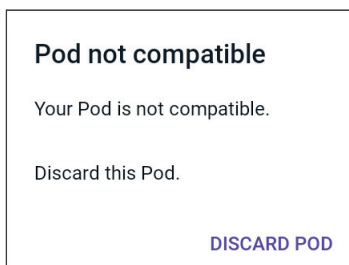
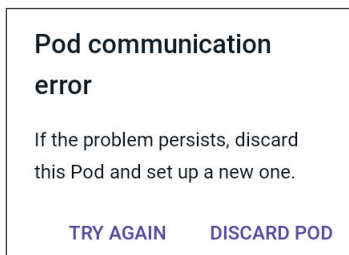
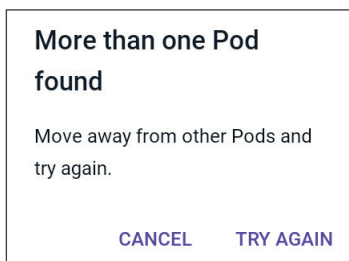

3. Listen for the tone from the Omnipod 5 App, which indicates the Pod is activated and ready to be applied.

Note: After activating a Pod, the Omnipod 5 App should always be able to communicate with a Pod that is up to 1.5 m (5 ft) away. Depending on the location, the Omnipod 5 App may be able to communicate with a Pod that is as much as 15 m (50 ft) away.

Note: After activating, the Pod beeps every 5 minutes until you apply it. If you do not apply it and do not begin insulin delivery within 60 minutes after activating, the Pod becomes unusable.

If you see a communication error message when you attempt to activate your Pod, and you are not using an older Pod, see “Error when activating a Pod” on page 376.

Prepare the Pod Site

Caution: ALWAYS rotate insulin infusion sites to help prevent infusion site complications like scar tissue and infection. Rotating insulin infusion sites reduces the risk of scarring. Using a site with scar tissue can lead to problems with insulin absorption.

Select the Pod infusion site (screen step **3**):

Guidelines for Pod site selection

Discuss suitable Pod placement sites with your healthcare provider using the following guidelines:

- Place at least 8 cm (3 inches) from your Sensor site, as indicated in your *Dexcom G6 CGM System Instructions for Use*.
- Place at least 2.5 cm (1 in) from your FreeStyle Libre 2 Plus Sensor, as indicated in your *FreeStyle Libre 2 Plus User's Manual*.
- Place within the line of sight of the Sensor for the best connectivity.

Note: Line of sight means that the Pod and Sensor are worn on the same side of the body in such a way that the two devices can “see” one another without your body blocking their communication.

- Ideal sites have a layer of fatty tissue.
- Ideal sites offer easy access and viewing.
- The site should be at least 2.5 cm (1 in) away from the previous site to avoid skin irritation.
- The site should be at least 5 cm (2 in) away from your navel.
- Avoid sites where belts, waistbands or tight clothing may rub against or dislodge the Pod.
- Avoid sites where the Pod will be affected by folds of skin.
- Avoid placing the Pod over a mole, tattoo or scar, where insulin absorption may be reduced.
- Avoid areas of the skin with an active infection.

Pod site examples

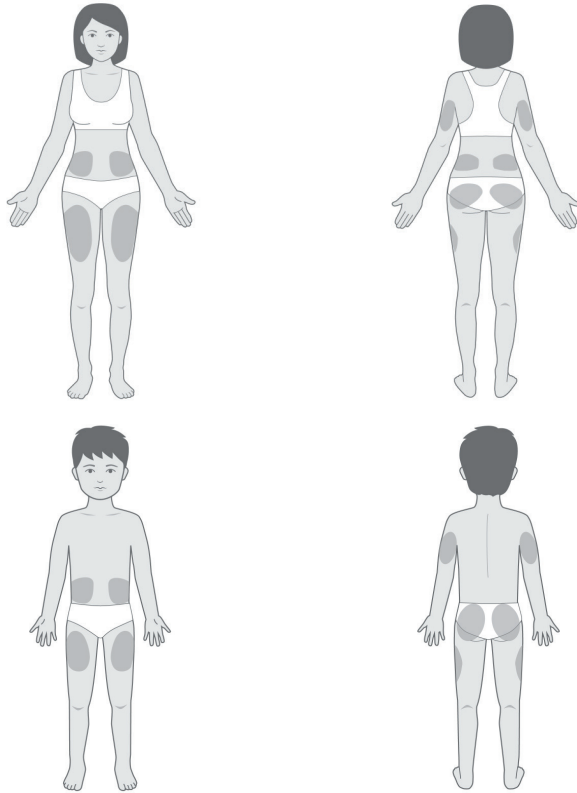

Pod site map (optional)

The Pod site map is an optional feature that helps you track your current and recent Pod site locations.

1. Tap RECORD POD SITE to bring up the Record Pod Site screen.
2. Tap the FRONT or BACK tab to select an area of your body for your Pod. To help you avoid recent Pod sites, the screen shows the two most recent dates that each site was selected.
3. Tap a circle to indicate the location on your body where you will place your new Pod. A blue dot appears inside the selected circle. Tap again to deselect the location.

5 Activating and Changing Your Pod

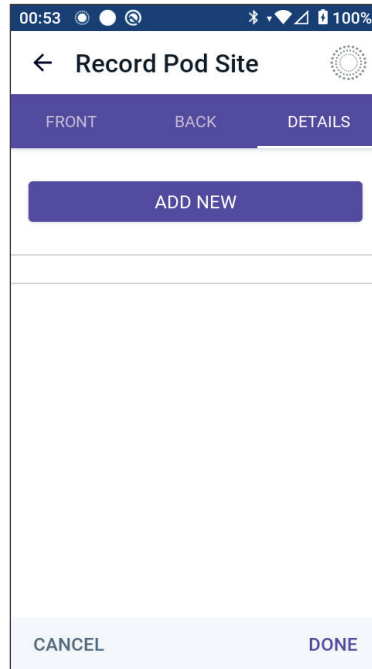
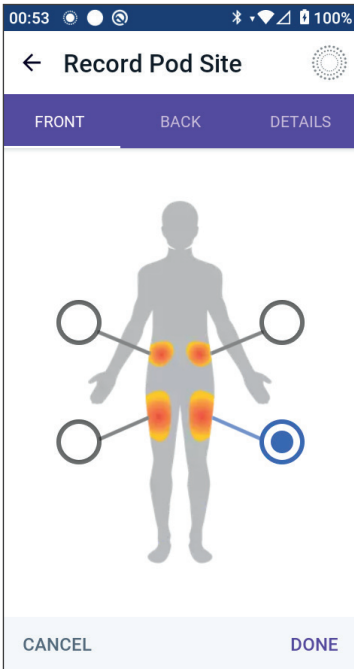

4. Tap the DETAILS tab to add a detail about the placement of this Pod. For example, you could add a detail that says “Facing up” or “Facing down” to describe the Pod’s orientation.
 - a. To add a new detail, tap ADD NEW and type in the new detail. Tap ADD when done. The new detail is added to the list.
 - b. Select a detail for the new Pod by tapping the circle next to that detail. You may only add one detail for each Pod. Tap again to deselect the detail.

Note: To delete a site detail, tap the  next to the detail.
5. Tap DONE when finished to return to the Change Pod screen.

Prepare the infusion site

To reduce the risk of infection at the infusion site:

1. Wash your hands with soap and water.
2. Wash your selected infusion site with soap and water.

Note: Antibacterial soap may irritate skin, especially at the infusion site. Ask your healthcare provider how to treat any skin irritation.
3. Dry the infusion site with a clean towel.
4. Use an alcohol prep swab to disinfect the infusion site. Start at the centre of the site and gently rub outwards in a circular motion.

- Let the infusion site air-dry thoroughly. Do not blow on the site to dry it.

Remove the Pod's Tab

Warning: DO NOT apply a Pod if you see the cannula is extended beyond the adhesive backing after the tab on the Pod is removed. This cannula cannot be inserted, resulting in under-delivery of insulin, which could lead to hyperglycaemia.

Remove the Pod's tab (screen step 4):

- Turn the Pod so the tab is up and facing you.
- Place your thumb on the bottom (flat edge) of the tab and pull the tab upwards. The tab snaps off. Throw the tab away.

When you remove the tab, a drop of insulin may be visible at the end of the cannula or in the well.

- If any of the following apply, tap **CANCEL** and then dispose of the Pod and begin again with a new Pod:
 - The Pod is accidentally dropped, as this could mean the Pod is no longer sterile.
 - The Pod or its adhesive pad is wet, dirty or damaged.
 - The cannula extends beyond the adhesive backing when the tab is removed.
- Using the pull tabs, remove the white paper backing covering the adhesive pad. Be careful not to remove the adhesive pad itself. Do not allow the adhesive to fold back on itself.

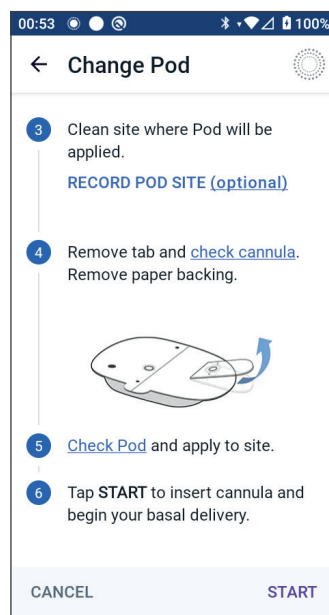

Apply the Pod

Inspect and apply the Pod (screen step 5):

1. Examine the Pod. Tap CANCEL and dispose of the Pod if the adhesive pad is folded, torn or damaged, and begin again with a new Pod.

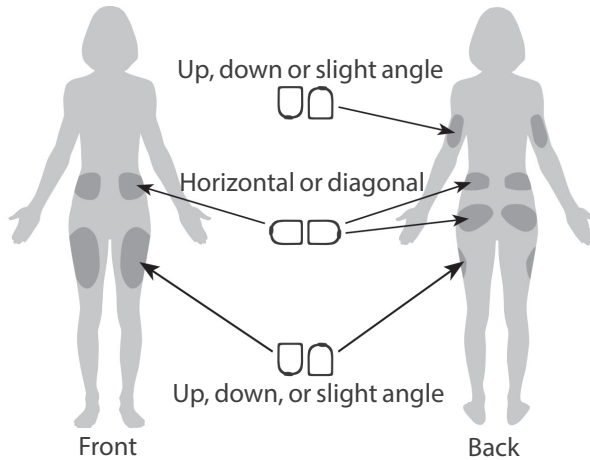

2. Orientate the Pod so it is:

- Horizontal or diagonal on your abdomen, hip, lower back or buttocks.
- Up and down or at a slight angle on your upper arm or thigh.
- For optimal connectivity, the Pod should be placed within the line of sight of the Sensor. The Bluetooth connection between the Sensor and the Pod does not travel well through the body. Keeping both devices within the line of sight allows for consistent Sensor communication with the Pod.

Note: Line of sight means that the Pod and Sensor are worn on the same side of the body in such a way that the two devices can “see” one another without your body blocking their communication.

3. Apply the Pod to the selected infusion site, pressing down firmly to secure the Pod to your skin.

The adhesive is designed for one-time use. After a Pod is placed on your body, you cannot move that Pod to another infusion site.

Note: The Pod’s adhesive keeps it securely in place for up to 3 days. However, if necessary, several products are available to help with peeling adhesive. Ask your healthcare provider about these products. Avoid getting any lotion, creams, sprays or oils near the infusion site as these products may loosen the adhesive.

Begin Insulin Delivery

Caution: ALWAYS apply the Pod as directed. If you are applying a Pod in a place that does not have a lot of fatty tissue, squeeze the skin around the Pod until after the cannula has been inserted. Blockages (occlusions) may result if you do not use this technique for lean areas.

Begin insulin delivery (screen step **6**):

1. If you applied the Pod to a lean area, squeeze the skin around the Pod.
2. Tap START to insert the cannula.

Confirm Pod is securely attached

1. Confirm that the Pod is securely attached to your body, then tap YES.
2. If you are squeezing your skin, stop squeezing when the Omnipod 5 App asks if the cannula is properly inserted.

5.5 Checking Your Infusion Site

Warning: ALWAYS check the infusion site often to make sure the cannula is properly inserted and secured to the Pod. Verify that there is no wetness or scent of insulin, which may indicate that the cannula has been dislodged. An improperly inserted, loose or dislodged cannula could result in under-delivery of insulin, which can lead to hyperglycaemia.

Warning: NEVER attempt to inject insulin (or anything else) into the fill port while the Pod is on your body. Attempting to do so could result in over-delivery or under-delivery of insulin, which can lead to hypoglycaemia or hyperglycaemia.

Following insertion of the cannula, check the Pod and infusion site:

1. Look through the viewing window on the edge of the Pod to verify that the cannula is inserted into the skin. The cannula is tinted light blue.
2. Verify that there is a pink colour on top of the Pod. This is an additional check that the cannula was inserted.

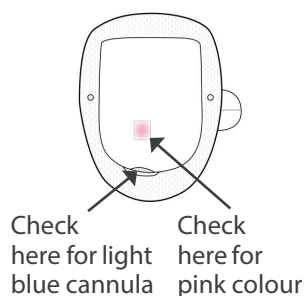

5 Activating and Changing Your Pod

3. Verify that there is no wetness or scent of insulin at the infusion site. The presence of either may indicate that the cannula has dislodged.
4. If the cannula is not properly inserted, tap NO. Then tap DEACTIVATE POD. Restart the process with a new Pod.
5. If the cannula is properly inserted, tap YES.

Pod setup is complete. The screen shows details about the active Pod and a list of Reminders.

Once the cannula is inserted, the Pod automatically fills the cannula with insulin. The Pod then begins delivering the basal rate of insulin according to the Basal Programme in progress.

The cannula can be inserted only once with each Pod.

6. Review the list of active Reminders, then tap CLOSE.

Caution: ALWAYS check the alarm function when you change the Pod if you suspect any issue with the Pod's sounds to ensure you don't miss important alarms during use (see "Check alarms" on page 157).

5.6 Switching to Automated Mode

An active Pod and Dexcom G6 Transmitter serial number (SN) or paired FreeStyle Libre 2 Plus Sensor are required to switch to Automated Mode. If you have an active Dexcom G6 Transmitter serial number (SN) or a FreeStyle Libre 2 Plus Sensor paired to the Omnipod 5 App, you will be prompted to switch to Automated Mode after activating your Pod.

To switch to Automated Mode:

- Tap YES.

To continue in Manual Mode:

- Tap NO.

You can switch from Manual Mode to Automated Mode at a later time.

See "22.1 Switching from Manual Mode to Automated Mode" on page 318.

Note: After switching to Automated Mode, you may see Automated Mode: Limited until sensor glucose values are available. See "21.5 About Automated Mode: Limited" on page 312.

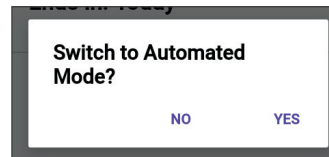

5.7 Deactivating an Active Pod

Warning: DO NOT apply a new Pod until you have deactivated and removed the old Pod. A Pod that is not deactivated properly can continue to deliver insulin as programmed, putting you at risk of over-delivery of insulin, which can lead to hypoglycaemia.

Caution: NEVER reuse the Pod or fill syringe or try to use a fill syringe that did not come with your Pod. Always dispose of the used Pod and fill syringe according to local disposal guidelines. Only use a new Pod with the fill syringe included with each Pod change. Always carry supplies to perform a Pod change should you need to replace your Pod at any time.

To deactivate and remove an active Pod:

1. Navigate to the Pod change screen:

Home > POD INFO tab >
VIEW POD DETAILS

or

Menu button (☰) > Pod.

2. Tap CHANGE POD, then tap DEACTIVATE POD.

If a Temp Basal, Extended Bolus or the Activity feature was in progress, it is cancelled now.

If you see a communication error message, see “Error when deactivating a Pod” on page 376.

When you deactivate your Pod, the system exits Automated Mode.

When the new Pod is activated, the system will be in Manual Mode;

however, you will be prompted to enter Automated Mode if you have a Dexcom G6 Transmitter serial number (SN) entered or a FreeStyle Libre 2 Plus Sensor paired to the Omnipod 5 App.

3. Remove the deactivated Pod from your body:
 - a. Gently lift the edges of the adhesive tape from your skin and remove the entire Pod.

Tip: Remove the Pod slowly to help avoid possible skin irritation.

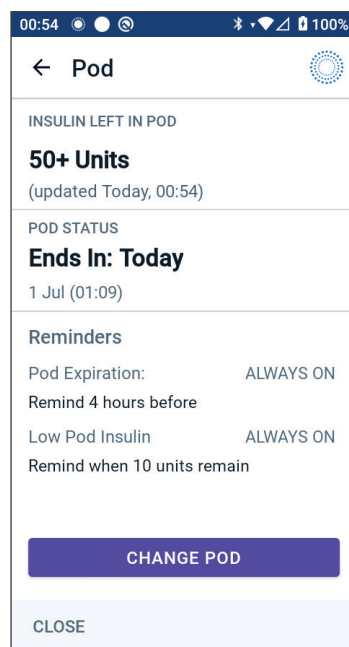

5 Activating and Changing Your Pod

- b. Use soap and water to remove any adhesive that remains on the skin or, if necessary, use an adhesive remover.
 - c. Check the infusion site for signs of infection (see “Avoiding Infusion Site Infections” on page 92).
 - d. Dispose of the used Pod according to local waste disposal regulations.
4. To activate a new Pod, tap SET UP NEW POD.

5.8 More Information about Pod Use

Avoiding Infusion Site Infections

Caution: ALWAYS rotate insulin infusion sites to help prevent infusion site complications like scar tissue and infection. Rotating insulin infusion sites reduces the risk of scarring. Using a site with scar tissue can lead to problems with insulin absorption.

Caution: DO NOT use a Pod if the sterile packaging is open or damaged, the Pod has been dropped after removal from the package or the Pod is expired, as the Pod may not work properly and increase your risk of infection.

Caution: ALWAYS follow these steps in preparing your site. If your site is not cleaned properly or if your hands are dirty, you increase your risk of infection.

- Wash your hands.
- Clean the top of the insulin vial with an alcohol prep swab.
- Clean your infusion site with soap and water or an alcohol prep swab, and let it dry completely.
- Keep sterile materials away from any possible contamination.

Caution: ALWAYS check for signs of infection often. If an infusion site shows signs of infection:

- Immediately remove the Pod and apply a new Pod at a different infusion site.
- Contact your healthcare provider. Treat the infection according to instructions from your healthcare provider.

If you see blood in your cannula, check your glucose more frequently to ensure insulin delivery has not been affected. If you experience unexpected high glucose, change your Pod.

Check the infusion site at least once a day:

- Be aware of signs of infection, including pain, swelling, redness, discharge or heat at the infusion site. If you suspect an infection, immediately remove the Pod and apply a new Pod in a different location. Then contact your healthcare provider.

If you observe any problems with the Pod, deactivate the Pod and activate a new one.

Additional Information

Tip: Develop a routine so you can change your Pod at a convenient time. If you know of an upcoming event that could interfere with changing your Pod, you can change your Pod early to avoid a disruption in insulin delivery.

For additional information on using your Pods as effectively as possible, see the following sections:

- To learn about caring for your Pod, see “14.1 Pod and Insulin Storage and Care” on page 184.
- To learn about the Pod alarms, see page 149.
- To learn how to silence a Pod alarm (see “13.9 Silencing Unresolved Alarms” on page 179).
- To understand the Pod’s informational and notification beeps, including which beeps are optional, see “13.11 Reminder Notifications List” on page 181 and “13.4 Informational Sounds and Vibrations” on page 154.
- To understand how to handle situations where the Omnipod 5 App cannot communicate with your Pod, see “26.5 Pod Communication Issues – “Try Again”” on page 374.
- If the Home: POD INFO tab says “No Pod Communication:”
 - To find the last time the Omnipod 5 App successfully communicated with the Pod, navigate to: Menu button (☰) > Pod.
 - If you are unable to restore communication with the Pod and want to change to a new Pod, navigate to: Menu button (☰) > Pod > CHANGE POD.

This page intentionally left blank.

CHAPTER 6

Basal Programmes

Contents

6.1 About Basal Programmes	96
6.2 Reviewing All Basal Programmes	96
6.3 Creating New Basal Programmes	97
6.4 Editing a Basal Programme.....	97
6.5 Deleting a Basal Programme	98
6.6 Switching to a Different Basal Programme	99
6.7 Basal Insulin Delivery.....	99
Manual Mode Basal Programmes.....	100

6.1 About Basal Programmes

While in Manual Mode, Basal Programmes are used to deliver a steady amount of insulin throughout the day. This is known as your basal insulin. Different days can have different routines. The Omnipod 5 System lets you create different Basal Programmes for your different routines. For example, you may use one Basal Programme on weekdays and a different one on weekends.

Before you create or change a Basal Programme, do the following:

- Cancel your Temp Basal if it is running. See “7.3 Cancelling a Temp Basal or Temp Basal Preset” on page 105.
- Switch to Manual Mode if currently using Automated Mode. See “22.2 Switching from Automated Mode to Manual Mode” on page 320.

Tip: Write a list of the basal segments to guide you through entering the values for each segment. You can write this list on the pages at the end of this *Technical User Guide*.

6.2 Reviewing All Basal Programmes

To review all Basal Programmes:

1. Navigate to the list of Basal Programmes:
Menu button (☰) > Basal Programmes
A list of Basal Programmes appears with the Basal Programme in progress at the top.
2. Scroll up or down as needed to see additional Basal Programmes.
3. Tap on the name of a saved Basal Programme to see its graph and basal rates. Tap outside the graph to close that graph.

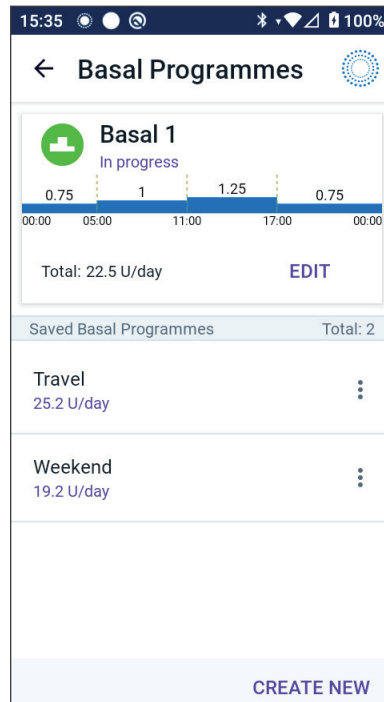



6.3 Creating New Basal Programmes

To create a new Basal Programme:

1. Navigate to the Create Basal Programme screen:
Menu button () > Basal Programmes
2. Tap CREATE NEW.
Note: If you already have 12 Basal Programmes, CREATE NEW does not appear. If necessary, you can delete an existing Basal Programme. See “6.5 Deleting a Basal Programme” on page 98.
3. See “Create a Basal Programme” on page 67 to continue creating your new Basal Programme.
4. If you have an active Pod and you want to use the new Basal Programme now, tap START to start using the new Basal Programme. If you do not want to use the new Basal Programme now, tap NOT NOW.

6.4 Editing a Basal Programme

To edit a Basal Programme:

1. Navigate to the list of Basal Programmes:
Menu button () > Basal Programmes
2. Select the Basal Programme you want to edit. Scroll up or down as necessary to locate the Basal Programme.
 - To edit the Basal Programme in progress, tap EDIT beneath the graph of the programme in progress. Then tap PAUSE INSULIN.
 - To edit a saved Basal Programme, tap the Options button () next to the Basal Programme you want to edit. Then tap Edit.

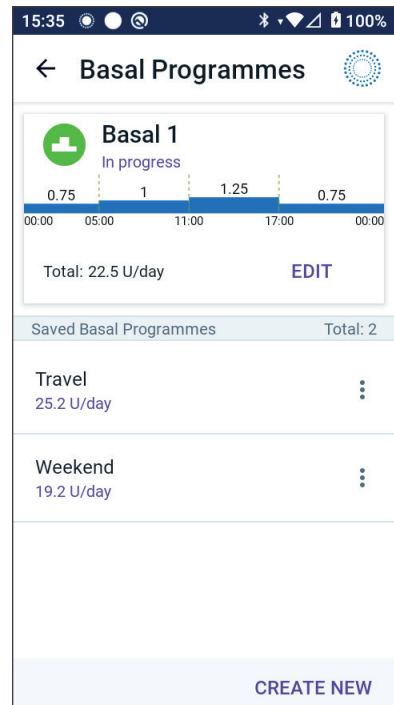



6 Basal Programmes

3. To rename the Basal Programme, tap the Programme Name field and enter the new name.
4. Tap DONE.
5. Tap NEXT.
6. See steps 2 - 7 of “6.2 Reviewing All Basal Programmes” on page 96 to continue editing your Basal Programme.
7. To activate the newly edited Basal Programme:
 - If you edited the Basal Programme in progress, tap START INSULIN.
 - If you edited a saved Basal Programme and want to start it, tap START.
8. If you do not want to start the newly edited Basal Programme, tap NOT NOW.

6.5 Deleting a Basal Programme



You can only delete a Basal Programme that is not in progress. To delete a Basal Programme:

1. Navigate to the list of Basal Programmes:
Menu button () > Basal Programmes
2. Tap the Options button () next to the Basal Programme you want to delete.
3. Tap Delete.
4. Tap DELETE to confirm deletion of the Basal Programme.

Note: Always make sure you are deleting the correct Basal Programme. Once deleted, the action cannot be undone and you will have to recreate the Basal Programme if needed.

6.6 Switching to a Different Basal Programme

To switch to a different Basal Programme:

1. Navigate to: Menu button () > Basal Programmes.
A list of Basal Programmes appears with the Basal Programme in progress at the top.
2. Select a different Basal Programme in one of the following ways:
 - To see a graph of a saved Basal Programme prior to activating it, tap on the name of that Basal Programme. Then tap **START**.
Tip: Double-tap the graph to see an expanded view of the Basal Programme. Swipe left and right to view basal rates for later or earlier times.
 - Tap the Options button () to the right of a saved Basal Programme, then tap **START**.
3. Tap **START** again to start the newly selected Basal Programme.

6.7 Basal Insulin Delivery

Even without eating, our bodies need a small, constant supply of insulin for normal daily living, which is referred to as 'basal' insulin. In people without diabetes, the pancreas continuously delivers this basal insulin. For people using the Omnipod 5 System, the Pod can mimic the pancreas of a person without diabetes by delivering basal insulin continuously as you wear the Pod.

About half of a person's Total Daily Insulin (TDI) dose typically comes from basal insulin delivery; the other half typically comes from bolus doses.

In the Omnipod 5 System, basal delivery occurs differently depending on which of the two modes you are operating in: Manual or Automated.

6 Basal Programmes

Manual Mode Basal Programmes

A basal rate is the number of units of insulin delivered per hour.

A basal segment defines the time of day during which a given basal rate is delivered.

A collection of basal segments covering a midnight-to-midnight period is called a “Basal Programme”. In other words, a Basal Programme describes the rate of insulin delivery throughout an entire 24-hour period.

This figure shows a Basal Programme with three basal segments that deliver 7.4 U total in a 24-hour period.

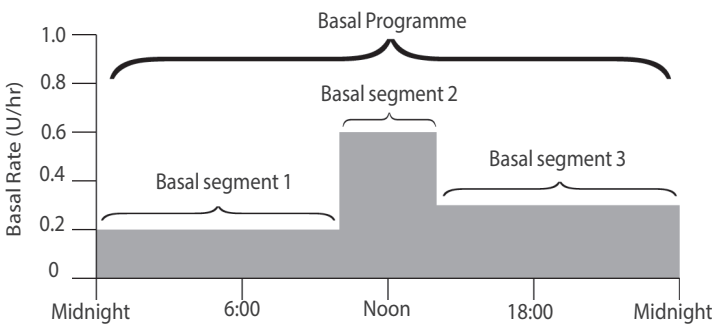

Insulin needs vary throughout the day. Therefore, most people set their basal rates to deliver more or less insulin at certain times of the day. For example, you could deliver a lower rate of insulin during the night and a higher rate during the day.

In order to create the Basal Programme shown in the example above, the following basal segments are programmed into the Omnipod 5 App:

Segment	Basal rate	
1: Midnight–10:00	0.20 U/hr	Between midnight and 10:00, the Pod delivers 0.20 units of insulin per hour.
2: 10:00–14:00	0.60 U/hr	Between 10:00 and 14:00, the Pod delivers 0.60 units of insulin per hour.
3: 14:00–midnight	0.30 U/hr	Between 14:00 and midnight, the Pod delivers 0.30 units of insulin per hour.

You may have different routines on different days of the week; for example, your weekend routine may differ from your weekday routine. To handle these predictable changes in your routine, you can create up to 12 different Basal Programmes (see “6.3 Creating New Basal Programmes” on page 97).

CHAPTER 7

Temporary Basal Rates and Presets

Contents

7.1 About Temporary Basal Rates	102
7.2 Starting a Temp Basal	103
7.3 Cancelling a Temp Basal or Temp Basal Preset	105
7.4 Creating a New Temp Basal Preset	105
7.5 Editing a Temp Basal Preset	106
7.6 Deleting a Temp Basal Preset	107
7.7 Temporary Basal Rates Delivery	107
Temp Basal settings: Units per hour (U/hr) or per cent (%)	108
Temp Basal limitations	109
Temp Basal Presets	110

7.1 About Temporary Basal Rates

When in Manual Mode, you can use a temporary basal rate, or “Temp Basal”, to handle a temporary change in your routine. For example, a Temp Basal can be used when you are exercising or when you are sick. When a Temp Basal ends, the Pod will start delivering the scheduled Basal Programme.

If there is a Temp Basal that you use often, you can create a “Temp Basal Preset” for rapid activation in the future. To create a Temp Basal Preset, see page 105. You can create up to 12 Temp Basal Presets.

To turn ON or OFF the ability to start Temp Basals, or to change between specifying the Temp Basal as a percentage or in U/hr, see page 130.

Tip: By default, the Omnipod 5 App or Pod sounds a tone at the beginning and end of a Temp Basal and every 60 minutes while a Temp Basal is running. To turn these ON or OFF, see “13.3 Sounds and Vibrations” on page 153.



Before you create or change a temporary basal rate, do the following:

- Temp Basal setting must be ON. If it is OFF, see “10.3 Basal and Temp Basal Settings” on page 130.
- If the Omnipod 5 System is currently in Automated Mode, switch to Manual Mode. See “22.2 Switching from Automated Mode to Manual Mode” on page 320.

7.2 Starting a Temp Basal

Note: You cannot start or cancel a Temp Basal during an immediate bolus, but you can start or cancel a Temp Basal while an Extended Bolus is in progress.

To start a Temp Basal:

1. Navigate to:
Menu button () > Set Temp Basal
The screen shows a graph of the Basal Programme in progress.
2. Tap the Basal Rate field and scroll to the desired change in the basal rate:
 - If using a per cent (%) change:
An UP ARROW () indicates **increasing** the basal rate above that of the Basal Programme in progress.
A DOWN ARROW () indicates **decreasing** the basal rate below that of the Basal Programme in progress.
 - If using a flat rate (U/hr), scroll to select the basal rate for the entire Temp Basal period.

Note: To change whether Temp Basals are configured as per cent (%) or U/hr, see “10.3 Basal and Temp Basal Settings” on page 130.

Note: The scroll wheel will not scroll above your Maximum Basal Rate. To adjust your Maximum Basal Rate, see “Maximum Basal Rate” on page 130.

Tip: You can turn OFF insulin delivery for the duration of the Temp Basal by setting a decrease of 100% or setting the Temp Basal to 0 U/hr. For more information, see “Temp Basal limitations” on page 109 and “7.7 Temporary Basal Rates Delivery” on page 107.

3. Tap the Duration field and scroll to the desired Temp Basal duration (between 30 minutes and 12 hours).

7 Temporary Basal Rates and Presets

- Examine the Temp Basal graph at the top of the screen. The proposed Temp Basal is displayed over the Basal Programme in progress.
 - The lighter blue shaded area shows the proposed Temp Basal rate for each segment.
 - If you set a decrease, the Basal Programme in progress is shown as a horizontal dotted line.
- Tap CONFIRM to continue.
- Review the Temp Basal details. If corrections are needed, tap on the row to change. Then enter your corrections and confirm them.
- To start the Temp Basal, tap START. Then tap START again.

Once the Temp Basal starts, the Home screen's INSULIN tab is highlighted in light blue and is renamed to TEMP ON, which indicates that the Temp Basal is in progress. The TEMP ON tab now shows that the Temp Basal is in progress, what the basal rate change is and how much time remains.

At the end of the Temp Basal time period, the Pod will go back to delivering the scheduled Basal Programme.

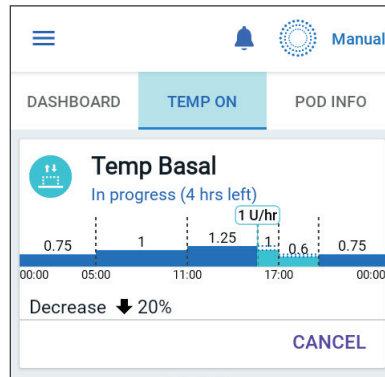
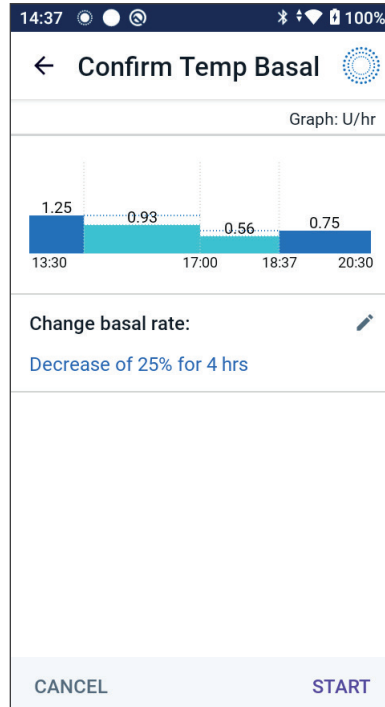

7.3 Cancelling a Temp Basal or Temp Basal Preset

A Temp Basal stops automatically at the end of its time period and the last scheduled Basal Programme starts.

To cancel a Temp Basal before the end of its time period:

1. Navigate to the Home screen's TEMP ON tab.
2. Tap CANCEL.
3. Tap YES to confirm cancellation. The Omnipod 5 App cancels the Temp Basal and starts the last scheduled Basal Programme.

7.4 Creating a New Temp Basal Preset

To create a new Temp Basal Preset:

1. Navigate to: Menu button (☰) > Temp Basal Presets.
2. Tap CREATE NEW.

Note: If you already have 12 Temp Basal Presets, CREATE NEW does not appear. If necessary, you can delete an existing preset.

3. Tap the Preset Name field and enter a descriptive name for your preset.
4. Tap DONE.

Note: The default name for the preset is "Temp Basal" followed by a number.

5. Tap NEXT.
6. Tap the Basal Rate field and scroll to the desired value.

- If using a per cent (%) change:

An UP ARROW (↑) indicates **increasing** the basal rate above that of the Basal Programme in progress.

A DOWN ARROW (↓) indicates **decreasing** the basal rate below that of the Basal Programme in progress.

- If using a flat rate (U/hr), scroll the wheel to select the basal rate for the entire Temp Basal period.

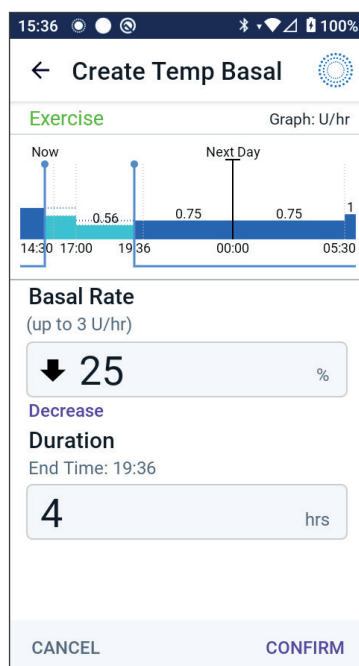



7 Temporary Basal Rates and Presets

7. Tap the Duration field and scroll to a duration for the preset. The temporary change to the Basal Programme is shown on the graph.
8. Tap CONFIRM.
9. Review the Temp Basal details. If corrections are needed, tap on the row to change. Then enter your corrections and confirm them.
10. Tap SAVE to save this as a Temp Basal Preset.
11. If you would like to start this Temp Basal now, tap START. Otherwise, tap NOT NOW.

7.5 Editing a Temp Basal Preset

Note: You cannot edit a Temp Basal Preset that is in progress.

To edit a Temp Basal Preset:

1. Navigate to the Temp Basal Presets screen:
Menu button () > Temp Basal Presets
2. Find the preset that you want to edit. Then tap the Options button () and tap Edit.
3. To rename the preset, tap the Preset Name field and enter the new name.
4. Tap DONE.
5. Tap NEXT.
6. Change the basal rate and duration as desired.
7. Tap CONFIRM.
8. Review the Temp Basal details. If corrections are needed, tap on the row to change. Then enter your corrections and confirm them.
9. Tap SAVE to save your changes.
10. If you would like to start this Temp Basal now, tap START. Otherwise, tap NOT NOW.

7.6 Deleting a Temp Basal Preset

Note: You cannot delete a Temp Basal Preset that is in progress.

To delete a Temp Basal Preset:

1. Navigate to the Temp Basal Presets screen:
Menu button (≡) > Temp Basal Presets
2. Tap the Options button (⋮) next to the preset you want to delete.
3. Tap DELETE.
4. Tap DELETE to confirm deletion of the preset.

Note: Always make sure you are deleting the correct Temp Basal Preset. Once deleted, the action cannot be undone and you will have to recreate the Temp Basal Preset if needed.

7.7 Temporary Basal Rates Delivery

A Temp Basal lets you override the currently running Basal Programme by setting a different basal rate for a predetermined period of time. This feature is only available in Manual Mode.

For example, if you are going cross-country skiing for several hours, you could set a Temp Basal to lower your basal rate during and after your exercise (see “Temporary Basal Rates and Presets” on page 101).

Temp Basals can last from 30 minutes to 12 hours. At the end of the specified time, the Pod automatically goes back to the programmed basal rate.

7 Temporary Basal Rates and Presets

Temp Basal settings: Units per hour (U/hr) or per cent (%)

Temp Basals can be set using per cent (%) or units per hour (U/hr).

Setting Temp Basals to units per hour (U/hr) means that the Pod delivers insulin at a flat rate for the duration of the Temp Basal. In other words, the details of the currently scheduled Basal Programme are ignored during these Temp Basals.

Setting Temp Basals to per cent (%) means that insulin delivery follows the pattern defined by the currently scheduled Basal Programme, but increases or decreases the insulin delivery by the specified percentage. For example, a 50% increase raises the Basal Programme's insulin delivery by 50%, while a 50% decrease lowers the Basal Programme's insulin delivery by 50%.

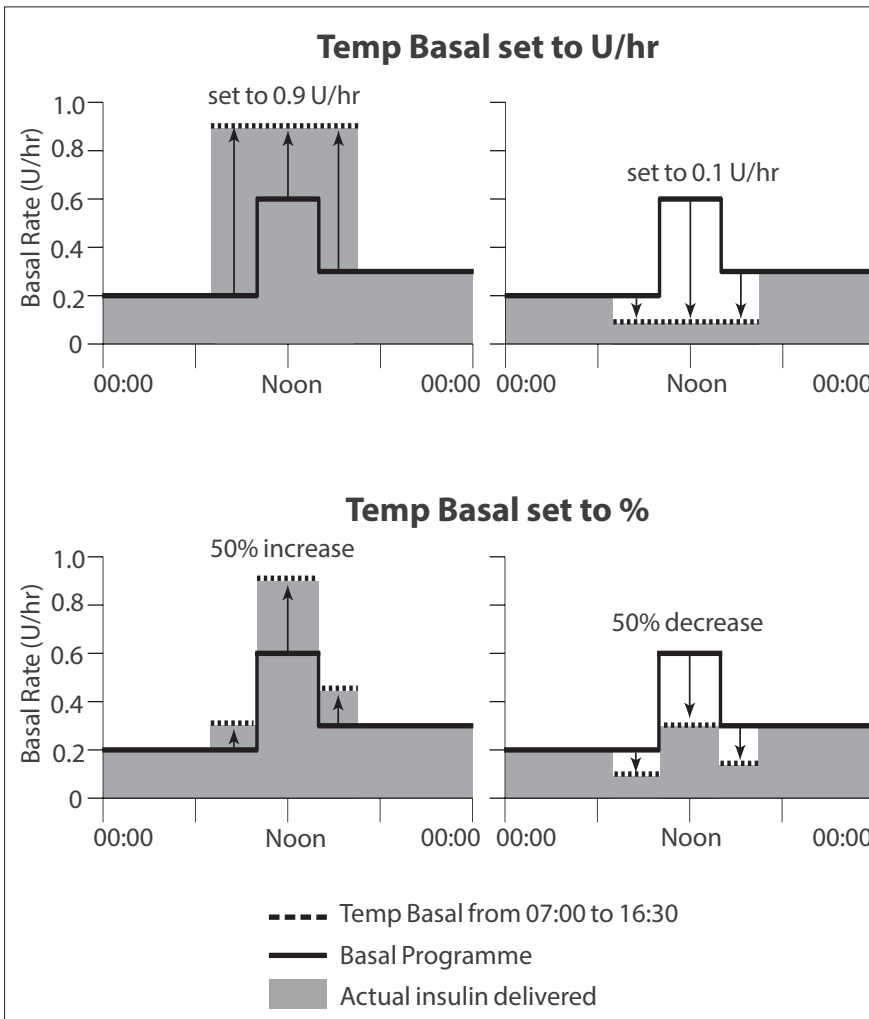

The calculations for the 50% increase Temp Basal in the example above figure are:

Segment boundaries*	Basal rate of Basal Programme (U/hr)	50% increase (U/hr)	Resulting Temp Basal rate: (U/hr)
Midnight–07:00	0.20		
07:00–10:00	0.20	$0.20 \times 50\% = 0.10$	$0.20 + 0.10 = 0.30$
10:00–14:00	0.60	$0.60 \times 50\% = 0.30$	$0.60 + 0.30 = 0.90$
14:00–16:30	0.30	$0.30 \times 50\% = 0.15$	$0.30 + 0.15 = 0.45$
16:30–midnight	0.30		

* Segments are defined by the currently scheduled Basal Programme.

Temp Basal limitations

Prohibited Temp Basals: You cannot set a Temp Basal of 0%, as there would be no change from the Basal Programme in progress.

Maximum Temp Basal:

- When using per cent (%), you can set the Temp Basal up to 95% more than your Basal Programme in progress's rate with the following exception: You cannot set a Temp Basal that would go above your Maximum Basal Rate during any time segment covered by the Temp Basal duration.
- When using a flat rate (U/hr), you cannot set a Temp Basal above your Maximum Basal Rate.

Temp Basals that turn off basal insulin delivery: When using per cent (%), if you set a decrease that results in a flow of less than 0.05 U/hr for a segment, the Omnipod 5 App informs you that you will receive 0 U/hr of insulin for one or more segments.

If the Temp Basal is long enough, you will eventually receive some insulin. This is because the Pod delivers insulin in 0.05 U pulses.

For example, if the flow rate for a basal segment is 0.10 U/hr and you create a Temp Basal with a 60% decrease for:

- One hour, the resulting flow rate of 0.04 U/hr results in no insulin being delivered for the one-hour duration of the Temp Basal.
- Two hours, the resulting flow rate of 0.04 U/hr results in the delivery of 0 U insulin in the first hour and 0.05 U insulin in the second hour.

You can set a Temp Basal to turn off basal insulin delivery for a set period of time by using a 100% decrease or a flat rate of 0 U/hr. The Pod beeps at the start and end of a Temp Basal period of no basal insulin. You can still deliver boluses when using a Temp Basal to turn off basal insulin delivery.

7 Temporary Basal Rates and Presets

Tip: Using a Temp Basal to turn off basal insulin delivery is useful if you want your Basal Programme to automatically start when the Temp Basal ends.

Temp Basal Presets

Some temporary changes in your daily routine are easy to predict, and you may know from experience how they affect your insulin needs. For example, you might join a summer football league or attend an exercise class. For people who menstruate, your monthly hormonal change can affect glucose in a predictable manner.

To handle predictable, short-term changes, you can define Temp Basal Presets (see “Temporary Basal Rates and Presets” on page 101). Once stored, a Temp Basal Preset can be started quickly at a later time.

CHAPTER 8

Blood Glucose Readings

Contents

8.1 About Blood Glucose Readings	112
8.2 Entering Your Blood Glucose Reading	113
8.3 High and Low Blood Glucose Readings	114
How Blood Glucose Readings are Displayed	115

8.1 About Blood Glucose Readings

Warning: ALWAYS follow your healthcare provider's guidance on appropriate glucose monitoring to avoid hyperglycaemia and hypoglycaemia.

The Omnipod 5 System receives regular glucose values from the Sensor when you have connected either the Dexcom G6 Sensor or FreeStyle Libre 2 Plus Sensor to an active Pod. Once connected, sensor glucose values are displayed and can be used in the Omnipod 5 App in both Manual and Automated Modes. There may be times when you need to check your blood glucose using a separate BG meter. You may want to check your blood glucose if:

- You are experiencing symptoms of hypoglycaemia. See “Symptoms of hypoglycaemia (low glucose)” on page 197.
- You are experiencing symptoms of hyperglycaemia. See “Symptoms of hyperglycaemia (high glucose)” on page 200.
- You are experiencing symptoms that are not consistent with your sensor glucose values.
- You use a Dexcom G6 Sensor, and your Sensor requires calibration. For more information, refer to your *Dexcom G6 CGM System Instructions for Use*.
- You are not using a Sensor to monitor glucose.
- Your healthcare provider advises you to do so.

8.2 Entering Your Blood Glucose Reading

To enter your blood glucose reading:

1. Check your blood glucose following your BG meter's instructions for use.
2. Go to the Enter BG screen on your Omnipod 5 App:
Menu button (☰) > Enter BG
Or from the SmartBolus Calculator, tap the Glucose field.
3. Manually enter or edit a blood glucose value as follows:
 - a. Enter and confirm your blood glucose reading using the number pad.
 - b. Tap the tick symbol to close the number pad.

Note: When you enter a blood glucose reading above 33.3 mmol/L (600 mg/dL), the Omnipod 5 App stores it as "HIGH". When you enter a blood glucose reading below 1.1 mmol/L (20 mg/dL), the Omnipod 5 App stores it as "LOW".

4. After the blood glucose reading is entered, do one of the following:
 - Tap ADD TO CALCULATOR to save and enter the blood glucose reading into the SmartBolus Calculator.
Note: Until a blood glucose reading has been entered, or if insulin is paused, ADD TO CALCULATOR is disabled.
 - Tap SAVE to save the blood glucose reading in the history records. If you accessed this screen from the SmartBolus Calculator, SAVE does not appear.
 - Tap CANCEL, then YES, to exit the screen without saving the blood glucose reading.

The Omnipod 5 App records the current time as the time of the blood glucose reading.

8.3 High and Low Blood Glucose Readings

Warning: ALWAYS follow your healthcare provider's guidance on appropriate glucose monitoring to avoid hyperglycaemia and hypoglycaemia.

Warning: Glucose below 3.9 mmol/L (70 mg/dL) may indicate hypoglycaemia (low glucose). Glucose above 13.9 mmol/L (250 mg/dL) may indicate hyperglycaemia (high glucose). Follow your healthcare provider's suggestions for treatment.

Warning: ALWAYS promptly treat hypoglycaemia. Glucose at or below 3.1 mmol/L (55 mg/dL) indicates significant hypoglycaemia (very low glucose). If left untreated, this could lead to seizure, loss of consciousness and death. Follow your healthcare provider's recommendations for treatment.

Warning: ALWAYS promptly treat glucose below 3.9 mmol/L (70 mg/dL) (hypoglycaemia) according to your healthcare provider's recommendations. Symptoms of hypoglycaemia include weakness, sweating, nervousness, headache or confusion. If left untreated, hypoglycaemia could lead to seizure, loss of consciousness or death.

Warning: DO NOT wait to treat hypoglycaemia (low glucose) or symptoms of hypoglycaemia. Even if you cannot check your glucose, waiting to treat symptoms could lead to severe hypoglycaemia, which can lead to seizure, loss of consciousness or death.

Warning: ALWAYS promptly treat hyperglycaemia (high glucose) according to your healthcare provider's recommendations. Symptoms of hyperglycaemia include fatigue, thirst, excess urination or blurry vision. If left untreated, hyperglycaemia could lead to diabetic ketoacidosis (DKA) or death.

Warning: DO NOT wait to treat DKA. If left untreated, DKA can quickly lead to breathing difficulties, shock, coma or death.

Warning: ALWAYS treat "LOW" or "HIGH" sensor glucose values and blood glucose readings according to your healthcare provider's recommendations. These values can indicate potentially serious conditions requiring immediate medical attention. If left untreated, these situations can quickly lead to diabetic ketoacidosis (DKA), shock, coma or death.

If the blood glucose reading is HIGH or above 33.3 mmol/L (600 mg/dL), the Omnipod 5 App records "HIGH" in the history. This indicates severe hyperglycaemia (high glucose). If the blood glucose reading is LOW or below 1.1 mmol/L (20 mg/dL), the Omnipod 5 App records "LOW" in the history. This indicates severe hypoglycaemia (low glucose).

The Omnipod 5 App indicates high and low blood glucose readings as follows.

Glucose reading	Screen display
Above 33.3 mmol/L (600 mg/dL) or HIGH	HIGH
1.1–33.3 mmol/L (20–600 mg/dL)	<blood glucose reading>
0–1 mmol/L (0–19 mg/dL) or LOW	LOW

How Blood Glucose Readings are Displayed

The Omnipod 5 App displays the blood glucose reading with a colour. The text colour is:

- Yellow if your blood glucose is above your Glucose Goal Range.
- Green if your blood glucose is within your Glucose Goal Range.
- Red if your blood glucose is below your Glucose Goal Range.

To change your Glucose Goal Range, see page 140.

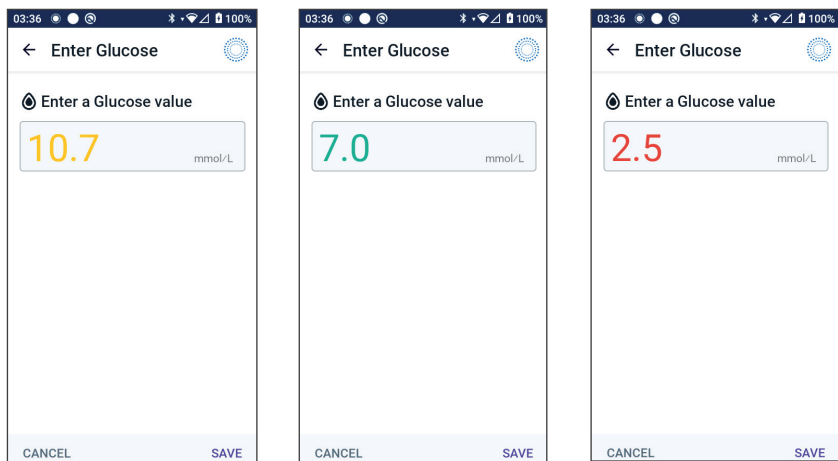

This page intentionally left blank.

CHAPTER 9

Pausing and Starting Insulin Delivery

Contents

9.1 Pausing Insulin Delivery	118
Pause insulin delivery	118
9.2 Methods to Temporarily Pause Insulin Delivery in Manual Mode	119
9.3 Starting Insulin Delivery	120
Start insulin delivery before the pause period ends	120
Start insulin delivery after the pause period ends	120

9 Pausing and Starting Insulin Delivery

9.1 Pausing Insulin Delivery

Caution: ALWAYS tap START INSULIN to start insulin delivery after a pause period has ended during Manual Mode use. Insulin delivery does not automatically start after a pause. If you do not start insulin delivery, you could develop hyperglycaemia.

Sometimes you may need to pause insulin delivery briefly. For example, you must pause insulin delivery prior to editing a Basal Programme in progress or changing the time zone. The Omnipod 5 System lets you pause all insulin delivery for up to two hours.

For the difference between pausing insulin delivery using the pause feature or the Temp Basal feature, see “9.2 Methods to Temporarily Pause Insulin Delivery in Manual Mode” on page 119.

Before you begin, do the following:

- You must be in Manual Mode to pause insulin. If you are currently using Automated Mode, see “22.1 Switching from Manual Mode to Automated Mode” on page 318.

Pause insulin delivery

To pause insulin delivery:

1. Navigate to:
Menu button (≡) > Pause Insulin.
2. Tap the Pause Insulin field. Scroll to specify how long to pause insulin. The paused time can last 0.5 hour, 1 hour, 1.5 hours, or 2 hours.
3. Tap PAUSE.
4. Tap YES to confirm that you want to pause all insulin delivery.

All basal insulin delivery is paused.

The Home screen displays a yellow banner stating that “Insulin delivery is paused”.

Note: The Pod beeps every 15 minutes throughout the pause period. At the end of the pause period, insulin delivery does not automatically start. The Pod and Omnipod 5 App notify you every minute for 3 minutes, and repeat this notification every 15 minutes until you have started insulin delivery.

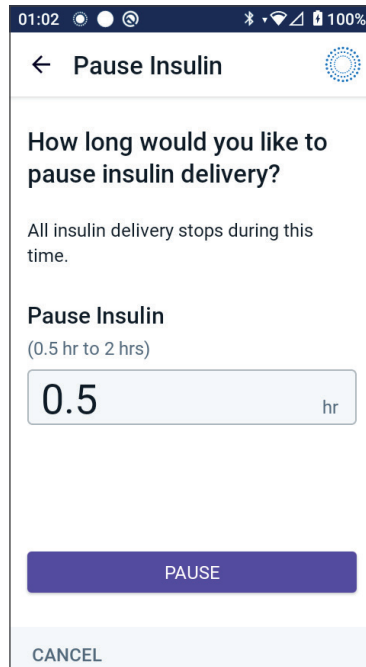

9.2 Methods to Temporarily Pause Insulin Delivery in Manual Mode

There may be times when you want to pause all insulin delivery, or at least all basal insulin delivery, for a period of time. If you do not want to deactivate your current Pod, you can request a temporary halt of insulin delivery as follows:

- Pause insulin delivery.
- Set a Temp Basal to turn off insulin delivery:

The following table compares these options for pausing insulin delivery.

	Pause insulin	Temp Basal of 0 U/hr
Effect on basal and bolus insulin delivery	No basal delivery No bolus delivery	No basal delivery Boluses allowed
Minimum duration for pausing insulin	30 min	30 min
Maximum duration for pausing insulin	2 hrs	12 hrs
Insulin delivery starts automatically	No	Yes
Screen display at the end of the specified duration	“Start insulin. The insulin pause period has ended”.	The middle tab of the Home screen now shows “Basal”, not “Temp Basal”
Beeps while insulin is paused	Every 15 min	At the beginning and every 60 min
Beeps at the end of the specified duration	Every 15 min until you tap Start	One beep, then insulin starts automatically
Must be used when	Editing a Basal Programme in progress Changing the time zone Testing alarm and vibrate feature	Use is never required
How to cancel the pause	Menu button (☰) > Start Insulin	Home: Temp Basal tab > CANCEL

9.3 Starting Insulin Delivery

Caution: ALWAYS tap START INSULIN to start insulin delivery after a pause period has ended during Manual Mode use. Insulin delivery does not automatically start after a pause. If you do not start insulin delivery, you could develop hyperglycaemia.

Start insulin delivery before the pause period ends

1. Navigate to:
Menu button (☰) > Start Insulin.
2. Tap START INSULIN to confirm restarting the Basal Programme scheduled for the current time.

The Omnipod 5 App beeps to confirm that insulin delivery has started.

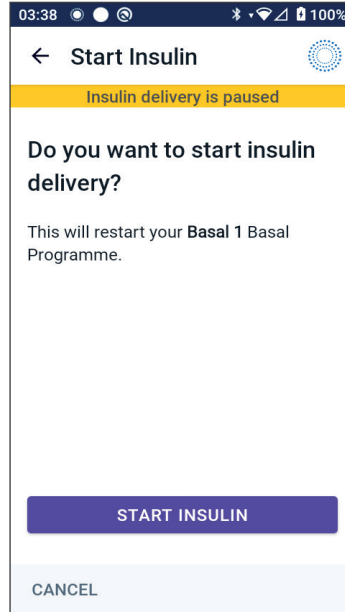

Start insulin delivery after the pause period ends

- Tap START INSULIN to start insulin delivery.

The Omnipod 5 App starts the Basal Programme that is scheduled for the current time and beeps to alert you that insulin delivery has started.

If you do not start insulin delivery immediately, this screen reappears and the Omnipod 5 App and Pod beep every 15 minutes until insulin delivery is started.

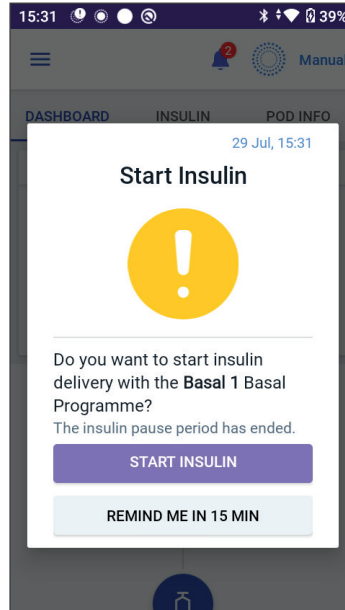

CHAPTER 10

Changing Settings

Contents

10.1 General Settings	123
Network Connectivity	123
Flight mode	123
Screen Display	124
Screen time-out	124
Screen brightness	124
Lock Screen	124
Lock screen message	124
Lock screen background	124
PIN	125
Time Change	125
Device time zone	125
Insulin delivery time zone	126
Language	127
Reset	127
10.2 Reminder Settings	127
Pod Expiry	128
Low Pod Insulin	128
Pod Shut-Off	128
Confidence Reminders	129
Programme Reminders	129
10.3 Basal and Temp Basal Settings	130
Maximum Basal Rate	130
Temp Basal	130

10.1 General Settings

Warning: DO NOT start to use your system or change your settings without adequate training and guidance from your healthcare provider. Initiating and adjusting settings incorrectly can result in over-delivery or under-delivery of insulin, which could lead to hypoglycaemia or hyperglycaemia. Settings that impact insulin delivery mainly include: Pod Shut-Off, basal rate(s), Max Basal Rate, Max Bolus, Correction Factor(s), Insulin-to-Carb (IC) Ratio(s), Minimum Glucose for Calculations, Target Glucose and Correct Above, and Duration of Insulin Action.

Network Connectivity

Flight Mode is a device setting that turns off mobile and Wi-Fi network connectivity. Flight Mode can be turned ON or OFF.

Note: Though the Omnipod 5 System does not require constant network connectivity, frequent connectivity (either mobile or Wi-Fi) is needed for optimal use of the system, such as if you typically share your glucose data with a care partner. Consider re-enabling Wi-Fi after turning on Flight Mode for optimal system use.

Flight mode

To turn Flight Mode ON or OFF on the Controller:

1. Navigate to: Menu button () > Settings > General.
2. Tap the Flight Mode toggle to turn Flight Mode ON or OFF.

Screen Display

Use the screen display settings to control the screen time-out and brightness.

Screen time-out

The Controller screen turns black if you have not used it for the specified amount of time in order to preserve battery power. To change the amount of time:

1. Navigate to:
Menu button () > Settings > General > Screen Time-Out.
2. Tap a desired amount of time to select it.
Tip: A shorter screen time-out extends the battery charge.
3. Tap SAVE.

Screen brightness

To adjust the brightness of the screen on the Controller:

1. Navigate to: Menu button () > Settings > General > Brightness.
2. Place your finger on the blue dot of the slider. Slide your finger to the right to increase the screen brightness. Slide your finger to the left to decrease the screen brightness.
Tip: Lower screen brightness extends the battery charge.

Lock Screen

You can edit your Controller's Lock screen message, background image and PIN, which help ensure that you are using the correct Controller.

Lock screen message

To change your Lock screen message:

1. Navigate to: Menu button () > Settings > General > Message.
2. Tap the Lock screen message field and enter the message you want the Controller to display when you turn it ON.
3. Tap SAVE.

Lock screen background

To change the background image on the Lock screen:

1. Navigate to: Menu button () > Settings > General > Background.
2. Tap the background image you want to use.
3. Tap SAVE.

PIN

To change your personal identification number or PIN:

1. Navigate to: Menu button () > Settings > General > PIN.
2. Enter your current PIN.
3. Enter the new four-digit PIN.

Tip: Tap the eye icon to display or hide the PIN.
4. Tap Done to accept the PIN.
5. Re-enter the new PIN, and then tap Done.

Note: To change your PIN, you must have mobile or Wi-Fi connectivity.

Note: If you have problems with your PIN, contact Customer Care. For contact information, see the Customer Care card at the front of this *Technical User Guide*.

Time Change

Caution: AVOID turning Automatic Time Zone OFF on the Controller. If you turn Automatic Time Zone OFF, your Controller will not be able to detect when your device time zone and insulin delivery time zone do not match. Delivering insulin based on a different time zone than your local time could cause errors in insulin delivery and data logging, which could lead to hypoglycaemia or hyperglycaemia.

A time change occurs when you are travelling to a different time zone or for daylight saving time. To help you manage time changes, your device's time zone is separate from your insulin delivery time zone as described in the table below.

Omnipod 5 App on:	Device Time Zone	Insulin Delivery Time Zone	Automatic Time Zone Setting: ON/OFF
Controller	Time shown on your Controller (status bar, lock screen)	Time shown in the Omnipod 5 App, insulin delivery is based on App time	Recommended ON

Device time zone

Your device time zone is the time displayed outside of the Omnipod 5 App on the status bar and the lock screen. Your device time will update automatically when you travel to a new time zone or for Daylight Saving Time when you have the Automatic Time Zone setting ON. It is recommended that you keep your Automatic Time Zone setting ON so your device time zone will always be your local time zone.

10 Changing Settings

To turn Automatic Time Zone ON or OFF:

1. Navigate to: Menu button () > Settings > General > Time Zone.
2. If you have an active Pod, tap PAUSE INSULIN and tap YES.
3. Tap Device Automatic Time Zone. Tap CONTINUE.
4. Tap the toggle to turn Automatic Time Zone detection ON or OFF.
Tip: Purple colour means the setting is ON. Grey means the setting is OFF.
5. When the device's Automatic Time Zone is OFF, you have access to the Controller time zone.
6. To change the time zone of the Controller, tap SELECT TIME ZONE and select the desired time zone from the list.

Insulin delivery time zone

Your insulin delivery time zone is the time displayed in the Omnipod 5 App and only changes when you change it yourself. This is the time zone that your insulin delivery is based on. When you have the Automatic Time Zone setting ON, the Omnipod 5 App detects when your device time zone and insulin delivery time zone do not match and will notify you. For example, when you travel outside of the country, your Omnipod 5 App will ask you if you would like to update your insulin delivery time zone to your new local time.

You may want to change your insulin delivery time zone, for example, if you are preparing to travel to a new time zone.

To change your insulin delivery time zone:

1. In Manual Mode, navigate to: Menu button () > Settings > General > Insulin Delivery Time Zone
2. If you have an active Pod, tap PAUSE INSULIN and tap YES.
3. Select the desired time zone and tap SAVE and then tap CONFIRM.
4. Tap YES to restart insulin delivery.

Language

To change your preferred language:

1. Navigate to: Menu button (☰) > Settings > General > Language.
2. Select the language you would like to use for your Omnipod 5 App.
3. Tap SAVE.

The screen will flash briefly. The App will relaunch in the selected language. Changing the language will NOT reset your settings, history or adaptivity.

Reset

Caution: DO NOT reset the Omnipod 5 App before checking with your healthcare provider. This will erase all of your settings, Adaptive Basal Rate and history, and require you to change your active Pod. Before resetting, make sure you have a current record of your settings and a new Pod with supplies to use when restarting the App.

If you need to reset the Omnipod 5 App on your Controller, which will clear all your settings and history, follow these steps.

1. Navigate to: Menu button (☰) > Settings > General > Reset.
2. If you have an active Pod, deactivate and remove your Pod.

Note: While a Pod will continue delivering insulin into your body after an App reset, you will not be able to reconnect to this Pod to deliver a bolus or deactivate it later. Remove it and be ready to activate a new Pod.
3. Tap Clear all data.
4. Tap CONFIRM.
5. You will need to complete first-time setup again. Follow the steps in Chapter 4 to set up your Omnipod 5 App.

10.2 Reminder Settings

Caution: AVOID setting your Controller to Silent, Vibrate or any other setting that prevents you from hearing alarms and notifications from your Omnipod 5 App. If you do not hear alarms and notifications from your Controller, you might not make the changes you need to make to your insulin therapy in a timely manner. Your Pod will still sound, and you will be able to see the Alarm or Notification displayed on the Omnipod 5 App. See “13.3 Sounds and Vibrations” on page 153 to learn how to manage sounds and vibrations.

10 Changing Settings

Reminder notifications bring attention to various diabetes management actions you may want to take (see “13.11 Reminder Notifications List” on page 181 and “13.2 Alarms and Notifications Screen” on page 152).

Pod Expiry

The Pod Expiry Reminder tells you when the Pod is nearing its expiry so you can plan to change your Pod at a convenient time. You can set this notification to appear from 1 to 24 hours before the Pod expires. At the selected time, the Pod beeps. The Omnipod 5 App displays a message and the Controller beeps/vibrates.

To set the timing of the Pod Expiry Reminder:

1. Navigate to: Menu button () > Settings > Reminders > Pod expiry.
2. Tap the Pod Expiry field and select how long before your Pod expires that you would like to be notified.
3. Tap SAVE.

Low Pod Insulin

An Advisory Alarm from the Pod and Omnipod 5 App sounds when the insulin level in your Pod drops below the low Pod insulin setting. This setting can range from 10 to 50 units.

To set the insulin level for the Low Pod Insulin Advisory Alarm:

1. Navigate to: Menu button () > Settings > Reminders > Low Pod Insulin.
2. Tap the Low Pod Insulin field and select the level of Pod insulin at which you would like to be notified.
3. Tap SAVE.

Pod Shut-Off

Warning: You must use the Omnipod 5 App within 15 minutes of the onset of the Pod Shut-Off Advisory Alarm. If you do not respond to this alarm within this time, the Omnipod 5 App and Pod sound a Hazard Alarm and your Pod stops delivering insulin which can lead to hyperglycaemia.

If the Pod Shut-Off feature is ON, the Pod automatically deactivates if you do not use the Omnipod 5 App within the defined time. Consult your healthcare provider prior to changing the Pod Shut-Off setting.

To enable or disable Pod Shut-Off:

1. Navigate to: Menu button (☰) > Settings > Reminders > Pod Shut-Off.
2. Tap the Pod Shut-Off toggle to enable or disable the Pod Shut-Off feature.
3. If Pod Shut-Off is enabled, tap the Inactivity Timer field and select the length of time for the countdown timer. This setting can range from 1 to 24 hours.

Example: If you choose 10 hours, you must wake up your Omnipod 5 App and unlock it at least once every 10 hours, day and night, to prevent the Pod Shut-Off alarm.

4. Tap SAVE.

Confidence Reminders

When confidence Reminders are ON, you will hear a tone at the start and end of each bolus, Extended Bolus or Temp Basal:

- The Omnipod 5 App beeps at the start.
- The Pod beeps at the end.

Confidence Reminders are especially useful when you are getting familiar with your Omnipod 5 System and want additional confirmation that an insulin delivery command went through. To turn confidence Reminders ON or OFF:

1. Navigate to: Menu button (☰) > Settings > Reminders.
2. Tap the Confidence Reminders toggle to turn confidence Reminders ON or OFF.

Note: You cannot turn OFF beeps that occur at the start of a Temp Basal set to deliver no (zero) insulin.

Programme Reminders

When programme Reminders are ON, the Pod beeps every 60 minutes while a Temp Basal or Extended Bolus is in progress. To turn programme Reminders ON or OFF:

1. Navigate to: Menu button (☰) > Settings > Reminders.
2. Scroll as needed and tap the Programme Reminders toggle to turn programme Reminders ON or OFF.

Note: You cannot turn OFF beeps that occur during a Temp Basal set to deliver no (zero) insulin.

10.3 Basal and Temp Basal Settings

The following sections describe how to change settings that control basal insulin delivery.

Note: These settings only apply when using Manual Mode.

Maximum Basal Rate

The Maximum Basal Rate defines an upper limit for any basal rate used in your Basal Programmes and Temp Basals during Manual Mode only. Consult your healthcare provider before changing this setting.

To change your Maximum Basal Rate:

1. Navigate to: Menu button (☰) > Settings > Basal & Temp Basal > Max Basal Rate.
2. Tap the Max Basal Rate field and enter the new value for your Maximum Basal Rate.
3. Tap SAVE.

Note: You cannot set a Maximum Basal Rate that is lower than the highest basal rate of an existing Basal Programme, Temp Basal or currently running Temp Basal.

Temp Basal

To turn ON or OFF the ability to set Temp Basals:

1. Navigate to: Menu button (☰) > Settings > Basal & Temp Basal.
2. To enable or disable the ability to set temporary basal rates (Temp Basals), tap the toggle ON or OFF.
3. To change between using per cent (%) or flat rate (U/hr) Temp Basals:
 - a. Tap Temp Basal.
 - b. Select the desired method for setting a Temp Basal:
 - Tap Per cent (%) to modify the Basal Programme in progress by a set percentage increase or decrease.
 - Tap Flat Rate (U/hr) to replace the Basal Programme in progress with a fixed basal rate for the specified duration.
 - c. Tap SAVE.

CHAPTER 11

Browsing Your History and Records

Contents

11.1 About Your Recent History and Past Records	132
11.2 Viewing the Sensor Graph	132
11.3 Sensor Graph States	133
11.4 History Information Overview	135
History Summary Section	136
11.5 Calculations for History Summaries	138
Glucose Summaries	138
Insulin Delivery Summaries	138
11.6 History Details Section	139
Glucose Details	140
Glucose Goal Range	140
Bolus Details	141
Immediate and Extended Boluses	141
Extended Bolus events	141
When the Pod has not confirmed a bolus delivery	142
Pod Details	142
Carbs Details	142
Basal Rate Details	143
Activity feature	143
Basal Programmes	143
Temp Basals	143
Basal rate at midnight	143
Insulin Paused and Started Details	143
Time Change Details	144
Automated Events (Auto Events)	144

11 Browsing Your History and Records

11.1 About Your Recent History and Past Records

The Omnipod 5 App can store 90 days of history records. Once the memory is full, new records begin to replace the oldest records. You can browse but not edit the information in your records.

Your records are displayed on:

- Sensor Graph (recent)
- History Detail screens, which show insulin, glucose, carbohydrate, Pod events and Auto Events
- History of alarms and notifications can be viewed on the Notification screen.

11.2 Viewing the Sensor Graph

The Sensor Graph can be viewed from the Home screen in both Manual Mode and Automated Mode.

To view the Sensor Graph:

- On the lower right part of the Home screen, tap VIEW.

To exit the Sensor Graph:

- Tap the (X) located in the top right corner of the graph.

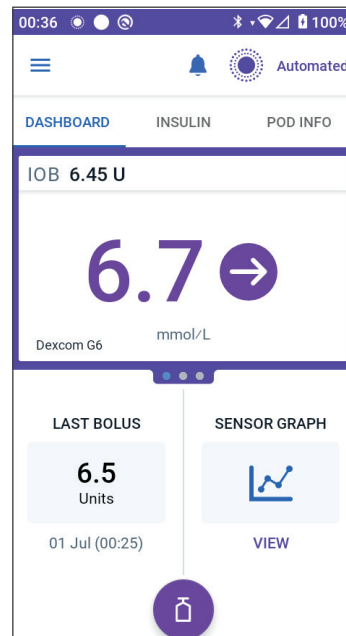

11.3 Sensor Graph States

When the Omnipod 5 System is in Manual Mode, the mode indicator is blue

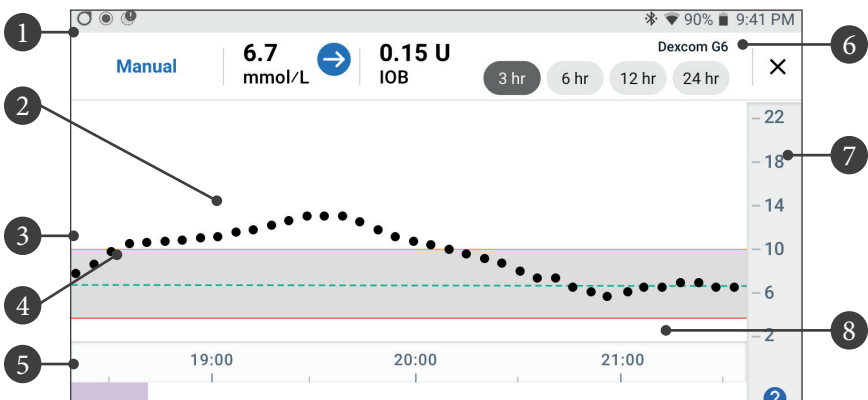

The graph shows your most recent sensor glucose values over the last 3, 6, 12, and 24 hours.

Note: You can tap the ? symbol in the lower right hand corner to see a Legend of symbols used in the Sensor graph.

1. **Current Status:** Your current sensor glucose value and trend arrow display, along with the current IOB
2. **Sensor glucose trend line:** Each dot on the graph represents a sensor glucose value. Plotted values are from 2.2–22.2 mmol/L (40–400 mg/dL).
3. **Glucose Goal Range:** This shaded area shows your Glucose Goal Range. The yellow line shows the Upper Limit, and the red line shows the Lower Limit that you set in settings.
4. **Target Glucose:** Dashed green line shows the Target Glucose that you set in settings. When the Activity feature is enabled, this value changes to 8.3 mmol/L (150 mg/dL).
5. **Event area:** The row below the graph shows:
 - Purple background for periods of time that Omnipod 5 was in Automated Mode.
 - Blank (white) background for the periods of time that Omnipod 5 was in Manual Mode, when there was no active Pod, or when there is no Pod communication.
 - Dark grey background when Omnipod 5 was delivering insulin in Automated Mode: Limited state.

11 Browsing Your History and Records

- A red line during the time that SmartAdjust technology paused insulin.
 - An orange line during time that the maximum amount of basal insulin was delivered by the Omnipod 5 System.
 - Bolus button at the time you started a bolus.
6. **View Selection:** Use the buttons to select 3-, 6-, 12- and 24-hour views.
 7. **Vertical axis:** Displays sensor glucose values
 8. **Time scale:** Displays hour and half-hour markings.

When the Omnipod 5 System is in Automated Mode, the mode indicator is purple.

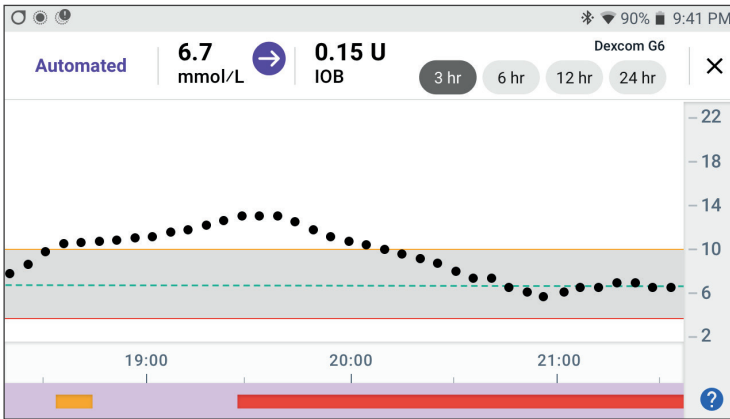

When the Omnipod 5 System is in Automated Mode: Limited state, the mode indicator is grey.

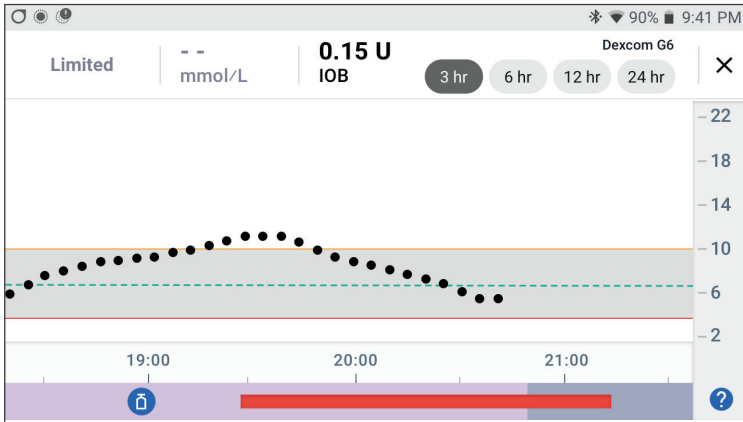

11.4 History Information Overview

You can access the history summary and detail information, and a list of automated events from the History Detail screen.

- Navigate to: Menu button (☰) > History Detail.

The screenshot shows the 'History' screen with the following data and annotations:

- Date:** Today, 03 August
- Summary Section:** - Tap AUTO EVENTS to see automated event details
- Glucose Summary:**
 - Average Sensor: 8.6 mmol/L
 - Sensor in Range: 74% (3.9 to 10.0 mmol/L)
 - Sensor Above: 24%
 - Sensor Below: 2%
- Insulin and Carb summary:**
 - Total Insulin: 28.9 U
 - Basal Insulin: 12.9 U
 - Bolus Insulin: 55 U
 - Total Carbs: 134 g
- Details section:** - Swipe to see expanded details

11 Browsing Your History and Records

Today's history records are displayed below the summary circles, beginning with the newest records on the top.

Note: Tap the "<" next to the date arrow to view an earlier day.

History Summary Section

The upper section of the History screens summarises the records for the day.



Summary item	Description
Row 1 - Sensor	
Average Sensor	Average of sensor glucose values for the day.
Sensor in Range	Percentage of sensor glucose values within your Glucose Goal Range.
Sensor Above	Percentage of sensor glucose values above your Glucose Goal Range.
Sensor Below	Percentage of sensor glucose values below your Glucose Goal Range.
Row 2 - Insulin & Carbs	
Total Insulin	Total insulin (basal + bolus) delivered for the day.
Basal Insulin	Percentage of the total insulin that was delivered as basal along with the number of units of basal insulin delivered. Basal insulin includes delivery based on your Basal Programme while in Manual Mode, and any automated deliveries received while in Automated Mode.
Bolus Insulin	Percentage of the total insulin that was delivered through bolus(es) along with the number of units of bolus insulin delivered.
Total Carbs	Sum of meal carbohydrates (in grams) that were used in bolus delivery calculations for the given day.

Note: Percentages may not add to 100 due to rounding.

For the summary of these calculations, see page 138.

When insulin delivery is unconfirmed

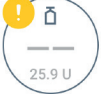
After delivering a bolus or basal dose of insulin, the Pod sends a confirmation to the Omnipod 5 App once completed. If a bolus, basal or total insulin delivery has not been confirmed, the following icons will display:

	<p>Bolus Insulin amount for the day is displayed as dashes (- -) along with a grey exclamation mark (!) if there are estimated bolus deliveries. The greyed-out value displayed can consist of both confirmed and scheduled amounts.</p>
	<p>Bolus Insulin amount for the day is displayed as dashes (- -) along with a yellow exclamation mark (!) when the Pod has been discarded before it could confirm insulin delivery.</p>
	<p>Basal Insulin amounts for the day are displayed as dashes (- -) along with a grey exclamation mark (!) when there are unconfirmed insulin deliveries, either bolus or basal.</p>
	<p>Basal Insulin amounts for the day are displayed as dashes (- -) along with a yellow exclamation mark (!) when the Pod has been discarded and there are lost insulin delivery records.</p>

11 Browsing Your History and Records

11.5 Calculations for History Summaries

This section lists the calculations for the summary data shown on the History screens.

Glucose Summaries

The calculations used for the glucose summaries include sensor glucose values (including HIGH and LOW values) and exclude manually entered readings.

Item	Calculation
Row 1	
Average Sensor	$= \frac{\text{Sum of all sensor glucose values}}{\text{Total number of sensor glucose values}}$ <p>Note: HIGH sensor glucose values are included as 22.2 and LOW sensor glucose values as 2.1.</p>
Sensor in Range	$= \frac{\text{Qty of sensor glucose values within the Glucose Goal Range}}{\text{Total number of sensor glucose values}} \times 100$
Sensor Above	$= \frac{\text{Qty of sensor glucose values above the Glucose Goal Range upper limit}}{\text{Total number of sensor glucose values}} \times 100$
Sensor Below	$= \frac{\text{Qty of sensor glucose values below the Glucose Goal Range lower limit}}{\text{Total number of sensor glucose values}} \times 100$

Insulin Delivery Summaries

Bolus insulin calculations include:

- SmartBolus Calculator boluses.
- Manual boluses.
- Any partial bolus amounts delivered from immediate or Extended Boluses that were cancelled that the Pod can confirm.

Basal insulin calculations include:

- Basal adjustments from SmartAdjust technology (Automated Mode).
- Basal Programmes (Manual Mode).
- ny adjustments for Temp Basals, pause periods or times without an active Pod.

When your Omnipod 5 System has not received updates from the Pod about confirmed insulin delivery, the insulin delivery calculations are estimates based on the scheduled insulin delivery.

Summary item	Calculation
Row 2	
Total Insulin	= Sum of basal and bolus insulin delivered
Basal Insulin	= Amount of basal insulin delivered in Manual Mode and all automated insulin deliveries in Automated Mode
Bolus Insulin	= Amount of bolus insulin delivered
Total Carbs	= Total grams of carbs entered into the SmartBolus Calculator

11.6 History Details Section

Scroll on the History screens to see the details section. The details section of the History screen shows individual records listed by time of day.

Tap a row with a down arrow to display more details. Tap again to hide the details.

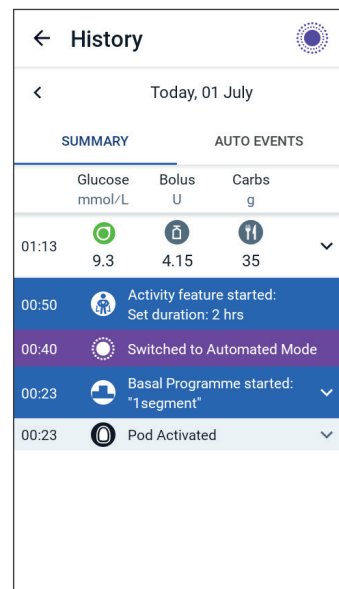



11 Browsing Your History and Records

Glucose Details

The icon displayed with a blood glucose reading indicates whether the glucose was in range.

The blood glucose icons are:

	BG entry
Above Glucose Goal Range	
Within Glucose Goal Range	
Below Glucose Goal Range	

The Dexcom G6 icon is: 

The FreeStyle Libre 2 Plus icon is: 

Glucose Goal Range

The goal of using the Omnipod 5 System is to keep your glucose within your Glucose Goal Range. You define this range by setting the upper and lower limits. The Sensor Graph and the Enter BG screen use the Glucose Goal Range to determine which glucose readings are within your goal and which are above or below your goal.



Note: The Glucose Goal Range does not impact insulin delivery.

To set the upper and lower limit of your Glucose Goal Range:

1. Navigate to: Menu button () > Settings > Glucose Goal Range.
2. Set the limits of the Glucose Goal Range:
 - a. Tap the Upper Limit field and enter the desired value.
 - b. Tap the Lower Limit field and enter the desired value.
3. Tap SAVE.

Bolus Details

The icon displayed with a bolus entry indicates whether the SmartBolus Calculator was used:

- The insulin bottle icon () indicates that the SmartBolus Calculator was used.
- The syringe icon () indicates a manual bolus was delivered.

Immediate and Extended Boluses

The bolus amount listed next to the Bolus button is the total of an immediate bolus plus any extended portion of the bolus. If you cancel an immediate or Extended Bolus, the amount listed is the confirmed amount delivered before cancellation.

Tapping a row with a bolus entry expands the record to show additional details about the bolus, including:

- Whether the bolus was calculated by the SmartBolus Calculator or it was a manual bolus.
- The VIEW BOLUS CALCULATIONS button if the SmartBolus Calculator was used. Tapping this button brings up a screen showing the calculation details and whether you made a manual adjustment to the calculated bolus.

You may need to scroll up or down to see all of the calculations. Tap CLOSE when done (see “18.1 The SmartBolus Calculator” on page 234 for details).

- The amount originally scheduled for delivery if you cancelled an immediate bolus.
- For an Extended Bolus, the amount delivered now and extended, and the percentage (%) of the meal bolus delivered now and extended.
- If a bolus is ongoing, unconfirmed or lost, how much of the bolus has been confirmed.

Extended Bolus events

 A Bolus button and banner indicate an Extended Bolus event:

- An Extended Bolus started banner marks the time when the immediate bolus finishes and the Extended Bolus starts. In addition to the start time of the bolus, the banner lists the number of units extended and the duration of the extension.

11 Browsing Your History and Records

- An Extended Bolus completed banner marks the end of the Extended Bolus.
- An Extended Bolus cancelled banner marks the cancellation of an Extended Bolus and states the confirmed amount of the bolus that was delivered before cancellation.

When the Pod has not confirmed a bolus delivery

After you confirm the amount of a bolus that you want to be delivered, a bolus instruction is sent to your Pod. When the Pod completes delivery, it sends a confirmation to the Omnipod 5 App that the bolus was delivered.



Before the Omnipod 5 App receives confirmation from the Pod that the bolus has been delivered, the Omnipod 5 App estimates the amount delivered. During this time, the History screens use a grey exclamation icon to indicate that the bolus is estimated.



In most cases, after the Controller and Pod are back in range, the Pod confirms the bolus delivery. However, in rare cases, the Pod is unable to confirm bolus delivery due to a communication error. If you tap the DISCARD POD option in this situation, the History screens use a yellow exclamation icon to mark the bolus as “unconfirmed.”

If a Pod is discarded with an unconfirmed bolus, the basal and total insulin amounts for that day are also marked as unconfirmed with dashes and a yellow exclamation mark. The listed bolus amount includes the amount that was scheduled for delivery up until the Pod was discarded.

Note: If you have an unconfirmed bolus, the SmartBolus Calculator is disabled for the Duration of Insulin Action.

Pod Details



A Pod icon and banner mark the activation and deactivation (or discarding) of each Pod. Tapping a Pod banner displays the Pod’s lot number and sequence number.

Carbs Details

A carbs icon () is displayed next to carbohydrate entries used by the SmartBolus Calculator.

Basal Rate Details

Activity feature



In Automated Mode, an Activity icon and banner indicate the start, end or cancellation of the Activity feature.

Basal Programmes



A Basal Programme icon and banner indicate the start of a Basal Programme and the restart of a Basal Programme at the end of a Temp Basal or insulin pause period.

Temp Basals



In Manual Mode, a Temp Basal icon and banner indicate the start, end or cancellation of a Temp Basal.

If a Temp Basal was defined as a percentage (%) of the Basal Programme in progress, the banner displays the per cent increase or decrease as well as the duration. If a Temp Basal was defined as a flat basal rate (U/hr), the banner displays the Temp Basal rate and the duration.

If a Temp Basal Preset was used, the banner displays the name of the preset.

Tapping a Temp Basal started banner displays a graph of basal rates associated with each time segment.

If a Temp Basal was cancelled, the Temp Basal started banner contains the scheduled duration and the Temp Basal cancelled banner contains the actual duration.

Basal rate at midnight

The first entry for each day is a banner displaying the status of the basal insulin delivery at midnight. If a Basal Programme, Temp Basal or use of the Activity feature was carried over from the day before, the banner indicates that this is a continued programme. If insulin was paused at midnight, the banner states this.

Insulin Paused and Started Details



An Insulin Delivery Paused icon and banner indicate the time an insulin paused period began.



An Insulin Delivery Started icon and banner indicate the time insulin delivery was restarted.

11 Browsing Your History and Records

Time Change Details

A Time zone changed banner appears if you change your insulin delivery time zone.

After the time zone change has occurred, new history entries will reflect your new time zone.

Note: History entries recorded before your time zone changed will show in your prior time zone.

Automated Events (Auto Events)

Tap AUTO EVENTS on the history screen to display the amount of insulin delivered at each 5-minute period while in Automated Mode.

A system mode icon and banner show the time the system switched to Automated Mode or to Manual Mode.

This tab shows all automated insulin, both your baseline Adaptive Basal Rate and any adjustment up or down due to your sensor glucose value, trend, and 60-minute prediction.

Note: Your sensor glucose value informs how much insulin the System will deliver in the next 5-minute time period. For example, if your sensor glucose value at 11:00 dropped to 3.2 mmol/L (58 mg/dL), SmartAdjust technology will not deliver a microbolus at 11:05. Your Auto Events tab will display 0 U at 11:05.

Today, 20 June		
SUMMARY		AUTO EVENTS
	Sensor mmol/L	Insulin Amount U
16:16	Switched to Manual Mode	
16:15	7.5	0.15
16:10	7.6	0.1
16:05	7.4	0.05
16:00	6.8	0.05
15:55	6.4	0
15:50	6.2	0
15:45	5.6	0.1
15:40	5.3	0.15
15:35	5.1	0.1
15:30	Switched to Automated Mode	

CHAPTER 12

Managing Software Updates

Contents

12.1 Insulet-provided Controller	146
Operating System (OS) Update.....	147
Omnipod 5 App Update	148

12.1 Insulet-provided Controller

When connected to a network, the Omnipod 5 Controller offers over-the-air updates when a software update is available. There are two types of updates for the Omnipod 5 Controller: OS (Operating System) updates and Omnipod 5 App updates. OS update refers to updating the operating system of the Controller. Omnipod 5 App update refers to updating the Omnipod 5 App on the Controller. When an update is available, you will receive a notification prompting you to update.

Note: You will not be able to navigate in the Omnipod 5 App during an Omnipod 5 update; however, your insulin therapy will not be impacted. The Pod continues delivering insulin and will re-establish connection with the Omnipod 5 App once the update is complete.

Note: The Controller must be connected to a network to receive over-the-air updates. If you turn Flight Mode ON, you may miss important updates.

Note: All updates on the Controller that are considered optional require a Wi-Fi connection.

Note: If you have an immediate bolus in progress, software updates will be delayed until the bolus is complete.

Caution: ALWAYS make sure your battery has adequate charge prior to installing a software update.

Caution: Connect ONLY to trusted Wi-Fi networks with your Controller. AVOID connecting to public Wi-Fi networks, such as those found in airports, coffee shops, etc., as these networks are not secure and could result in exposing your Controller to malware. DO NOT connect to public Wi-Fi networks during first-time setup of your Omnipod 5 System.

Operating System (OS) Update

Operating System (OS) updates may be either “optional” or “required”. Required updates require you to perform the update immediately before you can use the Omnipod 5 App. Optional updates may be postponed to a later time.

To download and install an OS update on the Controller:

1. Ensure your Controller is currently charging or the battery is charged to above 40%.

Note: If your Controller is currently charging, the battery must be above 20%.

2. Tap Update Now.

The Omnipod 5 Controller begins to update.

Once the update is complete, you will see a confirmation screen.

If the update is not considered required, you may select Not Now to delay the update to a later time; however, it is recommended that you update the OS as soon as the update is available. If you choose to postpone an optional update, you can manually update at any time. After 72 hours have passed, you will receive a notification every 24 hours reminding you to update. To manually update the operating system of the Controller:

1. Ensure your Controller is currently charging or the battery is charged to above 40%.

Note: If your Controller is currently charging, the battery must be above 20%.

2. Go to the Home screen.
3. Tap the notification bell.
4. Tap the update notification.
5. Tap Update Now.

Once the update is complete, a confirmation screen displays to inform you that the update was completed successfully.

Omnipod 5 App Update

Omnipod 5 App updates may be either “optional” or “required”. Required updates require you to perform the update immediately before proceeding to use the Controller. Optional updates may be postponed to a later time.

To download and install an Omnipod 5 App update on the Controller:

1. Ensure your battery is charged to above 15%.
2. Select **Update Now**.

After the update is complete, a confirmation screen displays to inform you that the update was completed successfully.

If the update is not considered required, you may select **Not Now** to delay the update to a later time; however, it is recommended that you update the Omnipod 5 App as soon as the update is available. If you choose to postpone an optional update to a later time, you can manually update the Omnipod 5 App at any time. After 72 hours have passed, you will receive a notification every 24 hours reminding you to update your Omnipod 5 App.

To manually update your Omnipod 5 App:

1. Ensure your battery is charged to above 15%.
2. Go to the Home screen.
3. Tap the notification bell.
4. Tap the update notification.
5. Tap **Update Now**.

Once the update is complete, a confirmation screen displays to inform you that the update was completed successfully.





CHAPTER 13

Alarms, Action and Reminder Notifications

Contents

13.1 Types of Alarms and Notifications	151
13.2 Alarms and Notifications Screen	152
13.3 Sounds and Vibrations	153
13.4 Informational Sounds and Vibrations	154
Confidence reminders	154
Programme reminders.....	154
Basal Programme changes	155
Cancelling temp basals and boluses	155
13.5 Responding to Alarms	156
Diagnostics.....	157
13.6 Hazard Alarm List	158
⚠ Blockage Detected	158
⚠ Omnipod 5 App Error	159
⚠ Omnipod 5 Memory Corruption.....	160
⚠ Pod Error.....	161
⚠ Pod Expired.....	162
⚠ Pod Out of Insulin	163
⚠ Pod Shut-Off.....	164
⚠ System Error	165
13.7 Advisory Alarm List	166
⚠ Low Pod Insulin.....	166
⚠ Pod Expired.....	167
⚠ Pod Shut-Off.....	168
⚠ Start Insulin	169
⚠ Urgent Low Glucose.....	170
13.8 Action Item Notification List	171
🚫 App Use Blocked	171
🌐 Connect to a Wireless Network	172
🕒 Daylight Saving Time Change.....	173

13 Alarms, Action and Reminder Notifications

-  Omnipod 5 Error174
-  Update Omnipod 5 - App No Longer Supported175
-  Update Omnipod 5 - Software Update176
-  Update OS177
-  Update Time Zone.....178

13.9 Silencing Unresolved Alarms. 179

- Pod Alarm179
- Controller Alarm179

13.10 Responding to Reminder Notifications 180



13.11 Reminder Notifications List 181

13.1 Types of Alarms and Notifications

Warning: ALWAYS contact Customer Care if your Omnipod 5 System Controller is damaged and not working properly. If a Controller replacement is needed, ALWAYS consult with your healthcare provider to get instructions on using other backup insulin delivery methods, like insulin injections. Be sure to check your glucose frequently.

Caution: AVOID setting your Controller to Silent, Vibrate or any other setting that prevents you from hearing alarms and notifications from your Omnipod 5 App. If you do not hear alarms and notifications from your Controller, you might not make the changes you need to make to your insulin therapy in a timely manner. Your Pod will still sound, and you will be able to see the Alarm or Notification displayed on the Omnipod 5 App. See “13.3 Sounds and Vibrations” on page 153 to learn how to manage sounds and vibrations.

The Omnipod 5 System generates the following types of alarms and notifications:

- **Alarms:**
 -  **Hazard Alarms** are high-priority alarms that indicate a serious problem has occurred, and you may need to remove your Pod. Hazard Alarms will repeat every 15 minutes until acknowledged. The audible alarm on the Pod will continue until acknowledged in the Omnipod 5 App. See “13.6 Hazard Alarm List” on page 158.
 - In general, only one Hazard Alarm can occur at a time. In the unlikely event that a Pod and Omnipod 5 App Hazard Alarm occur simultaneously, the Hazard Alarm that most recently occurred will be displayed first on the Omnipod 5 App. Any Pod Hazard Alarms will be sounded on the Pod.
 -  **Advisory Alarms** are low-priority alarms that indicate that a situation exists that needs your attention. Advisory Alarms will repeat every 15 minutes until acknowledged (see Alarm tables for additional details) and continue on the Pod until acknowledged in the Omnipod 5 App. See “13.7 Advisory Alarm List” on page 166.
- **Notifications:**
 - **Action Item notifications** are for technical System tasks that need your attention. See page 152.
 -  **Reminder notifications** remind you about a diabetes management action that you may want to perform. See “13.11 Reminder Notifications List” on page 181.

13 Alarms, Action and Reminder Notifications

- **Communication error** messages display when the Omnipod 5 App is unable to communicate with the Pod. See “26.5 Pod Communication Issues – “Try Again”” on page 374.

For how to view the alarms and notifications history, see page 152.

For Dexcom G6 alarm information, see the *Dexcom G6 CGM System Instructions for Use*.

For FreeStyle Libre 2 Plus Sensor alarm information, see “20.5 FreeStyle Libre 2 Plus Sensor Communication and Problem Messages” on page 283.

13.2 Alarms and Notifications Screen

To review past alarms and notifications:

1. Tap Menu button (☰) > Notifications.
Messages from today are displayed first, with newest at the top of the screen and oldest at the bottom of the screen.
2. To display a specific date range, tap FILTER BY DATE.
 - a. Tap the starting date on the calendar.
Note: Tap the “<” arrow to view an earlier month.
 - b. Tap END at the top of the screen.
 - c. Tap the ending date for the date range.
 - d. Tap OK.
3. When finished, tap the back arrow to exit (←). Unread notifications have coloured icons described in “13.1 Types of Alarms and Notifications” on page 151.

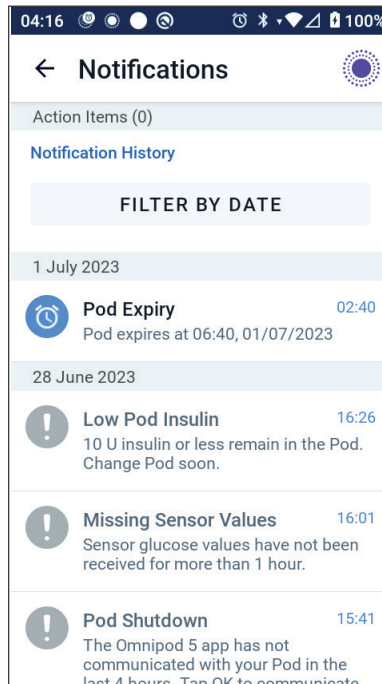

Note: When a notification has been displayed on this screen, and you have exited by tapping the back arrow (←), the icon for those notifications will be grey the next time you view this screen.

13.3 Sounds and Vibrations

The Omnipod 5 System uses sounds and vibrations to attract your attention to an alarm or notification.

Caution: AVOID setting your Controller to Silent, Vibrate or any other setting that prevents you from hearing alarms and notifications from your Omnipod 5 App. If you do not hear alarms and notifications from your Controller, you might not make the changes you need to make to your insulin therapy in a timely manner. Your Pod will still sound, and you will be able to see the Alarm or Notification displayed on the Omnipod 5 App.

Tip: To test the sounds and vibrations, see “Check alarms” on page 157.

Pod alarms

The Pod sounds a tone when it detects a problem that can affect insulin delivery.



- Pod Hazard Alarms are continuous tones broken up periodically by a set of beeps.
- Pod Advisory Alarms and notifications are intermittent beeps, which periodically repeat until you acknowledge them.

Omnipod 5 App alarms

Omnipod 5 App alarm sounds are dependent on your Controller sound settings, for example, silent or vibrate setting.

The Sound/vibrate button on your Controller

The Sound/vibrate button, located on the upper right side of the Controller, controls whether all notifications use vibrations or sounds.

- To turn vibrations ON, press and hold the lower end of the Sound/vibrate button until the vibrate icon () appears on the screen.
- To turn sound ON, press the upper end of the Sound/vibrate button until the sound icon () appears on the screen.
- To increase or decrease the volume, press the upper or lower end of the Sound/vibrate button. On the screen, you can also move the volume indicator to the left to decrease the volume and move it to the right to increase the volume.

13 Alarms, Action and Reminder Notifications

13.4 Informational Sounds and Vibrations

Caution: AVOID setting your Controller to Silent, Vibrate or any other setting that prevents you from hearing alarms and notifications from your Omnipod 5 App. If you do not hear alarms and notifications from your Controller, you might not make the changes you need to make to your insulin therapy in a timely manner. Your Pod will still sound, and you will be able see the Alarm or Notification displayed on the Omnipod 5 App. See “13.3 Sounds and Vibrations” on page 153 to learn how to manage sounds and vibrations.

The Pod and the Omnipod 5 App can provide informational sounds (tones, beeps) or vibrations to let you know that normal Activity between the Pod and the Omnipod 5 App is occurring as expected. See the tables below for descriptions of informational sounds you will encounter during use.

Confidence reminders

Cause	Omnipod 5 App	Pod
Tones or vibrations let you know that your Temp Basals and boluses are working as expected. These Reminders are ON by default. To turn them ON or OFF, see “Confidence Reminders” on page 129.	Tone/vibration at the start of a Temp Basal, bolus or Extended Bolus.	Beeps once at the end of a Temp Basal, bolus or Extended Bolus.

Note: Confidence Reminders and programme Reminders are turned on by default. These Reminders cause the Omnipod 5 App or Pod to beep at the beginning and end of boluses and Temp Basals, and also once an hour during an Extended Bolus or Temp Basal. For more information, see “Confidence Reminders” on page 129.

Programme reminders

Cause	Omnipod 5 App	Pod
Beeps remind you that you have a Temp Basal or Extended Bolus running. These Reminders are ON by default. To turn them ON or OFF, see page 129.	No tone/vibration	Beeps once every 60 minutes while a Temp Basal or Extended Bolus is running.

Basal Programme changes

Cause	Omnipod 5 App	Pod
Tones or vibrations inform you of changes to your Basal Programme. You cannot turn these OFF.	Tone/vibration when a Basal Programme is activated, edited, paused or started.	Beeps once every 15 minutes after the pause period has ended.

Cancelling temp basals and boluses

Cause	Omnipod 5 App	Pod
Tone informs you that the Temp Basal or bolus has been successfully cancelled. You cannot turn these OFF.	No tone/vibration	Beeps once when you cancel a Temp Basal, bolus or Extended Bolus.

Pod activation/Pod deactivation

Cause	Omnipod 5 App	Pod
Tones or vibrations occur at various times during the Pod activation process to indicate progress. You cannot turn these OFF.	Tone/vibration when the Pod and Omnipod 5 App are successfully paired. Sounds tone/vibrates twice when the Pod is successfully deactivated.	Beeps twice when it has been filled with the minimum amount of insulin needed for activation (see page 82). Beginning 10 minutes after the Pod is filled with insulin, beeps every five minutes until insulin delivery has started.

13.5 Responding to Alarms

Caution: AVOID leaving your Controller in a place that would prevent you from hearing alarms and notifications from your Omnipod 5 App. Delivery of insulin in Manual Mode or Automated Mode continues as programmed if you move away from your Controller.

Caution: AVOID setting your Controller to Silent, Vibrate or any other setting that prevents you from hearing alarms and notifications from your Omnipod 5 App. If you do not hear alarms and notifications from your Controller, you might not make the changes you need to make to your insulin therapy in a timely manner. Your Pod will still sound, and you will be able to see the Alarm or Notification displayed on the Omnipod 5 App. See “13.3 Sounds and Vibrations” on page 153 to learn how to manage sounds and vibrations.

To respond to a Hazard Alarm or Advisory Alarm:

1. Wake up your Controller. The Lock screen shows an alarm message along with the Hazard Alarm (⚠️) icon or Advisory Alarm (🟡) icon.
2. After unlocking your Omnipod 5 App, follow the on-screen instructions or see the individual alarm details starting on page 157.

Note: You can use your Omnipod 5 System even if you do not address an Advisory Alarm immediately. However, you must acknowledge a Hazard Alarm before you can use your Omnipod 5 System.

Tip: If you follow the Omnipod 5 App’s instructions and are still not able to silence a Hazard Alarm, see “13.9 Silencing Unresolved Alarms” on page 179.

Note: If a Temp Basal or Extended Bolus is running when a Pod Hazard Alarm occurs, the Omnipod 5 App informs you that it was cancelled.

Timing of Pod Alarms on the Omnipod 5 App

If the Pod is sounding a Hazard Alarm, the Pod sends a signal to your Omnipod 5 App.

- If the Controller is in range and awake within 25 seconds of the Pod’s initial alarm sound, your Omnipod 5 App also sounds an alarm and displays the alarm message.
- If the Controller is in range but asleep, there could be a delay of up to 6 minutes between when the Pod sounds the alarm and when your Omnipod 5 App sounds the alarm.
- If the Controller is out of range of the Pod, your Omnipod 5 App cannot receive any communication from the Pod. Therefore, if you hear a Pod alarm or notification, bring your Controller in range of the Pod and wake up your Omnipod 5 App. Within 25 seconds, your Omnipod 5 App sounds the alarm and displays the alarm message.

Diagnostics

Warning: DO NOT continue using an activated Pod that fails to beep during a diagnostic test. The Pod should be changed immediately. If the Omnipod 5 App fails to beep during a diagnostic test, contact Customer Care immediately. Continuing to use the Omnipod 5 System in these situations could put your health and safety at risk.

Check alarms

Before you begin, switch to Manual Mode if currently using Automated Mode. See “22.2 Switching from Automated Mode to Manual Mode” on page 320.

Note: Your Controller sound settings must be ON to hear a tone on the Omnipod 5 App.

To verify that your Omnipod 5 App and Pod’s alarms and vibration functions are working properly, test them as follows:

1. Navigate to: Menu button () > Settings > General > Check Alarms.
2. If you have an active Pod, tap PAUSE INSULIN and tap YES.
3. Tap CHECK ALARMS to initiate the alarm check.
4. Listen and feel: The Controller beeps and vibrates three times. If you are wearing a Pod, the Pod beeps several times and sounds the alarm tone for several seconds.
5. If the Pod did not beep, tap NO. Then either tap CHECK AGAIN to retry testing the alarms, or tap DONE and change your Pod.
6. If the Omnipod 5 System alarms did not sound, tap NO. Then either tap CHECK AGAIN to retry testing the alarms or contact Customer Care.
7. If the beeps and vibrations worked properly, tap YES. If you paused insulin to check the alarms, tap YES to start insulin delivery.

13 Alarms, Action and Reminder Notifications



13.6 Hazard Alarm List

Warning: ALWAYS respond to Hazard Alarms as soon as they occur. Pod Hazard Alarms indicate that insulin delivery has stopped. Failure to respond to a Hazard Alarm could result in under-delivery of insulin, which can lead to hyperglycaemia.



Hazard Alarms make you aware of serious situations. Always respond to a Hazard Alarm immediately. Some alarm messages give you a unique number called a reference number. Give that number to Customer Care if you call about that alarm.

Blockage Detected



Warning: ALWAYS monitor your glucose and follow your healthcare provider's treatment guidelines when you stop receiving insulin due to a blockage (occlusion). Not taking action promptly could result in under-delivery of insulin, which can lead to hyperglycaemia or diabetic ketoacidosis (DKA).

Screen Alert	Description
<p>Omnipod 5 App:</p> <div data-bbox="134 906 443 1340"><p>Blockage Detected</p><p>Insulin delivery stopped. Change Pod now.</p><p>Check your glucose.</p><p>Ref: 17-00069-00351-020</p><p>OK, DEACTIVATE POD NOW</p></div>	<p>Why it occurs: A blockage (occlusion) was detected from the blocked cannula, a Pod malfunction, or from using old or inactive insulin, which has stopped insulin delivery.</p> <p>Pod sound: Continuous tone</p> <p>Controller sound and vibration:</p> <ul style="list-style-type: none">• 30-second tone• 30-second vibration• Vibration and tone repeat every 15 minutes until acknowledged <p>What to do:</p> <ol style="list-style-type: none">1. Tap OK, DEACTIVATE POD NOW.2. Change your Pod.3. Check your blood glucose.
<p>Lock Screen:</p> <div data-bbox="126 1377 475 1483"><p>Blockage Detected Insulin delivery stopped. Change P. </p></div>	

Omnipod 5 App Error



Screen Alert	Description
<p>Omnipod 5 App:</p> <div data-bbox="238 340 536 765" style="border: 1px solid black; padding: 10px;"> <p style="text-align: center;">Omnipod 5 App error</p> <div style="text-align: center;">  </div> <hr/> <p>If this happens again, contact Customer Care.</p> <p>Tap OK to continue.</p> <p>Ref: 05-50069-00351-008</p> <div style="text-align: center; margin-top: 10px;"> <div style="background-color: #4a5568; color: white; padding: 5px 15px; border-radius: 5px; display: inline-block;">OK</div> </div> </div>	<p>Why it occurs: An unexpected error is detected in the Omnipod 5 App.</p> <p>Note: If your Omnipod App stops and restarts on its own, you may notice the App flashing white before this screen appears.</p> <p>Pod sound: None</p> <p>Controller sound and vibration:</p> <ul style="list-style-type: none"> • 30-second tone • 30-second vibration • Vibration and tone repeat every 15 minutes until acknowledged
<p>Lock Screen:</p> <div data-bbox="223 878 570 956" style="border: 1px solid black; padding: 5px;"> <p>Omnipod 5 App error An error has occurred. Check the O.. </p> </div>	<p>What to do:</p> <ol style="list-style-type: none"> 1. Tap OK to acknowledge or silence the alarm. <p>Note: Depending on the cause of this error, the Controller may restart after you tap OK. Whether or not that happens, continue with the following steps.</p> <ol style="list-style-type: none"> 2. Contact Customer Care immediately. 3. Check your blood glucose.

⚠ Omnipod 5 Memory Corruption

Screen Alert	Description
<p>Omnipod 5 App:</p> <div data-bbox="151 328 414 747" style="border: 1px solid black; padding: 10px;"> <p>Omnipod 5 App memory corruption</p>  <p>Your Pod is no longer connected to the app. Remove Pod now.</p> <p>Tap OK to reset the Omnipod 5 app and delete all user settings.</p> <p>Ref: 19-00069-00351-034</p> <p style="text-align: center; background-color: #4a5568; color: white; padding: 5px;">OK</p> </div>	<p>Why it occurs: An unexpected error is detected in the Omnipod 5 App.</p> <p>Pod sound: None</p> <p>Controller sound and vibration:</p> <ul style="list-style-type: none"> • 30-second tone • 30-second vibration • Vibration and tone repeat every 15 minutes until acknowledged
<p>Lock Screen:</p> <div data-bbox="130 830 458 910" style="border: 1px solid black; padding: 5px;"> <p>Omnipod 5 App memory corruption Remove Pod now. Check the Omnipod.. </p> </div>	<p>What to do:</p> <ol style="list-style-type: none"> 1. Tap OK to acknowledge the alarm and reset the Omnipod 5 App. 2. Remove your Pod. 3. Contact Customer Care immediately. 4. Check your blood glucose.

Pod Error

Caution: ALWAYS activate a new Pod in a timely manner. Waiting too long between Pod changes could result in under-delivery of insulin, which can lead to hyperglycaemia. If another Pod is not available, use a different insulin delivery method.

Screen Alert	Description
<p>Omnipod 5 App:</p> <div data-bbox="246 490 532 855" style="border: 1px solid black; padding: 10px; text-align: center;"> <p>Pod Error</p>  <p>Insulin delivery stopped. Change Pod now.</p> <p>Ref: 19-00069-00351-034</p> <p>OK, DEACTIVATE POD NOW</p> </div>	<p>Why it occurs: The Pod detects an unexpected error and insulin delivery has stopped.</p> <p>Pod sound: Continuous tone</p> <p>Controller sound and vibration:</p> <ul style="list-style-type: none"> • 30-second tone • 30-second vibration • Vibration and tone repeat every 15 minutes until acknowledged
<p>Lock Screen:</p> <div data-bbox="226 993 562 1068" style="border: 1px solid black; padding: 5px;"> <p>Pod Error Insulin delivery stopped. Change P. </p> </div>	<p>What to do:</p> <ol style="list-style-type: none"> 1. Tap OK, DEACTIVATE POD NOW. 2. Change your Pod. 3. Check your blood glucose.



Pod Expired

Caution: ALWAYS activate a new Pod in a timely manner. Waiting too long between Pod changes could result in under-delivery of insulin, which can lead to hyperglycaemia. If another Pod is not available, use a different insulin delivery method.

Screen Alert	Description
<p>Omnipod 5 App:</p> <div data-bbox="154 495 443 866" style="border: 1px solid black; padding: 10px; text-align: center;"> <p>Pod Expired:</p>  <p>Insulin delivery stopped. Change Pod now.</p> <p>Ref: 16-00069-00351-028</p> <p>OK, DEACTIVATE POD NOW</p> </div>	

Pod Out of Insulin



Caution: ALWAYS activate a new Pod in a timely manner. Waiting too long between Pod changes could result in under-delivery of insulin, which can lead to hyperglycaemia. If another Pod is not available, use a different insulin delivery method.

Screen Alert	Description
<p>Omnipod 5 App:</p> <div style="border: 1px solid black; padding: 10px; text-align: center;"> <p>Pod Out of Insulin</p>  <p>Pod empty; no insulin left in Pod. Insulin delivery stopped.</p> <p>Change Pod now.</p> <p>Ref: 14-00069-00351-024</p> <p>OK, DEACTIVATE POD NOW</p> </div>	<p>Why it occurs: The Pod's insulin reservoir is empty and insulin delivery has stopped.</p> <p>Pod sound: Continuous tone</p> <p>Controller sound and vibration:</p> <ul style="list-style-type: none"> • 30-second tone • 30-second vibration • Vibration and tone repeat every 15 minutes until acknowledged
<p>Lock Screen:</p> <div style="border: 1px solid black; padding: 5px;"> <p>Pod Out of Insulin Insulin delivery stopped. Change P. </p> </div>	<p>What to do:</p> <ol style="list-style-type: none"> 1. Tap OK, DEACTIVATE POD NOW. 2. Change your Pod. 3. Check your blood glucose.



13 Alarms, Action and Reminder Notifications

⚠ Pod Shut-Off

Caution: ALWAYS activate a new Pod in a timely manner. Waiting too long between Pod changes could result in under-delivery of insulin, which can lead to hyperglycaemia. If another Pod is not available, use a different insulin delivery method.

Screen Alert	Description
<p>Omnipod 5 App:</p> <div data-bbox="170 481 440 883" style="border: 1px solid black; padding: 10px; text-align: center;"> <p>Pod Shutdown</p>  <p>Insulin delivery stopped. The Omnipod 5 app has not communicated with your Pod in the last 4 hours. To start insulin delivery, change your Pod.</p> <p>Ref: 15-00069-00351-041</p> <p>OK, DEACTIVATE POD NOW</p> </div>	<p>Why it occurs: The Pod has stopped delivering insulin because you have set a Pod Shut-Off time and you did not respond to the Pod Shut-Off Advisory Alarm.</p> <p>Pod sound: Continuous tone</p> <p>Controller sound and vibration:</p> <ul style="list-style-type: none"> • 30-second tone • 30-second vibration • Vibration and tone repeat every 15 minutes until acknowledged
<p>Lock Screen:</p> <div data-bbox="133 1028 464 1104" style="border: 1px solid black; padding: 5px;"> <p>Pod Shutdown Insulin delivery stopped. The Omni.. </p> </div>	<p>What to do:</p> <ol style="list-style-type: none"> 1. Tap OK, DEACTIVATE POD NOW. 2. Change your Pod. 3. Check your blood glucose. <p>Note: To change the Pod Shut-Off setting, see “Pod Shut-Off” on page 128.</p>

System Error

Screen Alert	Description
<p>Omnipod 5 App:</p> <div data-bbox="260 313 549 769" style="border: 1px solid black; padding: 10px;"> <p style="text-align: center;">System Error</p> <div style="text-align: center;">  </div> <hr/> <p>Your System may not be working as it should. Remove Pod now. If this happens again, contact Customer Care.</p> <p>Tap OK to continue.</p> <p>Ref: 50-50069-00351-006</p> <div style="text-align: center; margin-top: 10px;"> OK, DEACTIVATE POD NOW </div> </div>	<p>Why it occurs: An unexpected error is detected in the Pod or the Omnipod 5 App.</p> <p>Pod sound: None</p> <p>Controller sound and vibration:</p> <ul style="list-style-type: none"> • 30-second tone • 30-second vibration • Vibration and tone repeat every 15 minutes until acknowledged <p>What to do:</p> <ol style="list-style-type: none"> 1. Tap OK to acknowledge the alarm. 2. Remove your Pod. 3. Contact Customer Care immediately. 4. Check your blood glucose.
<p>Lock Screen:</p> <div data-bbox="226 853 552 931" style="border: 1px solid gray; padding: 5px;"> <p>System Error Remove Pod now. Check the Omnipod.. </p> </div>	

13.7 Advisory Alarm List

Caution: ALWAYS respond to Pod Expired, Low Pod Insulin, and Pod Shut-Off Advisory Alarms when they occur. These alarms escalate to Hazard Alarms if no action is taken. When Hazard Alarms occur, insulin delivery stops.

Advisory Alarms inform you of a situation that needs your attention in the near future.

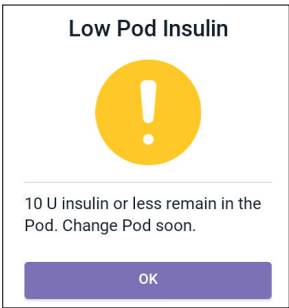
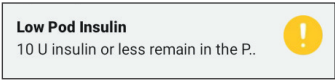

! Low Pod Insulin

Screen Alert	Description
<p>Omnipod 5 App:</p> 	<p>Why it occurs: The amount of insulin in the Pod is below the value specified in your settings.</p> <p>Pod sound:</p> <ul style="list-style-type: none"> • 8-beep tone pattern • Tone pattern sounds once every 3 minutes for 60 minutes <p>Controller sound and vibration:</p> <ul style="list-style-type: none"> • 3-second tone • 3-second vibration • Vibration and tone repeat every 15 minutes until acknowledged
<p>Lock Screen:</p> 	<p>What to do:</p> <ol style="list-style-type: none"> 1. Tap OK. 2. Change your Pod.
<p>Note: This escalates to the Pod Out of Insulin Hazard Alarm if ignored.</p> <p>Note: To change this value, see “Low Pod Insulin” on page 128.</p>	

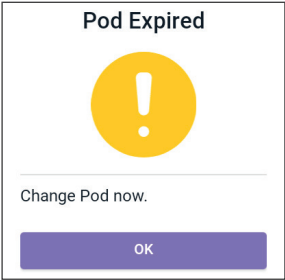
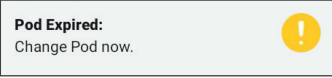
! Pod Expired

Screen Alert	Description
<p>Omnipod 5 App:</p> 	<p>Why it occurs: Your Pod will stop delivering insulin soon.</p> <p>Pod sound:</p> <ul style="list-style-type: none"> • 8-beep tone • Tone issued once every 60 minutes starting after 72 hours of Pod life • After 79 hours of Pod life, tone is issued once every 5 minutes <p>Controller sound and vibration:</p> <ul style="list-style-type: none"> • 3-second tone • 3-second vibration • Vibration and tone repeat every 15 minutes until acknowledged
<p>Lock Screen:</p> 	<p>What to do:</p> <ol style="list-style-type: none"> 1. Tap OK. 2. Change your Pod.
<p>Note: After acknowledgement or if ignored, the alarm will repeat when there is 1 hour left of Pod life.</p> <p>Note: This escalates to the Pod Expired Hazard Alarm if ignored.</p>	

! Pod Shut-Off

Screen Alert	Description
<p>Omnipod 5 App:</p> <div data-bbox="149 313 434 654" style="border: 1px solid black; padding: 10px;"> <p style="text-align: center;">Pod Shutdown</p> <div style="text-align: center;">  </div> <p>The Omnipod 5 app has not communicated with your Pod in the last 4 hours. Tap OK to communicate with your Pod.</p> <div style="text-align: center; margin-top: 10px;"> OK </div> </div>	<p>Why it occurs: You have reached the Pod Shut-Off time you set. The Pod will stop delivering soon if you do not respond to this alarm.</p> <p>Pod sound:</p> <ul style="list-style-type: none"> • 6-beep tone • Once every minute for 15 minutes <p>Controller sound and vibration:</p> <ul style="list-style-type: none"> • 3-second tone • 3-second vibration • Vibration and tone repeat every 15 minutes until acknowledged <p>What to do:</p> <ul style="list-style-type: none"> ➤ Tap NEXT to reset the Pod Shut-Off timer.
<p>Lock Screen:</p> <div data-bbox="130 892 462 968" style="border: 1px solid black; padding: 5px;"> <p>Pod Shutdown The Omnipod 5 app has not comm.. </p> </div>	
<p>Note: To enable or disable the Pod Shut-Off feature or to change the countdown period, see “Pod Shut-Off” on page 128.</p>	

! Start Insulin

Caution: ALWAYS tap START INSULIN to start insulin delivery after a pause period has ended during Manual Mode use. Insulin delivery does not automatically start after a pause. If you do not start insulin delivery, you could develop hyperglycaemia.

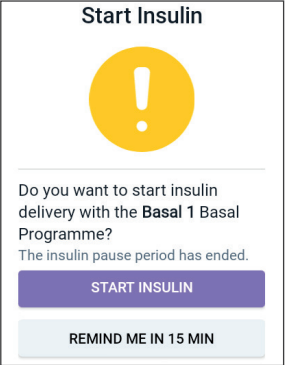
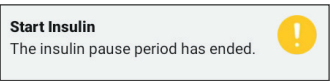
Screen Alert	Description
<p>Omnipod 5 App:</p> 	<p>Why it occurs: The time period that you specified to pause insulin has passed. If you do not start insulin delivery, you could develop hyperglycaemia.</p> <p>Pod sound:</p> <ul style="list-style-type: none"> • 8-beep tone • Tone sounds once every minute for 3 minutes • Repeats every 15 minutes until acknowledged <p>Controller sound and vibration:</p> <ul style="list-style-type: none"> • 3-second tone • 3-second vibration • Vibration and tone repeat every 15 minutes until acknowledged
<p>Lock Screen:</p> 	<p>What to do:</p> <p>Do one of the following:</p> <ul style="list-style-type: none"> • If you want to start insulin with the Basal Programme, tap START INSULIN. • If you want to keep insulin paused, tap REMIND ME IN 15 MIN.

13 Alarms, Action and Reminder Notifications

! Urgent Low Glucose

Warning: ALWAYS promptly treat low glucose. Glucose at or below 3.1 mmol/L (55 mg/dL) indicates significant hypoglycaemia (very low glucose). If left untreated, this could lead to seizure, loss of consciousness or death. Follow your healthcare provider's recommendations for treatment.

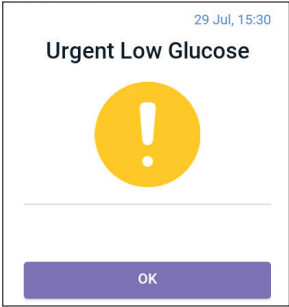
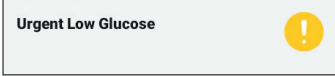
Screen Alert	Description
<p>Omnipod 5 App:</p> 	<p>Why it occurs: Your glucose is at or below 3.1 mmol/L (55 mg/dL), according to what your Sensor sent to the Omnipod 5 App.</p> <p>Pod sound:</p> <ul style="list-style-type: none"> • 4-beep tone • Repeats every 5 minutes that sensor glucose value is urgently low <p>Controller sound and vibration:</p> <ul style="list-style-type: none"> • 3-second tone • 3-second vibration • Vibration and tone repeat every 15 minutes until acknowledged
<p>Lock Screen:</p> 	<p>What to do:</p> <ul style="list-style-type: none"> ➤ Tap OK to acknowledge the alarm.
<p>Note: This Advisory Alarm will only stop repeating after a glucose value of 3.2 mmol/L (56 mg/dL) or greater is received. You may silence this Advisory Alarm for 30 minutes by acknowledging the on-screen message.</p> <p>Note: After the initial Advisory Alarm is acknowledged, the Advisory Alarm will occur again if sensor glucose values are still below 3.1 mmol/L (55 mg/dL) after 30 minutes.</p> <p>Note: Use a blood glucose meter to confirm your blood glucose reading. Treat low glucose as needed.</p> <p>Note: The Urgent Low Glucose Advisory Alarm has to do directly with your body's current glucose, while other alarms have to do with the Pod or Omnipod 5 App state.</p>	

13.8 Action Item Notification List

Action Item notifications are for technical System tasks that need your attention.

App Use Blocked

Warning: You will NOT be able to use the Omnipod 5 App if:

- You have not installed a required update to the Omnipod 5 App
- An update for the Omnipod 5 App is not yet available to fix a known issue

Use a different insulin delivery method. Failure to deactivate your Pod and use another form of insulin delivery could result in over-delivery or under-delivery of insulin. This can lead to hypoglycaemia or hyperglycaemia.

Screen Alert	Description
<p>Omnipod 5 App:</p> <div data-bbox="266 830 555 1307" style="border: 1px solid black; padding: 10px; text-align: center;"> <p>App use blocked</p>  <p>Due to a software issue, the Omnipod 5 app cannot be used. Use a different insulin delivery method until an update is available.</p> <p>Check the app frequently for updates.</p> <p>DEACTIVATE POD</p> </div>	

✎ Connect to a Wireless Network

Caution: Connect ONLY to trusted Wi-Fi networks with your Controller. AVOID connecting to public Wi-Fi networks, such as those found in airports, coffee shops, etc., as these networks are not secure and could result in exposing your Controller to malware. DO NOT connect to public Wi-Fi networks during first-time setup of your Omnipod 5 System.

Screen Alert	Description
<p>Omnipod 5 App:</p> <div data-bbox="173 515 468 926" style="border: 1px solid black; padding: 10px; text-align: center;"> <p>Connect to a wireless network</p>  <p>You need network connectivity to download the latest app. Move to an area with a better signal, or connect to Wi-Fi.</p> <p style="background-color: #4a7ebb; color: white; padding: 5px; display: inline-block;">WI-FI SETTINGS</p> </div>	<p>Why it occurs: Your Omnipod 5 App has not connected to Insulet’s network for 7 or more days.</p> <p>Pod sound: None</p> <p>Controller sound and vibration:</p> <ul style="list-style-type: none"> • 3-second tone • 3-second vibration • No repetition <p>What to do:</p> <p>➤ Tap WI-FI SETTINGS when prompted. Connect to a Wi-Fi network.</p>

Tip: When you are connected to a network, your Omnipod 5 App is notified about software updates when you need them.

Tip: If Wi-Fi is not available, move to an area with a better mobile phone signal.

Note: The SIM Card on your Omnipod 5 Controller enables data to be sent and received via the AT&T wireless network when your Controller is not connected to a Wi-Fi network. If you stop using the Omnipod 5 App over a mobile network on your Controller, Insulet may deactivate the SIM Card.

Note: Please note that the Controller is still functional using Wi-Fi. If you return to using the Omnipod 5 App on your Controller after a significant period of time, please contact Customer Care to request SIM card reactivation for full coverage via both mobile network and Wi-Fi. Upon request, the SIM card is reactivated.

🕒 Daylight Saving Time Change

Caution: ALWAYS be aware of possible changes to your time zone when travelling. If you do not update your time zone, your insulin therapy will be delivered based on your old time zone, which may cause disruptions in your insulin delivery schedule and inaccurate history logs. Talk to your healthcare provider about how to manage your insulin delivery while travelling between time zones.

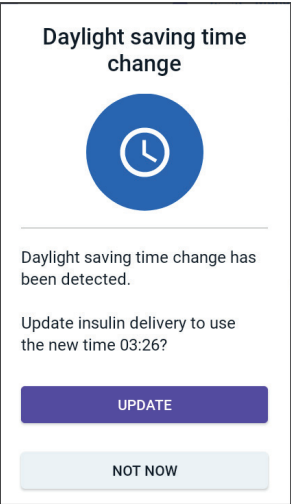
Screen Alert	Description
<p>Omnipod 5 App:</p>  <p>Daylight saving time change has been detected.</p> <p>Update insulin delivery to use the new time 03:26?</p> <p>UPDATE</p> <p>NOT NOW</p>	<p>Why it occurs: The Omnipod 5 App has detected that Daylight Saving Time has started or ended.</p> <p>Pod sound: None</p> <p>Controller sound and vibration:</p> <ul style="list-style-type: none"> • 3-second tone • 3-second vibration • No repetition <p>What to do:</p> <ul style="list-style-type: none"> ➤ Tap UPDATE to update your insulin delivery time. <p>Or:</p> <ul style="list-style-type: none"> ➤ Tap NOT NOW to continue using your current insulin delivery time.
<p>Note: Correct time is essential for correct insulin delivery and history records. If you tap NOT NOW, you can find this Action Item notification at Menu button (☰) > Notifications and every 24 hours you will be reminded to update.</p>	

📱 Omnipod 5 Error

Screen Alert	Description
<p>Omnipod 5 App:</p> <div style="border: 1px solid black; padding: 10px; margin: 10px 0;"> <p style="text-align: center;">Omnipod® 5 error</p> <div style="text-align: center;">  </div> <hr style="width: 20%; margin: 10px auto;"/> <p style="font-size: small;">Restart your device. If problem persists, contact Customer Care using the information given by your provider.</p> <p style="font-size: x-small;">Ref: 0001</p> <div style="text-align: center; margin-top: 10px;"> RESTART </div> </div>	<p>Why it occurs: Your Omnipod 5 App has encountered a problem.</p> <p>Pod sound: None</p> <p>Controller sound and vibration:</p> <ul style="list-style-type: none"> • 3-second tone • 3-second vibration • No repetition <p>What to do:</p> <ul style="list-style-type: none"> ➤ Tap RESTART to restart your device.

Update Omnipod 5 - App No Longer Supported

Caution: ALWAYS make sure your battery has adequate charge prior to installing a software update.

Description

Why it occurs: The Omnipod 5 App version you are currently using is obsolete and no longer supported.

Pod sound: None

Controller sound and vibration:

- 3-second tone
- 3-second vibration
- No repetition

What to do:

1. Tap UPDATE NOW.
Your battery power must be above 15% before updating.
2. If you do not have enough battery power, charge your battery before continuing.
You will see that the update is in progress.
3. When you see the message that the update was successful, tap OK.



Note: If the update is critical (required), you will not have the option to dismiss the notification. If you tap NOT NOW, you can find this Action Item notification at Menu () > Notifications.

Update Omnipod 5 - Software Update

Caution: ALWAYS make sure your battery has adequate charge prior to installing a software update.

Description
Why it occurs: An Omnipod 5 App software update is available.
Pod sound: None
Controller sound and vibration: <ul style="list-style-type: none">• 3-second tone• 3-second vibration• No repetition
What to do: <ol style="list-style-type: none">1. Tap UPDATE NOW. Your battery power must be above 15% before updating.2. If you do not have enough battery power, charge your battery before continuing.3. When you see the message that the update was successful, tap OK.

Update OS

Screen Alert	Description
<p>Omnipod 5 App:</p> <div data-bbox="239 319 532 735" style="border: 1px solid black; padding: 10px; text-align: center;"> <p>Update OS</p>  <p>Update to the latest version of the operating system.</p> <p>(This will not affect your insulin delivery.)</p> <p>UPDATE NOW</p> </div>	<p>Why it occurs: An operating system update is available for your Controller.</p> <p>Pod sound: None</p> <p>Controller sound and vibration:</p> <ul style="list-style-type: none"> • 3-second tone • 3-second vibration • No repetition <p>What to do:</p> <ol style="list-style-type: none"> 1. Tap UPDATE NOW Your battery power must be above 40%, or be above 20% and charging, before updating. 2. If you do not have enough battery power, charge your battery before continuing. 3. When you see the message that the update was successful, tap OK.
<p>Note: If the update is critical (required), you will not have the option to dismiss the notification. If you tap NOT NOW, you can find this Action Item notification at Menu button () > Notifications.</p>	

🕒 Update Time Zone

Caution: ALWAYS be aware of possible changes to your time zone when travelling. If you do not update your time zone, your insulin therapy will be delivered based on your old time zone, which may cause disruptions in your insulin delivery schedule and inaccurate history logs. Talk to your healthcare provider about how to manage your insulin delivery while travelling between time zones.

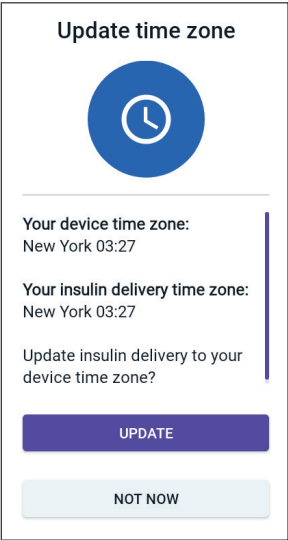
Screen Alert	Description
<p>Omnipod 5 App:</p> 	<p>Why it occurs: Your Controller time zone does not match the Omnipod 5 App insulin delivery time zone.</p> <p>Pod sound: None</p> <p>Controller sound and vibration:</p> <ul style="list-style-type: none"> • 3-second tone • 3-second vibration • No repetition <p>What to do:</p> <ol style="list-style-type: none"> 1. Tap UPDATE when prompted to update your insulin delivery time zone. 2. If you are in Automated Mode, follow the on-screen instructions to switch to Manual Mode and pause insulin delivery. 3. After the time zone is updated, you may start insulin delivery and return to Automated Mode.
<p>Note: Correct time is essential for correct insulin delivery and history records. If you tap NOT NOW, you can find this Action Item notification at Menu button (☰) > Notifications and every 24 hours you will be reminded to update.</p>	

13.9 Silencing Unresolved Alarms

You can silence Pod or Omnipod 5 App alarms by acknowledging the alarm screen displayed on your Omnipod 5 App. If the alarm continues, follow the directions in this section.

Pod Alarm

Caution: Permanently silencing a Pod alarm requires the Pod to be removed from your body. Once removed and discarded, promptly activate a new Pod to avoid going too long without insulin, which could lead to hyperglycaemia.

To permanently silence a Pod alarm:

1. If the Pod is on your body, remove it.
2. Peel back a little bit of the adhesive pad from the bottom of the Pod at the square end (see figure).
3. Locate the alarm shut-off port to the right of the gold circle. The alarm shut-off port can be felt with a fingernail or paper clip as soft plastic.
4. Firmly press a paper clip or similar item straight down into the alarm shut-off port. You need to apply enough force to break a thin layer of plastic. If an alarm is sounding, the alarm will stop.

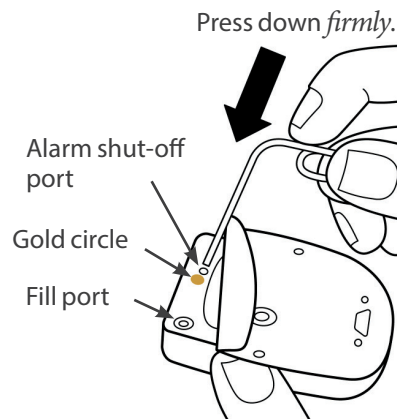

Controller Alarm

If a Controller alarm is not silenced when you acknowledge the alarm:

1. Press and hold the Power button, then tap Power off.
2. Press and hold the Power button to turn the Controller back on.

This action silences the Controller's alarm. Your history records and personal settings are preserved. However, you may have to confirm the time zone.

13.10 Responding to Reminder Notifications

Reminder Notifications remind you about diabetes management actions you may want to perform.

Finding out about Reminder notifications

To alert you to a notification, the Pod sounds a 3-beep tone, and the Omnipod 5 App either sounds a tone or vibrates (see “13.3 Sounds and Vibrations” on page 153). When you hear a sound or feel a vibration, check your Omnipod 5 App for a message.

Note: Programme Reminders, confidence Reminders and some informational signals do not have an accompanying message.

If your Omnipod 5 App is asleep when you hear or feel a notification, wake it up. The Lock screen shows the Reminder notification icon () and the notification message.

- If there are multiple messages, the most recent message is shown at the top of the list.
- If there are more messages than can be displayed on the Lock screen, a banner beneath the messages shows the number of additional messages.

If you are using your Omnipod 5 App when a notification is triggered, the notification message appears at the top of the screen. To remove the message from the screen:

- Do nothing. The message disappears after several seconds and is saved as a new message.
- Swipe up to remove the message immediately and save it as a new message.
- Swipe right to remove the message immediately and save it as an acknowledged message.

Acknowledging Reminder notifications

Note: Waking up your Omnipod 5 App and using it does not automatically acknowledge or silence notifications.

All new notifications are included in the Notifications & Alarms count () in the red circle over the notification bell in the upper right of the Home screen.

To acknowledge the notification:

1. Wake up your Omnipod 5 App.
2. Tap the notification bell icon () to bring up the Notifications & Alarms screen.

3. Scroll down the screen, if necessary, to see any additional notifications with blue icons (🕒).
4. Tap the back arrow (←) in the upper left of the screen to mark the notifications as acknowledged.

Note: Putting the Omnipod 5 Controller to sleep by pressing the Power button does not mark the notifications as acknowledged. You must tap the back arrow (←) to acknowledge the notification.

13.11 Reminder Notifications List

Reminder Notifications remind you about various diabetes management actions you may want to perform. Some are automatically generated and others have settings that you control (see “10.2 Reminder Settings” on page 127).

Tip: Use the Sound/vibrate button on the right side of the Controller to control whether the notification sounds a tone or vibrates (see “The Sound/vibrate button on your Controller” on page 153).

The Reminder notifications are:

🕒 No Active Pod

Screen Displayed	<div style="border: 1px solid #ccc; padding: 5px; background-color: #f9f9f9;"> <p>No Active Pod </p> <p>Activate a Pod to start insulin deliv..</p> </div>
Cause	Reminds you to activate a new Pod to begin basal insulin delivery
Pod sound:	None
Controller sound and vibration:	Repeats once, 15 minutes after initial notification, unless acknowledged.
What to do	Unlock the Omnipod 5 App. Activate a new Pod.

13 Alarms, Action and Reminder Notifications

Pod Expiry

Screen Displayed	Pod Expiry Pod expires at 06:40, 01/07/2023 
Cause	Tells you how much time is left before the Pod expiry Advisory Alarm.
Pod sound:	<ul style="list-style-type: none">• 8-beep tone• Tone issued once every minute for 3 minutes• Repeats every 15 minutes until acknowledged
Controller sound and vibration:	Repeats once, 15 minutes after initial notification, unless acknowledged.
What to do	Acknowledge the message (see “Acknowledging Reminder notifications” on page 180). Change your Pod.

Note: To change the timing of this notification, see “Pod Shut-Off” on page 128. Both the Pod and the Omnipod 5 App sound the notification.

CHAPTER 14

Taking Care of Your Controller and Pod

Contents

14.1 Pod and Insulin Storage and Care	184
Pod and Insulin Storage	184
Pods and the Environment	184
Avoid extreme temperatures	184
Water and your Pod	185
Cleaning Your Pod	185
14.2 Controller Storage and Care	185
Long-term storage of your Controller	186
Your Controller and the Environment	186
Avoid extreme temperatures	186
Water and your Controller	186
Electrical interference	186
USB charging cable and adapter	187
Cleaning Your Controller	187
If You Drop the Controller	188
14.3 Controller Battery Care	188
Safe Use of the Controller Battery	188
Charging the Controller Battery	189

14 Taking Care of Your Controller and Pod

Warning: DO NOT expose any Omnipod 5 System products or supplies to extreme temperatures as this results in them not functioning properly. Store all Omnipod 5 System products and supplies, including unopened Pods, in a cool, dry place.

The Omnipod 5 Automated Insulin Delivery System has no user-serviceable parts. If you require assistance operating or maintaining the Omnipod 5 System, contact Customer Care.

14.1 Pod and Insulin Storage and Care

This section describes proper care of your Pod.

Pod and Insulin Storage

Extreme heat or cold can damage Pods and cause them to malfunction.

It is especially important to store your insulin in a well-controlled environment. Inspect insulin before using it; never use insulin that looks cloudy or discoloured. Insulin that is cloudy or discoloured may be old, contaminated or inactive. Check the insulin manufacturer's instructions for use and the insulin's expiry date.

Pods and the Environment

Avoid extreme temperatures

Warning: DO NOT expose a Pod to direct sunlight for long periods of time. Remove your Pod prior to using hot tubs, whirlpools or saunas. These conditions could expose the Pod to extreme temperatures and may also affect the insulin inside the Pod, which could lead to hyperglycaemia.

The Pod's operating temperature has been tested and found to operate safely between 5°C and 40°C (between 41°F and 104°F). Under normal circumstances, your body temperature keeps the Pod within a range of 23°C and 37°C (73°F and 98.6°F).

Caution: NEVER use a hairdryer or hot air to dry the Controller or Pod. Extreme heat can damage the electronics.

If you remove your Pod to avoid exposing it to extreme temperatures, remember to check your glucose frequently.

Note: Check with your healthcare provider for guidelines if you plan on not using a Pod for extended periods.

Note: Check the labelling for your rapid-acting insulin, as maximum insulin exposure temperatures may vary between insulins.

Water and your Pod

Warning: DO NOT expose your Pod to water at depths greater than 7.6 m (25 ft) or for longer than 60 minutes because damage to the Pod can occur. This could result in over-delivery or under-delivery of insulin, which can lead to hypoglycaemia or hyperglycaemia.

The Pod is waterproof up to a depth of 7.6 m (25 ft) for up to 60 minutes (IP28). After swimming or similar exposure to water, rinse off the Pod with clean water and gently dry it with a towel.

Cleaning Your Pod

Pods are waterproof. If you need to clean a Pod, gently wash it with a clean, damp cloth, or you can use mild soap and water. However, do not use strong detergents or solvents, as they can damage the Pod's casing or irritate the infusion site.

Caution: Use caution while cleaning the Pod on your body. Hold the Pod securely so the cannula does not kink and the Pod does not detach from your skin.

14.2 Controller Storage and Care

When you are not using your Controller, store it in a convenient, nearby location that is cool and dry.

Caution: ALWAYS keep your Controller safe and within your control to ensure others cannot make changes to your insulin therapy. Do not share your Controller screen lock security with anyone.

Caution: DO NOT use any component of the Omnipod 5 System (Controller, Pod) if you suspect damage after an unexpected event such as dropping or hitting on a hard surface. Using damaged components may put your health at risk as the system may not be working properly. If you are unsure if one or more of your components are damaged, stop using the system and contact Customer Care for support.

14 Taking Care of Your Controller and Pod

Long-term storage of your Controller

If you are not going to use your Controller for an extended period of time, allow your battery to reach approximately 50% to 60% charge. Then press and hold the Power button to turn the Controller OFF.

Your Controller and the Environment

Avoid extreme temperatures

Extreme operating temperatures can affect the Controller battery and interfere with Omnipod 5 System operation. Avoid using the Controller in temperatures below 5°C (41°F) or above 40°C (104°F).

Caution: DO NOT expose your Controller to extreme temperatures while in storage or during use. Extreme heat or cold can cause the Controller to malfunction. Extreme heat is defined as >30°C (86°F) during storage and >40°C (104°F) during use. Extreme cold is defined as < 0°C (32°F) during storage and < 5°C (41°F) during use.

Water and your Controller

Caution: DO NOT place the Controller in or near water because the Controller is not waterproof. Failure to do so may result in damage to the Controller.

If the Controller gets wet:

1. Dry the outside of the Controller with a clean, lint-free cloth.

Caution: NEVER use a hairdryer or hot air to dry the Controller or Pod. Extreme heat can damage the electronics.

2. After the Controller has thoroughly air-dried, turn ON the Controller to see if it is working.
3. If the Controller is not working, contact Customer Care.

Electrical interference

The Controller and Pod are designed to withstand normal radio interference and electromagnetic fields, including airport security and mobile phones. However, as with all wireless communication technology, certain operating conditions can interrupt communication. For example, electric appliances such as microwave ovens and electric machinery located in manufacturing environments may cause interference. In most cases, interruptions are easy to resolve by moving to a new location (for more information, see “26.5 Pod Communication Issues – “Try Again”” on page 374).

USB charging cable and adapter

Caution: Use ONLY the USB charging cable and adapter that you received in the box with your Controller. AVOID using alternative charging cables or other accessories, as they may damage the Controller or affect the way it charges in the future. If you must use a different cable, use only cables less than or equal to 1.2 m (4 ft) in length.

Note: You can use the Controller while it is charging.

Cleaning Your Controller

Always keep your Controller USB port free of debris and liquids. Dirt, dust, and liquids can impair the functionality of your Controller or damage it. Use compressed air to clean any dust. Never blow in the port with your mouth.

Caution: DO NOT use solvents to clean your Controller. DO NOT immerse your Controller in water as it is not waterproof. The use of solvents or immersion in water could cause the Controller to malfunction.

To clean your Controller:

1. Press the Power button briefly to put your Controller to sleep.
2. Wipe the outer surface of the Controller with a damp, lint-free cloth. If necessary, use a solution of a mild detergent mixed in warm water on the cloth.
3. Dry the outer surface with a dry, lint-free cloth.

Caution: DO NOT allow debris or liquid to get into the USB port, speaker, sound/vibrate button or Power button while cleaning the Controller. Failure to do so may result in damage to the Controller.

Every time you clean your Controller, examine the entire Controller for discoloration, cracks or separations. Also check for deteriorating performance, such as illegible messages, button malfunction, or repeated communication failures. If you notice any signs of deterioration, stop using the Controller. Contact Customer Care if you have questions.

14 Taking Care of Your Controller and Pod

If You Drop the Controller

Shock or a severe impact can damage your Controller. If you drop the Controller or if it is otherwise subjected to severe impact:

1. Inspect the outside of the Controller for visible signs of damage.
2. If the Controller has turned off, press and hold the Power button to see whether the Controller turns on and the Lock screen appears.

Caution: Do not use the Controller if it appears damaged or is not working as it should. Do not use the Controller if its screen is broken.

14.3 Controller Battery Care

The Controller provided uses a rechargeable lithium polymer battery. The battery cannot be removed from your Controller. If there is a problem with your battery or charging cable and adapter, contact Customer Care.

Safe Use of the Controller Battery

Caution: DO NOT expose your Controller battery to high heat $>30^{\circ}\text{C}$ ($>86^{\circ}\text{F}$) during storage and $>40^{\circ}\text{C}$ ($>104^{\circ}\text{F}$) during use. Do not puncture, crush or apply pressure to your battery. Failure to follow these instructions could result in an explosion, fire, electric shock, damage to the Controller or battery, or battery leakage.

To safely use the rechargeable battery:

- Store and charge the Controller in a cool, dry place out of direct sunlight to prolong battery life. Avoid leaving the Controller in a car where temperature extremes can permanently damage the battery.
- Your Controller may become warm after prolonged use or when exposed to high temperatures. If your Controller becomes hot to the touch, unplug the USB charging cable and adapter if it is plugged in, and avoid touching or holding the Controller. Place it in a cool location and allow it to cool down to room temperature.
- Do not expose the charging cable and adapter to liquids, including water, rain, or snow, as this can cause malfunction. If the battery or charging cable and adapter is exposed to liquid, allow it to dry.

- Do not place the Controller on or in heating devices, such as microwave ovens, stoves or radiators. The battery may explode if overheated.
- Do not drop the Controller.
- Only use an Insulet-approved charging cable and adapter to charge your Controller. Using unapproved charging cables and adapters can cause the battery to explode or damage the Controller, and may void the warranty.
- If the battery is damaged so that fluid leaks from the battery, do not allow the leaked fluid to make direct contact with your skin or eyes. If this happens, immediately flush your skin or eyes with clean water and consult a doctor.
- Inspect your Controller battery charging cable and adapter before each use. If the adapter for the charging cable falls in water or is cracked, do not use it.

Charging the Controller Battery

Caution: ALWAYS plug in and charge your Controller when you see the low battery message. If the battery charge becomes critically low, the Controller turns itself off, and you will not receive a low battery Hazard Alarm. Without the use of the Controller, you will not be able to make changes to your insulin delivery, which could result in over-delivery or under-delivery of insulin, which can lead to hypoglycaemia or hyperglycaemia.

Under normal use, the battery should hold its charge for more than one day.

An Omnipod 5 App message alerts you when the battery charge is low. The battery icon in the status bar tracks the remaining charge in the battery (see “3.4 Status Bar” on page 44).

Note: Check the charging port and the charging cable for any signs of dust or debris. Use compressed air to clean any dust. Never blow in the port with your mouth.

14 Taking Care of Your Controller and Pod

To charge your Controller:

1. Assemble the charging cable by attaching its wall adapter.

Caution: Use ONLY the USB charging cable and adapter that you received in the box with your Controller. AVOID using alternative charging cables or other accessories, as they may damage the Controller or affect the way it charges in the future. If you must use a different cable, use only cables less than or equal to 1.2 m (4 ft) in length.

2. Plug the charging cable and adapter into an outlet. Select an outlet that you can access easily and unplug the charging cable and adapter from easily when necessary.
3. Plug the other end of the cable into the USB port of the Controller.
4. Charge the Controller until the battery level icon shows 100% charge.
5. Disconnect the charging cable and adapter from the Controller and the wall outlet.

You can charge your battery many times, but all batteries have a limited lifespan. Contact Customer Care if you notice a significant deterioration in the duration of the Controller's battery charge.

Note: Charging times can vary depending on the surrounding temperature and the remaining battery level.

Tip: Develop a routine to charge the Controller battery at the same time every day. Do not wait for the low battery message.

Note: If the Controller battery is critically low and the Controller has turned OFF, your Pod continues to deliver Automated Mode insulin or Manual Mode basal insulin according to the Basal Programme in progress or Temp Basal. If you do not charge your Controller battery, this insulin delivery continues until the Pod expires.

Note: The history records stay in memory for 1 year even if the battery power is critically low.

CHAPTER 15

Living with Diabetes

Contents

15.1 Infusion Site Checks	192
15.2 Being Aware of Your Glucose	193
15.3 Travelling and Holidays	194
Keep Supplies Accessible	194
Plan for Changing Time Zones.....	195
Airports and Flying.....	195
Airport security.....	195
Flying and flight mode.....	196
15.4 Avoiding Lows, Highs, and Diabetic Ketoacidosis	196
General Precautions	197
Hypoglycaemia (Low Glucose)	197
Symptoms of hypoglycaemia (low glucose).....	197
To avoid hypoglycaemia (low glucose)	198
To treat hypoglycaemia (low glucose).....	199
Hyperglycaemia (High Glucose).....	200
Symptoms of hyperglycaemia (high glucose).....	200
To avoid hyperglycaemia (high glucose)	200
To Treat Hyperglycaemia (High Glucose).....	202
Diabetic Ketoacidosis (DKA)	203
Symptoms of DKA.....	203
To avoid DKA.....	203
To treat DKA	204
15.5 Handling Special Situations	204
Sick Days	204
Exercising, Playing Sports or Working Hard	205
X-rays, MRIs and CT Scans.....	205
Surgery or Hospitalisation	206

15.1 Infusion Site Checks

Caution: ALWAYS check for signs of infection often. If an infusion site shows signs of infection:

- Immediately remove the Pod and apply a new Pod at a different infusion site.
- Contact your healthcare provider. Treat the infection according to instructions from your healthcare provider.

If you see blood in your cannula, check your glucose more frequently to ensure insulin delivery has not been affected. If you experience unexpected high glucose, change your Pod.

At least once a day, use the Pod's viewing window to inspect the infusion site. Check the site for:

- Leakage or scent of insulin, which may indicate the cannula has dislodged.
- Signs of infection, such as pain, swelling, redness, discharge or heat.

Tip: Consider making infusion site checks a part of your daily routine, like showering or brushing your teeth.

15.2 Being Aware of Your Glucose

Warning: ALWAYS be aware of your current sensor glucose value, trust how your body feels and do not ignore symptoms of high and low glucose. Even though insulin delivery adjusts automatically in Automated Mode, with the goal of bringing your glucose level to your defined Target Glucose, severe hypoglycaemia or hyperglycaemia may still occur.

If your sensor glucose values do not match your symptoms, ALWAYS check your blood glucose using a BG meter and consider treatment and/or Sensor calibration if necessary. ALWAYS switch to Manual Mode if you feel you are receiving inaccurate sensor glucose values.

- Erroneously high sensor glucose values can cause excessive insulin delivery, leading to severe hypoglycaemia, seizure, loss of consciousness or death.
- Erroneously low sensor glucose values can cause prolonged insulin suspension, leading to hyperglycaemia, DKA or death.

If you are having symptoms that are not consistent with your blood glucose readings and you have followed all instructions described in this *Technical User Guide*, contact your healthcare provider.

When you routinely view your sensor glucose values and/or check your glucose, you can better identify when you need to make a treatment decision or troubleshoot an issue. If you are not wearing a Sensor, it is advisable to check your blood glucose at least 4–6 times per day (when you wake up, before each meal, and before going to bed).

Check your glucose:

- Whenever you feel nauseous or sick.
- Before driving a car.
- Whenever your glucose has been running unusually high or low.
- If you suspect that your glucose is high or low.
- Before, during and after exercise.
- As directed by your healthcare provider.

When using a Sensor, if your sensor glucose values are different than what you expect based on how you feel, then check your blood glucose using a BG meter to verify your sensor glucose value's accuracy. For example, if you feel shaky and sweaty, which usually means your glucose is very low, but your sensor glucose value shows as in your acceptable range, you should confirm by checking with your BG meter.

15 Living with Diabetes

If your blood glucose readings are verified too low or too high, consider treatment.

A Sensor calibration may also be needed if you use the Dexcom G6 Sensor; consult your *Dexcom G6 System Instructions for Use* for more information.

15.3 Travelling and Holidays

It is important that you check your glucose more frequently while you are travelling. Changes in time zones, activity levels and mealtimes can all affect your glucose.

Proper preparation is important when travelling. The following sections will help you prepare for your travels.

Keep Supplies Accessible

On aeroplanes, trains and buses, keep these items with you, rather than checking them in:

- Your Controller
- Extra Pods
- An emergency kit
- Vials of insulin (cargo area temperatures may affect insulin)
- A signed letter from your healthcare provider explaining that you need to carry insulin supplies and the Omnipod 5 System
- Prescriptions for all medications
- Medications and supplies with their original prescription label

Note: Generic medications may be easier to find than brand names outside your country.

- Snacks and hypoglycaemia treatment, in case food is not available
- Bottled water (especially on planes) to prevent dehydration
- The name and phone number of your doctor and of a doctor at your final destination

Note: For information about the recommended glucose sensing supplies to carry, see the *Instructions for Use* for your compatible glucose Sensor.

Note: Keep your emergency kit with you during trips or holidays (see “Emergency Kit” on page 15). As it may be difficult or impossible to get insulin or supplies in an unfamiliar place, take more supplies than you think you’ll need.

Tip: When you travel outside the country or for long periods of time, be sure to take extra Pod supplies. Prior to departure, contact Customer Care to inquire about additional Omnipod 5 System supplies for your trip.

Plan for Changing Time Zones

If you're planning a holiday or business trip to a different time zone, you may need to adjust Basal Programmes that you would typically follow while in Manual Mode. For changes of just a few hours, basal rate adjustments are minor and easy to calculate. For long-distance travel, however, figuring out the correct Basal Programme can be more challenging. Your healthcare provider can help with these adjustments.

Airports and Flying

Before travelling by plane, familiarise yourself with the airport's security procedures and prepare your diabetes supplies for the security process and flight.

Airport security

Prepare for your travel:

- Airport security checks and screening procedures may change, so review the airport website and the transport security website for travel updates before your trip.
- Arrive at the airport 2–3 hours before your flight.
- Have your insulin management supplies easily accessible to ensure that airport security checks run smoothly.

The airport may offer the option of requesting a visual inspection of your medical supplies rather than putting them through the X-ray. You must request this before the screening process begins. Your medical supplies should be in a separate bag when you approach the security officer.

To prevent contamination or damage to your supplies, you should be asked at the security checkpoint to display, handle and repack your own supplies during the visual inspection process. Any medication and/or associated supplies that cannot be cleared visually must be submitted for X-ray screening.

If you are concerned about going through the walk-through metal detector, notify the security officer that you're wearing an insulin pump. You should advise the security officer that the insulin pump cannot be removed because it is inserted with a catheter (tubing) under the skin.

Visit the transport security Contact Centre if you have any further questions or concerns.

15 Living with Diabetes

Note: For information about passing glucose sensing equipment through airport X-ray machines, see the *Instructions for Use* for your compatible glucose Sensor.

Flying and flight mode

Caution: ALWAYS check your glucose frequently during amusement park rides and flying, or other situations where sudden changes or extremes of air pressure, altitude or gravity may be occurring. Though the Omnipod 5 System is safe to use at atmospheric pressures typically found in aeroplane cabins during flight, the atmospheric pressure in an aeroplane cabin can change during flight, which may affect the Pod's insulin delivery. Rapid changes in altitude and gravity, such as those typically found on amusement park rides or flight take-off and landing, can affect insulin delivery, leading to possible hypoglycaemia or injury. If needed, follow your healthcare provider's treatment instructions.

The Omnipod 5 System sends and receives information from the Pod using Bluetooth wireless technology. Before flying, check your airline's policy regarding the use of Personal Medical Electronic Devices that communicate using Bluetooth technology.

If the use of a Personal Medical Electronic Device using Bluetooth technology is allowed, set your Omnipod 5 App to flight mode while on the aeroplane (see "Flight mode" on page 123). The Bluetooth setting remains enabled in the Controller's Flight Mode so you can communicate with your Pod.

Note: The Omnipod 5 System is safe to use at atmospheric pressures typically found in aeroplane cabins during flight. The Omnipod 5 System can be used at atmospheric pressures as low as 700 hPa, which is lower than the typical pressure in aeroplane cabins.

15.4 Avoiding Lows, Highs, and Diabetic Ketoacidosis

You can avoid most risks related to using the Omnipod 5 System by following the instructions in this *Technical User Guide* and by promptly treating symptoms of hypoglycaemia (low glucose), hyperglycaemia (high glucose), or diabetic ketoacidosis (DKA) according to your healthcare provider's instructions. The easiest and most reliable way to avoid these conditions is to check your glucose often.

General Precautions

- Keep careful records and discuss changes and adjustments with your healthcare provider.
- Tell your healthcare provider if you have extreme high glucose or low glucose, or if high glucose or low glucose are occurring more often than usual.
- If you have technical problems with your Omnipod 5 System and cannot resolve them, contact Customer Care immediately.

Hypoglycaemia (Low Glucose)

Warning: DO NOT wait to treat hypoglycaemia (low glucose) or symptoms of hypoglycaemia. Even if you cannot check your glucose, waiting to treat symptoms could lead to severe hypoglycaemia, which can lead to seizure, loss of consciousness, or death.

Hypoglycaemia can occur even when a Pod is working properly. Never ignore the signs of low glucose, no matter how mild. If left untreated, severe hypoglycaemia can cause seizures or lead to unconsciousness. If you suspect that your glucose is low, check your glucose to confirm.

Symptoms of hypoglycaemia (low glucose)

Never ignore the following symptoms, as they could be signs of hypoglycaemia:

- Shakiness
- Sudden hunger
- Fatigue
- Rapid heart rate
- Unexplained sweating
- Confusion
- Cold, clammy skin
- Tingling in the lips or tongue
- Weakness
- Anxiety
- Blurred vision or a headache

Tip: Make sure your glucose is at least 5.6 mmol/L (100 mg/dL) before driving or working with dangerous machinery or equipment. Hypoglycaemia may cause you to lose control of a car or dangerous equipment. Also, when you focus intently on a task, you may miss the symptoms of hypoglycaemia.

Tip: Teach people you trust (like family members and close friends) how to administer a glucagon dosage. You will need to rely on them to give it to you if you have severe hypoglycaemia and become unconscious. Include a copy of the glucagon instructions in your emergency kit and periodically review the procedure with family and friends.

To avoid hypoglycaemia (low glucose)

- Work with your healthcare provider to establish individualised Target Glucose settings and guidelines.
- Keep a fast-acting carbohydrate with you at all times to respond quickly to low glucose. Examples of fast-acting carbs are glucose tablets, hard sweets or juice.
- Teach your friends, family members and colleagues to recognise the signs of hypoglycaemia, so they can help if you develop hypoglycaemia unawareness or a severe adverse reaction.
- Keep a glucagon kit with your emergency supplies. Teach friends and family members how to administer a glucagon dosage in case you have severe hypoglycaemia and become unconscious.

Periodically check the expiry date of your glucagon kit to make sure it has not expired.

Note: Always carry medical identification (such as an emergency wallet card) and wear an emergency medical necklace or bracelet such as the Medic Alert tag.

Again, frequent glucose checks are the key to avoiding potential problems.

Detecting low glucose early lets you treat it before it becomes a problem.

Check with your healthcare provider for guidance in avoiding low glucose.

Possible causes of hypoglycaemia	Suggested action
Incorrect Basal Programme (Manual Mode)	Confirm that the correct Basal Programme is active. Consult your healthcare provider about adjusting your Basal Programmes or using a Temp Basal.
Incorrect bolus timing or bolus too large	Take bolus with food. Check blood glucose before giving a meal bolus. If necessary, adjust the bolus. Check the bolus size and timing. Do not overcorrect for post-meal glucose. Check carb intake. Consult your healthcare provider for guidance.
Incorrect Target Glucose level or incorrect Correction Factor or incorrect IC Ratio	Consult your healthcare provider about refining these settings as needed.

Possible causes of hypoglycaemia	Suggested action
Prone to severe hypoglycaemia or hypoglycaemia unawareness	Consult your healthcare provider about hypoglycaemia unawareness and about raising Target Glucose.
Unplanned physical activity	Consult with your healthcare provider about using Temp Basal (Manual Mode) or the Activity feature (Automated Mode). Adjust insulin delivery as instructed by your healthcare provider. Check glucose before, during, and after activity and treat as necessary.
Prolonged or intense exercise	Note: Effects of exercise can last several hours – even a full day – after activity ends. Consult your healthcare provider about adjusting your Basal Programmes or using a Temp Basal (Manual Mode) or the Activity feature (Automated Mode) to avoid hypoglycaemia.
Low carbohydrate intake prior to activity	Check glucose before activity. Consult your healthcare provider for guidance.
Alcohol consumption	Check glucose frequently, especially before going to bed. Consult your healthcare provider for guidance.

To treat hypoglycaemia (low glucose)

Any time your glucose is low, treat it immediately according to your healthcare provider’s instructions. Your healthcare provider might recommend that you treat hypoglycaemia with a different amount of carbs during Automated Mode compared with Manual Mode. Check your glucose every 15 minutes while you are treating to make sure you don’t overtreat the condition and cause glucose levels to rise too high. Contact your healthcare provider as needed for guidance.

Hyperglycaemia (High Glucose)

Warning: ALWAYS monitor your glucose and follow your healthcare provider's treatment guidelines when you stop receiving insulin due to a blockage (occlusion). Not taking action promptly could result in under-delivery of insulin, which can lead to hyperglycaemia or diabetic ketoacidosis (DKA) (see “ Blockage Detected” on page 158).

Pods use rapid-acting insulin, which has a shorter duration than long-acting insulin, so you have no long-acting insulin in your body when using the Omnipod 5 System. If a blockage (interruption of insulin delivery from the Pod) or occlusion occurs, your glucose can rise rapidly.

Tip: Hyperglycaemia symptoms can be confusing. Always check your glucose before you treat for hyperglycaemia.

Symptoms of hyperglycaemia (high glucose)

Never ignore the following symptoms, as they could be a sign of hyperglycaemia:

- Fatigue
- Frequent urination, especially during the night
- Unusual thirst or hunger
- Unexplained weight loss
- Blurred vision
- Slow healing of cuts or sores

To avoid hyperglycaemia (high glucose)

Check your glucose:

- At least 4–6 times a day (when you wake up, before each meal, and before going to bed), unless you are using a continuous glucose monitoring system.
- If you feel nauseous or sick.
- Before driving a car.
- Whenever your glucose has been running unusually high or low.
- If you suspect that your glucose is high or low.
- Before, during and after exercise.
- As directed by your healthcare provider.

Possible causes of hyperglycaemia	Suggested action
Expired insulin or insulin exposed to extreme temperatures	Deactivate and remove the used Pod. Apply a new Pod filled from a new vial of insulin.
Infusion site in or near a scar or mole	Deactivate and remove the used Pod. Apply a new Pod in a different location.
Infected infusion site	Deactivate and remove the used Pod. Apply a new Pod in a different location and consult your healthcare provider.
Dislodged cannula	Deactivate and remove the used Pod. Apply a new Pod in a different location. Note: Avoid sites near a waistband, belt, or other areas where friction may dislodge the cannula.
Empty Pod	Deactivate and remove the used Pod. Apply a new Pod in a different location.
Incorrect Basal Programme (Manual Mode)	Confirm that the correct Basal Programme is active. Consult your healthcare provider about adjusting your Basal Programmes or using a Temp Basal.
Incorrect bolus timing or bolus too small	Check carb intake. Take bolus with or before eating food rather than after. Check glucose before giving a meal bolus. If necessary, adjust bolus. Consult your healthcare provider for guidance.
High-protein or high-fat meal	Calculate protein/fat intake and account for it in your bolus timing and bolus type. Consult your healthcare provider about using the Extended Bolus option.
Less activity than usual	Consult your healthcare provider about adjusting your Basal Programmes or using a Temp Basal (Manual Mode).

Possible causes of hyperglycaemia	Suggested action
Glucose greater than 13.9 mmol/L (250 mg/dL)(with ketones present) before exercise	Do not exercise when ketones are present. Note: Glucose increases with exercise when ketones are present. Consult your healthcare provider for guidance.
Infection or illness or medication change	See “Sick Days” on page 204. Consult your healthcare provider about sick day guidelines and about medication changes.
Weight loss or gain or menstrual cycle or pregnancy	Consult your healthcare provider for guidance.
Blockage (occlusion)	Deactivate and remove the used Pod. Apply a new Pod in a different location.

To Treat Hyperglycaemia (High Glucose)

Warning: NEVER drive yourself to the emergency department if you need emergency medical care. Ask a friend or family member to take you to the emergency department or call an ambulance.

Always check your glucose frequently while treating hyperglycaemia. You don't want to over-treat the condition and cause your glucose to drop too low.

1. Check your glucose. The result will help you to find out how much insulin is needed to return your glucose to your glucose goal.
2. If your glucose is 13.9 mmol/L (250 mg/dL) or above, check for ketones. If ketones are present, follow your healthcare provider's guidelines.
3. If ketones are not present, take a correction bolus as prescribed by your healthcare provider.
4. Check your glucose again after 2 hours.
5. If glucose has not decreased, do both of the following:
 - Take a second bolus by injection, using a sterile syringe. Ask your healthcare provider whether to inject the same amount of insulin as in step 3.

- Replace the Pod. Use a new vial of insulin to fill the new Pod. Then contact your healthcare provider for guidance.

Note: The Omnipod 5 System cannot track insulin that is administered outside of the system. Consult your healthcare provider about how long to wait after manually administering insulin before you start Automated Mode.

6. If you feel nauseous at any point, check for ketones and contact your healthcare provider immediately.

Diabetic Ketoacidosis (DKA)

Warning: DO NOT wait to treat DKA. If left untreated, DKA can quickly lead to breathing difficulties, shock, coma or death.

Pods use rapid-acting insulin, which has a shorter duration than long-acting insulin, so you have no long-acting insulin in your body when using the Omnipod 5 System. If insulin delivery from the Pod is interrupted (a blockage or occlusion), your glucose can rise rapidly and lead to diabetic ketoacidosis (DKA). DKA is a serious—but preventable—emergency that can occur if high glucose is not resolved, in times of illness, or when there is not enough insulin working in your body.

Symptoms of DKA

- Nausea and vomiting
- Abdominal pain
- Dehydration
- Fruity-smelling breath
- Dry skin or tongue
- Drowsiness
- Rapid pulse
- Laboured breathing

The symptoms of DKA are much like those of the flu. Before assuming you have the flu, check your glucose and check for ketones to rule out DKA.

To avoid DKA

The easiest and most reliable way to avoid DKA is by checking your glucose at least 4–6 times a day. Routine checks allow you to identify and treat high glucose before DKA develops.

To treat DKA

- Once you have begun treatment for high glucose, check for ketones. Check for ketones any time your glucose is 13.9 mmol/L (250 mg/dL) or above.
- If ketones are negative or trace, continue treating for high glucose.
- If ketones are positive and you are feeling nauseous or ill, immediately contact your healthcare provider for guidance.
- If ketones are positive but you are not feeling nauseous or ill, replace the Pod, using a new vial of insulin.
- Check your glucose again after 2 hours. If your glucose has not declined or if your ketone levels have risen or remain elevated, immediately contact your healthcare provider for guidance.

15.5 Handling Special Situations

Sick Days

Any physical or emotional stress can cause your glucose to rise, and illness is physical stress. Your healthcare provider can help you make a plan for sick days. The following are only general guidelines.

When you are ill, check your glucose more often to avoid DKA. The symptoms of DKA are much like those of the flu. Before assuming you have the flu, check your glucose to rule out DKA (see “To Treat Hyperglycaemia (High Glucose)” on page 202).

To handle sick days:

- Treat the underlying illness to promote faster recovery.
- Eat as normally as you can. Your body still needs carbohydrates and insulin for energy.
- Adjust bolus doses, if necessary, to match changes in meals and snacks.
- Always continue your basal insulin, even if you are unable to eat. Contact your healthcare provider for suggested basal rate adjustments during sick days.
- Check your glucose every 2 hours and keep careful records of results.
- Check for ketones when your glucose is 13.9 mmol/L (250 mg/dL) or higher, and/or when you are feeling ill, as ketones can also be present when glucose is in range during illness.

- Follow your healthcare provider's guidelines for taking additional insulin on sick days.
- Drink plenty of fluids to avoid dehydration.
- Contact your healthcare provider if symptoms persist.

Exercising, Playing Sports or Working Hard

Check your glucose before, during and after exercising, playing sports or doing unusually hard physical labour.

The Pod's adhesive keeps it securely in place for up to 3 days. However, if necessary, several products are available to enhance adhesion. Ask your healthcare provider about these products.

Avoid getting body lotion, creams or oils near the infusion site; these products may loosen the adhesive.

For some contact sports, if the Pod is in a location where it is likely to be knocked off, consider removing the Pod and placing a new one in a more protected location.

Make sure to check your glucose before removing the Pod and after applying a new one. Pods are designed for one-time use. Do not attempt to reapply a Pod that has been removed.

If you will need to remove the Pod for more than one hour, ask your healthcare provider to recommend appropriate guidelines.

X-rays, MRIs and CT Scans

Warning: Device components including the Pod, Dexcom G6 Sensor, Dexcom G6 Transmitter, and FreeStyle Libre 2 Plus Sensor may be affected by strong radiation or magnetic fields. Device components must be removed (and the Pod and Sensor should be disposed of) before X-ray, Magnetic Resonance Imaging (MRI), or Computed Tomography (CT) scan (or any similar test or procedure). In addition, the Controller should be placed outside the procedure room. Exposure to X-ray, MRI or CT treatment can damage these components. Check with your healthcare provider on Pod removal guidelines.

The Pod and Controller can tolerate common electromagnetic and electrostatic fields, including airport security and mobile phones.

Surgery or Hospitalisation

For scheduled surgeries or hospitalisation, you should tell the doctor/surgeon or hospital staff about your Pod. It may be necessary to remove it for certain procedures or treatments. Remember to replace the basal insulin that was missed while the Pod was removed. Your healthcare provider can help you prepare for these situations.

SMARTBOLUS CALCULATOR

SmartBolus Calculator
Important Safety Information

- 16 Delivering a Bolus
- 17 Delivering a Bolus with the SmartBolus Calculator
- 18 SmartBolus Calculator Calculations



This page intentionally left blank.

SmartBolus Calculator Important Safety Information

SmartBolus Calculator Warnings

Warning: AVOID changing your SmartBolus Calculator settings before consulting with your healthcare provider. Incorrect changes could result in over-delivery or under-delivery of insulin, which can lead to hypoglycaemia or hyperglycaemia. Settings that impact bolus calculations mainly include: Max Bolus, Minimum Glucose for Calculations, Correct Above, Correction Factor(s), Insulin-to-Carb (IC) Ratio(s), Duration of Insulin Action and Target Glucose.

Warning: ALWAYS check your glucose frequently when you use the Extended Bolus function to avoid hypoglycaemia or hyperglycaemia.

Warning: AVOID entering a blood glucose reading that is older than 10 minutes. If you use a reading older than 10 minutes, the bolus calculator could calculate and recommend an incorrect dose, which could result in over-delivery or under-delivery of insulin. This can lead to hypoglycaemia or hyperglycaemia.

Warning: ALWAYS be aware of your current Sensor glucose value, trust how your body feels and do not ignore symptoms of high and low glucose. Even though insulin delivery adjusts automatically in Automated Mode, with the goal of bringing your glucose level to your defined Target Glucose, severe hypoglycaemia or hyperglycaemia may still occur.

If your Sensor glucose values do not match your symptoms, ALWAYS check your blood glucose using a BG meter and consider treatment and/or Sensor calibration if necessary. ALWAYS switch to Manual Mode if you feel you are receiving inaccurate Sensor glucose values.

- Erroneously high Sensor glucose values can cause excessive insulin delivery, leading to severe hypoglycaemia, seizure, loss of consciousness or death.
- Erroneously low Sensor glucose values can cause prolonged insulin suspension, leading to hyperglycaemia, DKA or death.

If you are having symptoms that are not consistent with your blood glucose readings and you have followed all instructions described in this *Technical User Guide*, contact your healthcare provider.

Important Safety Information

Warning: DO NOT use Omnipod 5 System with the Dexcom G6 Sensor if you are taking hydroxyurea, a medication used in the treatment of diseases including cancer and sickle cell anaemia. Your Dexcom G6 Sensor glucose values could be falsely elevated and could result in over-delivery of insulin, which can lead to severe hypoglycaemia.

SmartBolus Calculator Precautions

Caution: ALWAYS check your glucose prior to delivering a bolus so you are better informed on how much to take. Delivering a bolus without checking your glucose could result in over-delivery or under-delivery of insulin, which can lead to hypoglycaemia or hyperglycaemia.

Caution: DO NOT navigate away from the Omnipod 5 App while you are in the process of making changes to your insulin delivery settings. If you leave the App before you are able to save the setting change and before the App is able to put the setting change into effect, the system will continue to use your last saved settings. As a result, you may continue with therapy settings that you did not intend. If you are unsure about whether your changes were saved, review your settings.

CHAPTER 16

Delivering a Bolus

Contents

16.1 Delivering a Manual Bolus	212
16.2 Delivering Immediate and Extended Boluses	213
16.3 Tracking the Progress of a Bolus	214
Immediate bolus progress	214
Extended bolus progress	215
16.4 Canceling a Bolus in Progress	215
Cancel a bolus	216
Deliver a new bolus before an extended bolus has ended.....	216

16.1 Delivering a Manual Bolus

In certain situations, you may decide to deliver a manual bolus. A manual bolus is a bolus that you have calculated without the help of the SmartBolus Calculator. You can use manual boluses when the SmartBolus Calculator is temporarily disabled or when you choose not to use the SmartBolus Calculator. Consult your healthcare provider for instructions about how to calculate a bolus.

You can extend some or all of a manual bolus in Manual Mode.

When delivering a manual bolus, the Omnipod 5 System does not adjust the bolus amount based on your glucose value, carbohydrates being consumed or IOB as it does when the SmartBolus Calculator is used.

Note: Any bolus delivered by you will be considered as IOB and may impact automated insulin delivery in Automated Mode. Current glucose values will continue to be considered in Automated Mode and may impact automated insulin delivery.

A bolus cannot be greater than your Maximum Bolus setting. See “Maximum Bolus” on page 229.

To deliver a manual bolus:

1. On the Home screen, tap the Bolus button ().
2. Tap the Total Bolus field and enter the bolus amount.
3. Tap Done.
4. To deliver the entire bolus immediately, tap CONFIRM.
5. Review the bolus details on the Confirm Bolus screen.
6. Tap START to begin the bolus.

The bolus amount and bolus details are stored in your history records. The Home screen tracks the delivery of an immediate or Extended Bolus.

16.2 Delivering Immediate and Extended Boluses

A bolus is an extra dose of insulin that is delivered in addition to the continuous basal rate of insulin delivery. Use boluses to cover the carbohydrates in a meal and/or bring down high glucose.

You have the option of delivering the entire bolus at once. This is referred to as an “immediate bolus” or, simply, a “bolus.” In Manual Mode, you can also spread out the delivery of all or part of a meal bolus so that it is delivered steadily over a specified period of time. This is referred to as an “Extended Bolus.”

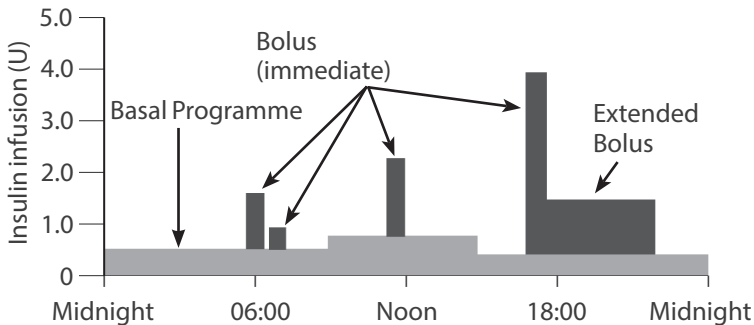

You may want to extend a bolus if your meal contains high-fat or high-protein foods. These foods slow down digestion and therefore slow down the post-meal rise in your glucose.

16.3 Tracking the Progress of a Bolus

During a bolus, the Home screen displays a progress bar.

Immediate bolus progress

During an immediate bolus, the Home screen displays a Delivering Bolus message along with a progress bar and details.

An estimate of the IOB is displayed in the lower left of the screen.

If IOB is unavailable, then the amount of the last completed bolus is displayed in the lower left of the screen.

Note: You cannot navigate within the Omnipod 5 App during an immediate bolus.

Note: Look for the progress bar to confirm the bolus delivery has started before navigating away from the Omnipod 5 App. To cancel a bolus, see “16.4 Canceling a Bolus in Progress” on page 215.

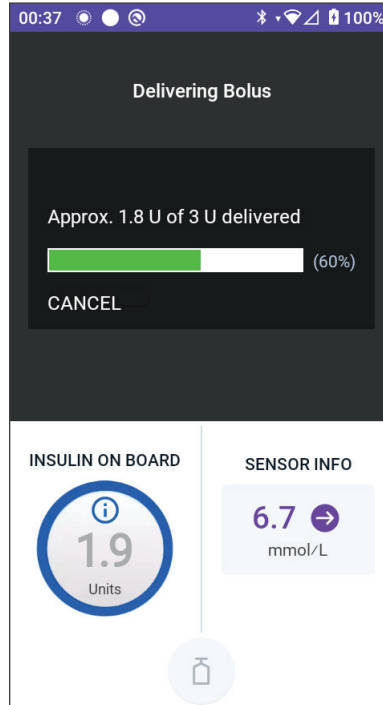

Extended bolus progress

During an Extended Bolus, the Home screen's DASHBOARD tab displays a Delivering Extended Bolus message along with a progress bar and other details.

An estimate of the IOB is displayed in the lower left of the screen.

If IOB is unavailable, then the amount of the last completed bolus is displayed in the lower left of the screen.

Note: You can still navigate within the Omnipod 5 App during an Extended Bolus but some functions will be unavailable until the bolus is complete.

Unless you cancel the bolus, the Pod will finish delivering a bolus whether or not it is in range of the Controller. To cancel a bolus, see “16.4 Canceling a Bolus in Progress” in the next section.

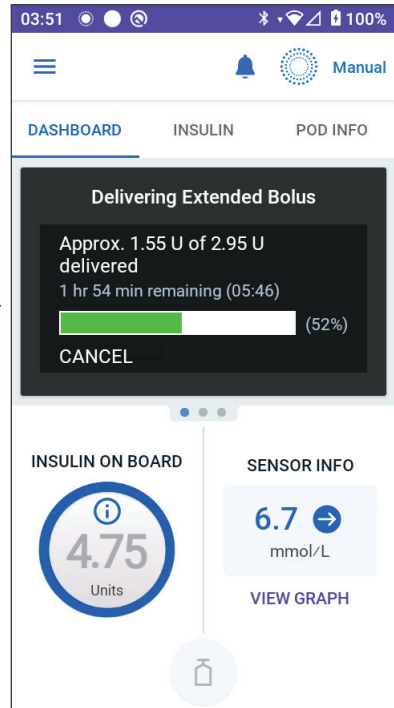

16.4 Canceling a Bolus in Progress

When an immediate bolus is in progress, you must cancel it or allow it to finish before performing any other action.

During an Extended Bolus, you can use your Omnipod 5 System normally, except that the Bolus button will be disabled (greyed out), preventing you from delivering an additional bolus. You have the options to:

- Cancel the bolus.
- Cancel the bolus in progress and then deliver another bolus.

If you get a communication error message when cancelling a bolus, see “Error when cancelling a bolus” on page 376.

16 Delivering a Bolus

Cancel a bolus

To cancel an immediate or Extended Bolus:

1. On the Home screen (immediate bolus) or the Home screen's DASHBOARD tab (Extended Bolus), tap CANCEL.
2. Tap YES to confirm cancelling the bolus. The Pod beeps to confirm that the bolus is cancelled.

Tip: To see how much insulin was delivered from a bolus, go to: Menu button (☰) > History Detail > Summary. For more information, see “Immediate and Extended Boluses” on page 141.

Deliver a new bolus before an extended bolus has ended

To deliver a bolus while an Extended Bolus is in progress:

1. Cancel the Extended Bolus as described in the previous procedure, “Cancel a bolus”.
2. Find out how much insulin was remaining (not delivered) from the cancelled bolus. You can find bolus details at Menu button (☰) > History Detail > Summary
3. From the Bolus screen, enter the carbs and glucose (or USE SENSOR) information.
4. Optional: take into consideration the amount remaining from the cancelled bolus and add the amount in the Total Bolus field.
5. Check if the amount entered in the Total Bolus field is correct. Then tap CONFIRM.
6. Tap START.

CHAPTER 17

Delivering a Bolus with the SmartBolus Calculator

Contents

17.1 About the SmartBolus Calculator	218
About Correction Boluses and Meal Boluses	218
About Using a Sensor Glucose Value with Trend	218
17.2 Entering Meal Information	220
17.3 Entering a Blood Glucose Reading or Using a Sensor Glucose Value	220
Manually Enter Your Blood Glucose Reading	220
Import and Use Sensor Glucose Value	221
17.4 Insulin on Board (IOB)	222
How IOB is calculated	222
IOB in the SmartBolus Calculator	222
17.5 Adjustments to Your Calculation	223
17.6 Delivering an Immediate Bolus	224
17.7 Delivering an Extended Bolus	225
17.8 Bolus Settings	227
Impacts on Suggested Bolus Calculations	227
Maximum Bolus	229
Extended Bolus	229
SmartBolus Calculator Settings	230
Target Glucose and Correct Above	230
Minimum Glucose for Calculations	230
Insulin-to-Carb Ratio (IC Ratio)	231
Correction Factor	231
Reverse Correction	232
Duration of Insulin Action	232

17.1 About the SmartBolus Calculator

A bolus is a dose of insulin taken to cover carbohydrates in a meal, drink or snack (a meal bolus) or to correct elevated glucose (a correction bolus). The SmartBolus Calculator calculates a suggested bolus amount of insulin to bring down high glucose (a correction bolus) and/or to cover carbohydrates in a meal (a meal bolus).

About Correction Boluses and Meal Boluses

If you enter a blood glucose reading or sensor glucose value that is above target, but enter no carbs, a correction bolus is calculated. If you enter carbs, but not a blood glucose reading or sensor glucose value, a meal bolus is calculated. If you enter both a blood glucose reading or sensor glucose value and carbs, both factors are used to calculate a suggested bolus.

Value Entered		Type of Bolus Calculated
Blood Glucose Reading or Sensor Glucose Value Above Target	Carbohydrates	
✓		Correction bolus
	✓	Meal bolus
✓	✓	Combined suggested bolus

About Using a Sensor Glucose Value with Trend

Your sensor glucose trend is based on the recent pattern of glucose changes. If you use your sensor glucose value, your sensor glucose value and trend will be used to calculate a suggested bolus amount. The sensor glucose value and trend will be used along with your Correction Factor to determine the correction portion of your bolus. The SmartBolus Calculator will use the sensor glucose trend to adjust the correction bolus amount.

When Sensor Glucose Values are...	The SmartBolus Calculator tries to keep glucose within target range and...
Trending up (increasing)	Adds more insulin to the bolus.
Trending down (decreasing)	Subtracts insulin from the bolus.
Steady	No adjustment to the bolus.

Additional information

You may choose to accept or change the final recommendation before the bolus is delivered.

After opening the SmartBolus Calculator, bolus delivery must be initiated within 5 minutes or values will need to be refreshed. If more than 5 minutes pass, you will see a message that values have expired. Tap CONTINUE to refresh the SmartBolus Calculator, then enter or use your current values.

To change your personal settings used by the SmartBolus Calculator, see “SmartBolus Calculator Settings” on page 230.

Note: To use the SmartBolus Calculator, the Omnipod 5 App and the Pod must be communicating. If there is no Omnipod 5 App to Pod communication, you will be prompted to re-establish a Pod connection. To find out what to do when your Omnipod 5 App and Pod have a communication issue, see “Frequently Asked Questions and Troubleshooting” on page 359.

Caution: DO NOT navigate away from the Omnipod 5 App while you are in the process of making changes to your insulin delivery settings. If you leave the App before you are able to save the setting change and before the App is able to put the setting change into effect, the system will continue to use your last saved settings. As a result, you may continue with therapy settings that you did not intend. If you are unsure about whether your changes were saved, review your settings.

Tip: If you already know the number of units for the bolus you want to deliver, tap Total Bolus. Enter the bolus amount and tap Done. Then go to page 224.

17.2 Entering Meal Information

To enter carbohydrates, or “carbs”, for your meal:

1. On the Home screen, tap the Bolus button ().
Note: The Bolus screen is only valid for 5 minutes. After 5 minutes, if bolus delivery has not started, you must refresh and re-enter new values.
2. Tap the Carbs field. Enter the grams of carbs and tap Done.
Note: Consult your healthcare provider about how to calculate the grams of carbs.
3. Review the suggested meal bolus, which is shown below the grams of carbs.
4. Optional: tap CALCULATIONS to see the details of the bolus calculations.

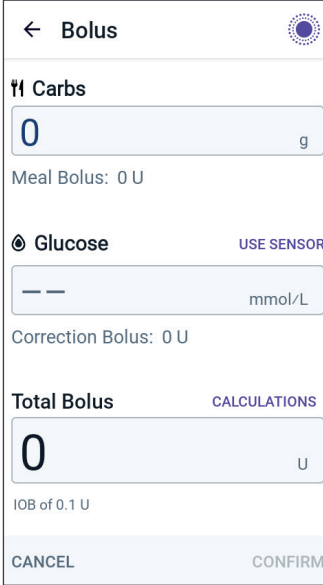

← Bolus 

Carbs

0 g

Meal Bolus: 0 U

Glucose USE SENSOR

-- mmol/L

Correction Bolus: 0 U

Total Bolus CALCULATIONS

0 U

IOB of 0.1 U

CANCEL CONFIRM

17.3 Entering a Blood Glucose Reading or Using a Sensor Glucose Value

The SmartBolus Calculator uses your glucose information to calculate a correction portion of your bolus. The following sections describe how to give the SmartBolus Calculator your glucose information by either manually entering a blood glucose reading or by obtaining and using the current sensor glucose value.

Note: The SmartBolus Calculator can generate a suggested bolus dose based on the carbohydrates in a meal and the blood glucose reading, or sensor glucose value with trend. Entering a recent blood glucose reading or using a sensor glucose value with trend can help with safety and accuracy.

Manually Enter Your Blood Glucose Reading

Warning: AVOID entering a blood glucose reading that is older than 10 minutes. If you use a reading older than 10 minutes, the bolus calculator could calculate and recommend an incorrect dose, which could result in over-delivery or under-delivery of insulin. This can lead to hypoglycaemia or hyperglycaemia.

To enter a blood glucose reading:

1. Tap the Glucose field.

If you have manually entered a blood glucose reading from a meter within the past 10 minutes, that value automatically appears in the Glucose field. If you want the SmartBolus Calculator to use that value, skip the next step.

2. Tap the box in the circle and enter the blood glucose reading. Alternatively, slide the indicator along the circle to enter the blood glucose reading.

For the meaning of the colours displayed on the Enter Glucose screen, see “How Blood Glucose Readings are Displayed” on page 115.

3. Tap ADD TO CALCULATOR. The SmartBolus Calculator screen appears.
4. Review the suggested correction bolus, which is shown below the blood glucose reading. The correction bolus has been adjusted for any Insulin on Board (IOB) (see “Insulin on Board (IOB)” on page 242).

Import and Use Sensor Glucose Value

Warning: ALWAYS be aware of your current sensor glucose value, trust how your body feels and do not ignore symptoms of high and low glucose. Even though insulin delivery adjusts automatically in Automated Mode, with the goal of bringing your glucose level to your defined Target Glucose, severe hypoglycaemia or hyperglycaemia may still occur.

If your sensor glucose values do not match your symptoms, ALWAYS check your blood glucose using a BG meter and consider treatment and/or sensor calibration if necessary. ALWAYS switch to Manual Mode if you feel you are receiving inaccurate sensor glucose values.

- Erroneously high sensor glucose values can cause excessive insulin delivery, leading to severe hypoglycaemia, seizure, loss of consciousness or death.
- Erroneously low sensor glucose values can cause prolonged insulin suspension, leading to hyperglycaemia, DKA or death.

If you are having symptoms that are not consistent with your blood glucose readings and you have followed all instructions described in this *Technical User Guide*, contact your healthcare provider.

If a Sensor is connected, you can use the current sensor glucose value and trend in both Manual and Automated Modes:

- Tap USE SENSOR.

17 Delivering a Bolus with the SmartBolus Calculator

If the current sensor glucose value is below the defined Minimum Glucose for Calculations setting, you will see a message that the SmartBolus Calculator is disabled. If the sensor glucose value displays “HIGH”, the SmartBolus Calculator is temporarily disabled.

Note: If your Omnipod 5 System does not have a valid sensor glucose value or trend at the time you open the SmartBolus Calculator, the USE SENSOR option is disabled.

Tip: If you want to replace the sensor glucose value with a blood glucose reading, tap the sensor field. See “Manually Enter Your Blood Glucose Reading” on page 220.

17.4 Insulin on Board (IOB)

Insulin on Board, also known as IOB or active insulin, is the amount of insulin that is still “active” in the body from a previous bolus or from automated insulin delivery.

How IOB is calculated

The Omnipod 5 System calculates IOB as any insulin (bolus or basal) delivered above the Adaptive Basal Rate that you would expect the System to have delivered in Automated Mode during that time.

Note: If you see IOB tracked in Manual Mode that you cannot account for from a previous bolus, it is likely that your Manual Mode Basal Programme was delivering a Basal Rate that was higher than your Automated Mode Adaptive Basal Rate for a period of time.

Note: Your programmed Duration of Insulin Action is used to calculate bolus insulin IOB only. SmartAdjust technology uses its own action time to calculate IOB from insulin above the Adaptive Basal Rate.

IOB in the SmartBolus Calculator

The SmartBolus Calculator considers the current IOB when calculating a suggested bolus. Insulin on Board may come from:

- Meal IOB - from previous meal boluses.
- Correction IOB - can be from previous correction boluses or from automated insulin deliveries above the Adaptive Basal Rate.

For more information, see “Insulin on Board (IOB)” on page 242 and “SmartBolus Calculator Equations” on page 244.

In certain circumstances you may decide to enter only carbs or the bolus amount into the SmartBolus Calculator. This may be desired if you only want to bolus for carbs using your programmed Insulin-to-Carbohydrate Ratio, or you want to deliver an amount of insulin based on your own estimate. If entering only carbs or a bolus amount without a glucose value, IOB is not subtracted from your suggested bolus dose as the calculator is not able to adjust the bolus dose if your glucose value is not known. If you want IOB to be considered, enter a glucose value. Here is an example to demonstrate when you may choose to enter only the carb or bolus amount into the SmartBolus Calculator.

Example: You are about to have lunch and you are not sure how much you will eat. To avoid taking too much insulin, you deliver a meal and correction bolus based on the carbs you know you will eat and your glucose value. After delivering the bolus and eating the first portion, you decide you want to finish the remaining portion. Since you already delivered a correction with the previous bolus, and you know glucose values are on the rise, you decide to deliver a second bolus for only the remaining carbs in your meal and not enter another glucose value.

17.5 Adjustments to Your Calculation

A suggested meal bolus that is calculated using your Insulin-to-Carb (IC) Ratio may be further adjusted for other values entered into and used by the SmartBolus Calculator, including: blood glucose readings, sensor glucose value and trend, and/or IOB. These adjustments can be for the following:

- Insulin on Board — either meal or correction IOB.
- Reverse Correction, if this feature is turned ON and your glucose is below your Target Glucose.
- Blood glucose reading, if manually entered.
- Sensor glucose value and trend (see “19.5 Sensor Glucose Trend Arrows” on page 260).

17 Delivering a Bolus with the SmartBolus Calculator

17.6 Delivering an Immediate Bolus

The Total Bolus field shows the proposed bolus. The amount of any IOB adjustment appears below the Total Bolus field.

Note: The EXTEND BOLUS option is available during meal bolus entry when the system is in Manual Mode and the Extended Bolus setting is ON.

To review and deliver the immediate bolus:

1. Review the suggested bolus.
 - To adjust it, tap the Total Bolus field and enter a revised bolus.
2. To review the specifics of calculations, tap CALCULATIONS. You may need to swipe up or down to see all of the calculations. Tap CLOSE when done. See “SmartBolus Calculator Settings” on page 230 for details.
3. To deliver the entire bolus immediately, tap CONFIRM.
4. Review the bolus details on the Confirm Bolus screen.
5. Optional: Set up a Reminder to check your glucose:
 - a. Tap CREATE BG REMINDER.
 - b. Tap the Check BG in field and select the number of hours you want to be reminded in.
 - c. Tap SAVE.
6. Review the bolus details on the Confirm Bolus screen.

The total bolus includes any IOB adjustments and any adjustments you made to the calculated bolus.

The screenshot shows the 'Confirm Bolus' screen. At the top left is a back arrow and the title 'Confirm Bolus'. At the top right is a gear icon for settings. Below the title, there are two input fields: 'Carbs' with a fork and knife icon and a value of '27 g', and 'Glucose' with a glucose icon and a value of '6.7 mmol/L'. Below these is a large white box containing the 'Total Bolus' of '2.75 U'. Underneath the total bolus, it says 'CALCULATIONS' and 'Adjusted for IOB of 0.15 U'. At the bottom of the screen are two buttons: a large purple 'START' button and a smaller white 'CANCEL' button.

Grams of carbs
Blood glucose or sensor glucose value

Adjusted for IOB of x U means the SmartBolus Calculator took IOB into account.

7. Tap START to begin the bolus.

The Home screen tracks the delivery of an immediate or Extended Bolus (see “16.3 Tracking the Progress of a Bolus” on page 214).

17.7 Delivering an Extended Bolus

Warning: ALWAYS check your glucose frequently when you use the Extended Bolus function to avoid hypoglycaemia or hyperglycaemia.

Note: You can extend a bolus only while in Manual Mode.

To review, extend and deliver the bolus:

1. Review the suggested bolus.
 - a. To adjust it, tap the Total Bolus field and enter a revised bolus.
2. To review the specifics of calculations, tap CALCULATIONS. You may need to swipe up or down to see all of the calculations. Tap CLOSE when done. See “SmartBolus Calculator Equations” on page 244 for details.
3. Tap EXTEND BOLUS.
4. Tap the Now field and enter the percentage of the bolus to be delivered immediately. Alternatively, tap the Extended field and enter the percentage to be extended.

The screenshot shows the 'Extended Bolus' interface. At the top, there is a back arrow and the title 'Extended Bolus' with a refresh icon. Below the title, there are two columns: 'Now' and 'Extended'. The 'Now' field contains '50' with a percentage sign and '1.45 U' below it. The 'Extended' field contains '50' with a percentage sign and '1.5 U' below it. A 'Duration' section is highlighted in light blue, with the label '(0.5 to 8 hrs)' and a text input field containing '2' and 'hrs'. Below this, a summary section shows 'Total Bolus' as '2.95 U', 'Meal Bolus' as '2.95 U', and 'Correction Bolus' as '0 U'. At the bottom, there are 'CANCEL' and 'CONFIRM' buttons.

The number of units to be delivered now and over the extended period appear below the percentage (%).

Note: You can extend only the meal portion of the bolus. A correction portion of the bolus, if any, is always delivered immediately.

5. Tap the Duration field and enter the duration for the extended portion of the bolus.
6. Tap CONFIRM.

The Extended Bolus screen shows how much of the bolus will be delivered immediately and how much will be extended.

17 Delivering a Bolus with the SmartBolus Calculator

7. Review the bolus details on the Confirm Bolus screen.

The screenshot shows the 'Confirm Bolus' screen with the following data:

- Carbs: 27 g
- Glucose (03:44): 9.6 mmol/L
- Bolus Now: 50% (Meal: 1.45 U)
- Bolus Extended: 50% (2 hrs) (Meal: 1.5 U)
- Total Bolus: 2.95 U
- Adjusted for IOB of 1.9 U

Annotations on the screen:

- An arrow points from the text "The entire correction bolus is delivered immediately." to the "Bolus Now" section.
- An arrow points from the text "Only the meal bolus can be extended." to the "Meal: 1.5 U" value under "Bolus Extended".
- An arrow points from the text "% of meal bolus to be given immediately" to the "50%" value under "Bolus Now".
- An arrow points from the text "% of meal bolus to be given over the extended period" to the "50% (2 hrs)" value under "Bolus Extended".

8. Review the bolus details, then tap START to begin the bolus.

17.8 Bolus Settings

Warning: DO NOT start to use your system or change your settings without adequate training and guidance from your healthcare provider. Initiating and adjusting settings incorrectly can result in over-delivery or under-delivery of insulin, which could lead to hypoglycaemia or hyperglycaemia. Settings that impact insulin delivery mainly include: Pod Shut-Off, basal rate(s), Max Basal Rate, Max Bolus, Correction Factor(s), Insulin-to-Carb (IC) Ratio(s), Minimum Glucose for Calculations, Target Glucose and Correct Above, and Duration of Insulin Action.

These settings allow you to change your Maximum Bolus, Extended Bolus and SmartBolus Calculator settings.

Impacts on Suggested Bolus Calculations

The following table describes what each SmartBolus Calculator setting does, how you can adjust them and how they are used to calculate a suggested bolus.

Omnipod 5 Setting and Range	How to Enter the Setting	Impacts on Suggested Bolus Calculations
Carbs (grams) 0.1–225 g (0.1 g increments)	Enter in SmartBolus Calculator	Increase in carb amount value increases amount of suggested bolus dose. Decrease in carb amount value decreases amount of suggested bolus dose.
Sensor Glucose Value (mmol/L) Dexcom G6: 2.2–22.2 mmol/L (40–400 mg/dL) FreeStyle Libre 2 Plus: 2.2–27.8 mmol/L (40–500 mg/dL) (0.1 mmol/L or 1 mg/dL increments)	Select USE Sensor within SmartBolus Calculator (Value comes from your connected Sensor)	Increase in sensor glucose value increases amount of suggested bolus dose. Decrease in sensor glucose value decreases amount of suggested bolus dose.

17 Delivering a Bolus with the SmartBolus Calculator

Omnipod 5 Setting and Range	How to Enter the Setting	Impacts on Suggested Bolus Calculations
Blood Glucose Reading (mmol/L) 1.1–33.3 mmol/L (20–600 mg/dL) (0.1 mmol/L or 1 mg/dL increments)	Enter in SmartBolus Calculator (Value comes from your blood glucose meter)	Increase in BG Reading increases amount of suggested bolus dose. Decrease in BG Reading decreases amount of suggested bolus dose.
Maximum Bolus 0.05–30 U (0.05 U increments)	Enter in Omnipod 5 App Settings or during First Time Setup	Limits amount of single bolus dose.
Extended Bolus (Manual Mode only) ON/OFF	Enter in Omnipod 5 App Settings or during First-Time Setup	Allows for bolus delivery over a user-selected period of time .
Target Glucose & Correct Above Target Glucose: 6.1–8.3 mmol/L (110–150 mg/dL) Correct Above: Target Glucose to 11.1 mmol/L (200 mg/dL) (0.55 mmol/L or 10 mg/dL increments, up to 8 segments/day)	Enter in Omnipod 5 App Settings or during First-Time Setup	Increase in setting value decreases amount of suggested bolus dose. Decrease in setting value increases amount of suggested bolus dose.
Minimum Glucose for Calculations 2.8–3.9 mmol/L (50–70 mg/dL) (0.1 mmol/L or 1 mg/dL increments)	Enter in Omnipod 5 App Settings	Disables SmartBolus Calculator when glucose is at or below setting value.
Insulin-to-Carb Ratio 1–150 g (0.1 mmol/L or 1 mg/dL increments, up to 8 segments/day)	Enter in Omnipod 5 App Settings or during First-Time Setup	Increase in setting value decreases amount of suggested bolus dose. Decrease in setting value increases amount of suggested bolus dose.

Omnipod 5 Setting and Range	How to Enter the Setting	Impacts on Suggested Bolus Calculations
Correction Factor 0.1–22.2 mmol/L (1–400 mg/dL) (0.1 mmol/L increments, up to 8 segments/day)	Enter in Omnipod 5 App Settings or during First-Time Setup	Increase in setting value decreases amount of suggested bolus dose. Decrease in setting value increases amount of suggested bolus dose.
Reverse Correction ON/OFF	Enter in Omnipod 5 App Settings	If “On,” suggested bolus is decreased when glucose is below Target Glucose value.
Duration of Insulin Action 2–6 hours (0.5 hour increments)	Enter in Omnipod 5 App Settings or during First-Time Setup	Increase in setting value may decrease amount of suggested bolus dose for longer periods.

Note: The Extended Bolus feature can only be used in Manual Mode. All other therapy settings are used similarly in both Manual and Automated Modes.

Maximum Bolus

The Maximum Bolus setting defines the upper limit for a bolus. The SmartBolus Calculator prevents you from entering a bolus over this amount. It also prevents you from entering a carb amount that will cause your calculated bolus to exceed this amount. The largest allowed value of the Maximum Bolus is 30 units.

To change your Maximum Bolus:

1. Navigate to: Menu button () > Settings > Bolus > Maximum Bolus.
2. Tap the Max Bolus field and enter the new Maximum Bolus value.
3. Tap SAVE.

Extended Bolus

An Extended Bolus is delivered over a user-specified period of time. Only the meal portion of a bolus can be extended. A correction bolus cannot be extended. To turn OFF the Extended Bolus feature or to change your Extended Bolus configuration:

1. Navigate to: Menu button () > Settings > Bolus.

17 Delivering a Bolus with the SmartBolus Calculator

2. Tap the toggle next to Extended Bolus to turn ON or OFF the ability to extend a bolus.

SmartBolus Calculator Settings

This section describes how to adjust the settings used by the SmartBolus Calculator to calculate meal and correction boluses.

Tip: Write a list of all of the desired settings and segments to guide you through re-entering the values for each segment.

Target Glucose and Correct Above

In both Automated and Manual Mode, the SmartBolus Calculator aims to bring your glucose to your Target Glucose. However, the SmartBolus Calculator only calculates a correction bolus if your glucose is above your Correct Above setting. In Automated Mode, the Omnipod 5 System will adjust your automated insulin delivery with the goal of bringing you to your Target Glucose.

To edit Target Glucose or Correct Above values:

1. Navigate to: Menu button (☰) > Settings > Bolus > Target Glucose & Correct Above.
2. Tap NEXT.
3. To edit a segment, tap the row containing the segment you want to edit.
 - a. Tap the EndTime field to enter a new end time.
 - b. Tap the Target Glucose field to enter a new Target Glucose.
 - c. Tap the Correct Above field to enter a new Correct Above value.
 - d. Tap NEXT.
4. Repeat the previous step as needed for the remaining segments.
5. After confirming that all segments are correct, tap SAVE.

Note: You can add and delete segments by editing the existing segments.

Minimum Glucose for Calculations

Your Minimum Glucose for Calculations is used to prevent you from delivering a bolus when your glucose is too low. If your glucose is below your Minimum Glucose for Calculations, the SmartBolus Calculator is disabled and does not calculate a bolus. To edit this value:

1. Navigate to: Menu button (☰) > Settings > Bolus > Minimum Glucose for Calculations.

2. Tap the Minimum Glucose for Calculations field and enter the desired value.
3. Tap SAVE.

Insulin-to-Carb Ratio (IC Ratio)

The Insulin-to-Carbohydrate Ratio (IC Ratio) defines how many grams of carbohydrate are covered by one unit of insulin. The SmartBolus Calculator uses your IC Ratio to calculate a meal bolus when you are going to eat. To edit this value:

1. Navigate to: Menu button () > Settings > Bolus > Insulin-to-Carb Ratio.
2. Tap NEXT.
3. To edit a segment, tap the row containing the segment you want to edit.
 - a. Tap the EndTime field to enter a new end time.
 - b. Tap the 1 Unit of Insulin Covers field and enter a new IC Ratio.
 - c. Tap NEXT.
4. Repeat the previous step as needed for the remaining segments.
5. After confirming that all segments are correct, tap SAVE.

Note: You can add and delete segments by editing the existing segments.

Correction Factor

The SmartBolus Calculator uses your Correction Factor to calculate a correction bolus when your glucose is above your Correct Above setting. See “Target Glucose and Correct Above” on page 230. To edit this value:

1. Navigate to: Menu button () > Settings > Bolus > Correction Factor.
2. Tap NEXT.
3. To edit a segment, tap the row containing the segment you want to edit.
 - a. Tap the EndTime field to enter a new end time.
 - b. Tap the 1 Unit of Insulin lowers glucose by field and enter a new Correction Factor.
 - c. Tap NEXT.
4. Repeat the previous step as needed for the remaining segments.
5. After confirming that all segments are correct, tap SAVE.

Note: You can add and delete segments by editing the existing segments.

Reverse Correction

The Reverse Correction setting determines how the SmartBolus Calculator handles meal boluses when your glucose is below your Target Glucose.

To turn Reverse Correction ON or OFF:

1. Navigate to: Menu button () > Settings > Bolus.
2. Tap the toggle on the Reverse Correction line to turn it ON or OFF.

Duration of Insulin Action

The SmartBolus Calculator uses your Duration of Insulin Action setting to calculate the amount of Insulin on Board (IOB) from a previous bolus. To edit this value:

1. Navigate to:
Menu button () > Settings > Bolus > Duration of Insulin Action
2. Tap the Duration of Insulin Action field and enter the new value.
3. Tap SAVE.

Note: While in Automated Mode, SmartAdjust technology does not use this Duration of Insulin Action setting to calculate automated basal insulin delivery. See “17.4 Insulin on Board (IOB)” on page 222.

CHAPTER 18

Understanding SmartBolus Calculator Calculations

Contents

18.1 The SmartBolus Calculator	234
SmartBolus Calculator Boluses	234
Extended boluses	234
Maximum Bolus	234
Controlling the bolus amount	234
When the SmartBolus Calculator Does Not Work	235
Factors Used in the SmartBolus Calculator Calculations	235
Sensor glucose trend	236
Target Glucose	236
Correct Above threshold	236
Insulin on board	236
Duration of Insulin Action	236
Minimum Glucose for Calculations	237
Reverse Correction	237
Boundaries of the SmartBolus Calculator suggestions	240
Considerations about SmartBolus Calculator Recommendations	241
Insulin on Board (IOB)	242
Bolus IOB depletion	243
SmartBolus Calculator Equations	244
SmartBolus Calculator Rules	246
Overview of the Bolus Calculations Screen	247
18.2 SmartBolus Calculator Examples	248

18.1 The SmartBolus Calculator

Your Omnipod 5 System's SmartBolus Calculator can do a lot of the work of calculating a bolus for you. The SmartBolus Calculator uses your personal settings and also takes into account any insulin that remains (referred to as Insulin on Board or IOB) from automated insulin delivery and from recent boluses.

SmartBolus Calculator Boluses

When calculating a bolus, the SmartBolus Calculator considers a bolus to be made up of the following two components:

- **Correction bolus:** Used to lower glucose when it gets too high.
- **Meal bolus:** Used to cover carbs in a meal.

Extended boluses

When using the SmartBolus Calculator, you can extend some or all of a meal bolus in Manual Mode, but a correction bolus cannot be extended. A correction bolus is always delivered immediately. In the following example, three units of insulin are extended:

Total bolus = 5 units (1 unit correction bolus + 4 units meal bolus)

└─▶ Deliver now = 2 units (1 unit correction + 1 unit meal bolus)
└─▶ Extend = 3 units (3 units meal bolus)

Maximum Bolus

The Omnipod 5 System does not allow you to enter a bolus that is above your Maximum Bolus setting. If the SmartBolus Calculator calculates a bolus amount greater than your Maximum Bolus, you will only be able to deliver up to the Maximum Bolus amount. To adjust it, tap the Total Bolus field and enter a revised bolus.

Controlling the bolus amount

The SmartBolus Calculator is a useful tool, but you have the ultimate control over the amount of a bolus to be delivered. After the SmartBolus Calculator suggests a bolus amount, you can confirm the suggested bolus or increase or decrease it. Always check the Calculations to confirm the amount of insulin before it is delivered.

When the SmartBolus Calculator Does Not Work

The SmartBolus Calculator does not work when it is disabled or when there is no Pod communication. Being “disabled” means that the SmartBolus Calculator is temporarily unable to calculate a suggested bolus. Your Omnipod 5 System may disable the SmartBolus Calculator in a few situations.

Conditions that disable the SmartBolus Calculator:	The SmartBolus Calculator is disabled until:	While the SmartBolus Calculator is disabled:
Your glucose is below your Minimum Glucose for Calculations setting.	Ten minutes pass. or A new glucose reading is above your Minimum Glucose for Calculations setting.	IOB is displayed on the Home screen.
Your manually entered blood glucose reading is greater than 33.3 mmol/L (600 mg/dL) or “HIGH.”	Ten minutes pass. or A new blood glucose reading is lower than “HIGH.”	IOB is displayed on the Home screen.
There is an unconfirmed bolus when you discard a Pod.	A complete Duration of Insulin Action period passes. For example, if your Duration of Insulin Action is set at “2 hours” and you receive an unconfirmed bolus at 08:00, you will be unable to use the SmartBolus Calculator until 10:00 (2 hours after the unconfirmed bolus).	IOB is not displayed on the Home screen.

Factors Used in the SmartBolus Calculator Calculations

The SmartBolus Calculator accounts for the following when it calculates a bolus:

- Your current glucose (manually entered or from Sensor), sensor glucose trend (if sensor glucose value is used), Target Glucose, Correct Above threshold, and Correction Factor.
- The carbs you are about to eat or drink and your IC Ratio.
- Your Duration of Insulin Action and Insulin on Board (IOB).

18 Understanding SmartBolus Calculator Calculations

- Your Minimum Glucose for Calculations.
- Reverse Correction, if it is enabled.

Note: In both Automated and Manual Mode, if using a sensor glucose value and trend in the Calculator, the SmartBolus Calculator may reduce the suggested insulin dose, even if your Reverse Correction setting is OFF.

Sensor glucose trend

The sensor glucose trend is used to suggest up to 30% more correction insulin when your values are rapidly rising, or up to 100% less correction insulin when your values are rapidly falling, compared with the bolus amount suggested with just a blood glucose reading alone.

Target Glucose

When calculating a correction bolus, the SmartBolus Calculator aims to bring your glucose down to your Target Glucose.

Correct Above threshold

The SmartBolus Calculator only suggests a correction bolus if your glucose is above your Correct Above setting. This feature can prevent corrections to glucose that is only slightly higher than your Target Glucose.

Insulin on board

Insulin on Board (IOB) is the amount of insulin still active in your body from basal insulin delivery and from earlier boluses. IOB from previous correction boluses is referred to as correction IOB. IOB from previous meal boluses is referred to as meal IOB. Additionally, in Manual or Automated Modes, the Omnipod 5 algorithm constantly calculates IOB from your basal delivery above the Adaptive Basal Rate.

When calculating a new bolus, the SmartBolus Calculator may reduce the suggested bolus based on the IOB.

Note: The SmartBolus Calculator only subtracts IOB from a suggested bolus if your current glucose is known. You should always check your glucose prior to delivering a bolus.

For more about Insulin on Board, see “How IOB is calculated” on page 222.

Duration of Insulin Action

The SmartBolus Calculator uses your Duration of Insulin Action setting to calculate the Insulin on Board from prior boluses.

The Duration of Insulin Action setting represents the amount of time that insulin remains “on board” or “active” in your body.

Minimum Glucose for Calculations

The SmartBolus Calculator does not suggest a bolus if your glucose is below your Minimum Glucose for Calculations level. You can adjust this level down to 2.8 mmol/L (50 mg/dL).

Reverse Correction

If the Reverse Correction setting is turned ON and your glucose is below your Target Glucose, the SmartBolus Calculator reduces the meal bolus. This allows part of the meal to be used to raise the glucose towards the Target Glucose.

If the Reverse Correction setting is turned OFF, the SmartBolus Calculator suggests the full meal bolus even if your glucose is below your Target Glucose.

Note: In Automated Mode, if using a sensor glucose value and trend in the Calculator, the SmartBolus Calculator may subtract insulin even if your Reverse Correction setting is OFF in situations with a decreasing sensor glucose trend.

The below table shows how each value is used in the SmartBolus Calculator to calculate the total bolus volume:

	Accepted Value	How does the SmartBolus Calculator use this value?
Using Omnipod 5 System with a CE-marked Blood Glucose Meter		
Blood Glucose Reading from a BG Meter	1.1–33.3 mmol/L (20–600 mg/dL)	To calculate total bolus volume. You can enter a blood glucose reading directly into the SmartBolus Calculator. If 5 or more minutes have passed since entering the reading, it will expire. A reading saved to the Omnipod 5 System history may be used for up to 10 minutes after entry.
Omnipod 5 Insulin Pump		
Minimum Glucose for Calculations	2.8–3.9 mmol/L (50–70 mg/dL)	Disables bolus delivery when glucose is below this value. You can adjust this value in your Omnipod 5 System settings.
Correction Factor	0.1–22.2 mmol/L (1–400 mg/dL)	To calculate total bolus volume. You can adjust this value in your Omnipod 5 System settings. The value indicates how much one unit of insulin will lower your blood glucose.

18 Understanding SmartBolus Calculator Calculations

	Accepted Value	How does the SmartBolus Calculator use this value?
Correct Above	Target Glucose to 11.1 mmol/L (200 mg/dL)	To calculate total bolus volume. You can adjust this value in your Omnipod 5 System settings. The value indicates the minimum glucose at which a Correction Bolus will be included in the total bolus volume.
Carbohydrates	0.1–225 grams	To calculate total bolus volume. You can enter your Carbohydrates value directly into the calculator to inform the Meal Bolus.
Insulin-to-Carb Ratio	1–150 grams	To calculate total bolus volume. You can adjust this value in your Omnipod 5 System settings. The value indicates the grams of carbohydrate covered by one unit of insulin.
Duration of Insulin Action	2–6 hours	To calculate total bolus volume. You can adjust this value in your Omnipod 5 System settings. The value indicates how long insulin remains in effect after the bolus has been delivered.
Meal IOB Portion	0–X Units	To calculate total bolus volume. The value is known by the Omnipod 5 System and used by the Calculator to indicate any previously delivered Meal Boluses that may still be in effect.
Target Glucose	6.1–8.3 mmol/L (110–150 mg/dL)	To calculate total bolus volume. You can adjust this value in your Omnipod 5 System settings. In Automated Mode, basal insulin delivery will be adjusted automatically to bring you towards your Target Glucose. The value informs the Correction Bolus volume.

	Accepted Value	How does the SmartBolus Calculator use this value?
SmartAdjust™ technology (Automated Mode)		
Target Glucose	6.1–8.3 mmol/L (110–150 mg/dL)	To calculate total bolus volume. You can adjust this value in your Omnipod 5 System settings. In Automated Mode, basal insulin delivery will be adjusted automatically to bring you towards your Target Glucose. The value informs the Correction Bolus volume.
Correction IOB Portion	0–X Units	To calculate total bolus volume. This value is known by the Omnipod 5 System and used by the Bolus Calculator to indicate any previously delivered Correction Boluses that may still be in effect.
Using Omnipod 5 with a compatible Sensor		
Sensor Glucose Value	Dexcom G6: 2.2–22.2 mmol/L (40–400 mg/dL) FreeStyle Libre 2 Plus: 2.2–27.8 mmol/L (40–500 mg/dL)	To calculate total bolus volume. If you choose to use a Sensor, you can select USE Sensor directly in the Bolus Calculator. As a safety constraint, the Calculator will only accept sensor glucose values that are on trend with previous sensor glucose values.

18 Understanding SmartBolus Calculator Calculations

Boundaries of the SmartBolus Calculator suggestions

The following figure shows the boundaries between the types of calculations performed by the SmartBolus Calculator depending on your glucose. Some examples of how to read the figure are provided below:

- When your glucose is between your Target Glucose and your Correct Above, the SmartBolus Calculator calculates a meal bolus only.
- When your Sensor glucose value is over 22.2 mmol/L (400 mg/dL) for Dexcom G6 or 27.8 mmol/L (500 mg/dL) for FreeStyle Libre 2 Plus, the value is recorded as “HIGH” and cannot be used for bolusing.
- When your blood glucose reading is above 33.3 mmol/L (600 mg/dL) the reading is recorded as “HIGH” and the SmartBolus Calculator is disabled.

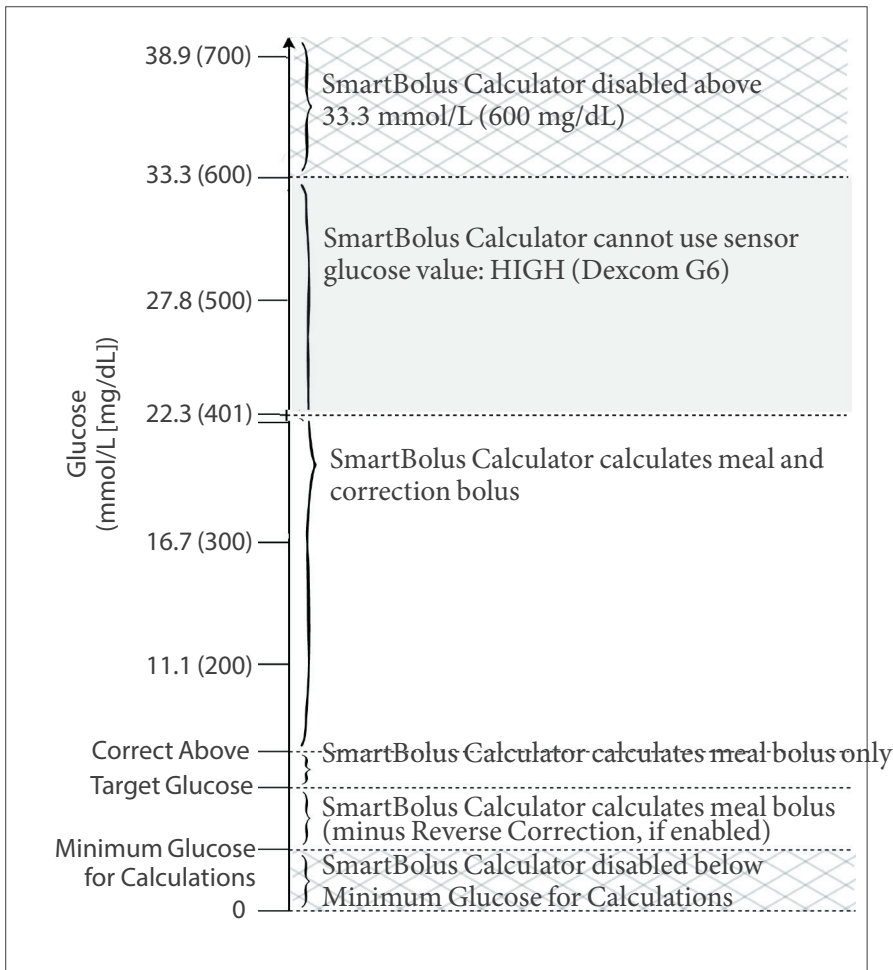

Considerations about SmartBolus Calculator Recommendations

Keep the following in mind when using the SmartBolus Calculator and reviewing its recommendations:

- The SmartBolus Calculator uses your SmartBolus Calculator settings for the time you are requesting a bolus (See “SmartBolus Calculator Settings” on page 230).
- The SmartBolus Calculator refreshes values every 5 minutes. If you do not start your bolus within 5 minutes of entering the SmartBolus Calculator, the Omnipod 5 System will need to clear the screen so that it has the latest IOB and Sensor information.
- When changing time zones, always check your IC Ratio and Correction Factor settings for the new time to ensure it still meets your body’s true insulin needs.
- The SmartBolus Calculator will suggest doses depending on the carbs you enter and the glucose value at that time. Check the nutritional content of your meals to ensure the carbs entered is as accurate as possible. Only enter BG readings that have been obtained within the last 10 minutes or tap USE SENSOR. These factors will make sure that the SmartBolus Calculator suggests a bolus dose that is suitable for you.

If your sensor glucose value or trend does not match your symptoms or expectations, use a fingerstick blood glucose reading in the SmartBolus Calculator.

When programming and delivering boluses, always confirm that the values you enter and the suggested bolus dose you receive are what you intend and align with what you want at that time. The Omnipod 5 System has features that help with preventing unintended delivery amounts.

Delivery Limitations	Description
Maximum Bolus Setting	The SmartBolus Calculator will not deliver boluses that exceed the Maximum Bolus Setting you entered (0.05 -30 U). For example, if you rarely deliver more than 5 U boluses, and you set the Maximum Bolus Setting at 5 U, the system will prevent you from delivering anything greater than this amount.

18 Understanding SmartBolus Calculator Calculations

Delivery Limitations	Description
Blood Glucose Reading Time-Out	The SmartBolus Calculator will not calculate a suggested bolus dose using a blood glucose reading you entered from the Main Menu (≡) that is older than 10 minutes. You will need to enter a more recent blood glucose reading within the SmartBolus Calculator.
SmartBolus Calculator Time-Out	The SmartBolus Calculator considers the values you input for a given bolus calculation valid for up to 5 minutes from initial entry of the value into the SmartBolus Calculator. If 5 minutes or more have elapsed, you will be notified that you must refresh the SmartBolus Calculator and input the values again.
Time Zones	The SmartBolus Calculator relies on accurate, updated insulin delivery history and data logging from your Omnipod 5 System. If a time zone change is detected by the Controller, the system will notify you. Update time zones on your Omnipod 5 App according to your healthcare provider's guidance.

Insulin on Board (IOB)

After a bolus is delivered, the amount of insulin that is active in the body decreases over several hours. The IOB from a bolus decreases based on your defined Duration of Insulin Action value within your profile settings.

You may also have IOB from insulin delivered from automation. SmartAdjust technology uses its own action time for insulin delivered above your Adaptive Basal Rate.

When using the SmartBolus Calculator, your Omnipod 5 System may, due to IOB, decrease your suggested bolus amount to help prevent giving too much insulin.

Note: You must bring your Controller near the Pod to get the most recent IOB value on your Omnipod 5 App Home screen.

Bolus IOB depletion

The graph below shows the IOB from an 8-unit bolus depleting over the set Duration of Insulin Action of 4 hours.

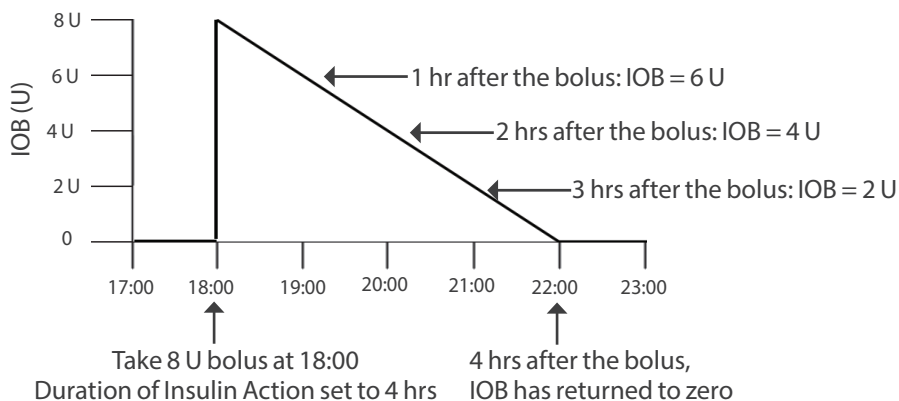

In the Omnipod 5 System, the correction IOB can also change depending on the SmartAdjust technology calculations. It can increase or decrease automatically.

Insulin on Board (IOB) calculations

$\frac{\text{Duration of Insulin Action} - \text{time since previous bolus}}{\text{Duration of Insulin Action}} \times \text{previous bolus}$

IOB from a previous correction bolus is called a “correction IOB.”

IOB from a previous meal bolus is called a “meal IOB”.

Correction IOB example

Duration of Insulin Action: 3 hours

Time since previous correction bolus: 1 hour

Previous correction bolus: 3 U

$$\frac{3 \text{ hours} - 1 \text{ hour}}{3 \text{ hours}} \times 3 \text{ U} = 2 \text{ U correction IOB}$$

Final IOB shown to you:

$$2 \text{ U correction IOB} + 1 \text{ U automatic adjustment} = 3 \text{ U overall IOB}$$

In other words, one hour after your previous correction bolus, your body has used up 1 unit from the correction bolus. The remaining 2 units of insulin are still working in your body to lower glucose. Additionally, the system can automatically adjust the correction IOB based on its estimate of your insulin needs. In this example, the automatic adjustment added 1 unit for a total of 3 units working to lower your glucose.

18 Understanding SmartBolus Calculator Calculations

Correction Meal IOB example

Duration of Insulin Action: 3 hours
Time since previous meal bolus: 2 hours
Previous meal bolus: 4.5 U

$$\frac{3 \text{ hours} - 2 \text{ hours}}{3 \text{ hours}} \times 4.5 \text{ U} = 1.5 \text{ U meal IOB}$$

In other words, two hours after your previous meal bolus, your body has used up 3 units from the meal bolus. The remaining 1.5 units of insulin are still in your body, working to cover your meal.

SmartBolus Calculator Equations

The SmartBolus Calculator first calculates a preliminary correction and meal bolus. It adjusts these values for IOB, if necessary. It then suggests a final total bolus that includes the adjusted correction bolus and meal bolus.

Note: Your adjustments from the sensor glucose trend can add or subtract insulin from the correction and/or the meal portion.

$$\text{Preliminary correction bolus} = \frac{\text{Current BG or Sensor} - \text{Target Glucose}}{\text{Correction Factor}}$$

Example: Current BG or Sensor: 11.1 mmol/L (200 mg/dL), Target Glucose:
8.3 mmol/L (150 mg/dL)
Correction Factor (CF): 2.8 (50)

$$\frac{11.1 \text{ mmol/L (200 mg/dL)} - 8.3 \text{ mmol/L (150 mg/dL)}}{2.8 (50)} = 1 \text{ U prelim. correction bolus}$$

$$\text{Preliminary meal bolus} = \frac{\text{Carb intake}}{\text{Insulin-to-Carb (IC) Ratio}}$$

Example: Carb intake: 45 grams of carb, IC Ratio: 15

$$\frac{45}{15} = 3 \text{ U prelim. meal bolus}$$

$$\text{Correction bolus} = (\text{prelim. correction bolus} - \text{meal IOB}) - \text{correction IOB}$$

The meal IOB is subtracted first. If the preliminary correction bolus is still above zero, then the correction IOB is subtracted.

$$\text{Meal bolus} = \text{prelim. meal bolus} - \text{remaining correction IOB}$$

Meal IOB is never subtracted from a meal bolus. Only a remaining correction IOB is subtracted from a meal bolus.

$$\text{Calculated bolus} = \text{correction bolus} + \text{meal bolus}$$

Reverse Correction bolus calculation: If the Reverse Correction feature is turned ON and if your current glucose is below your Target Glucose but above your Minimum Glucose for Calculations, the SmartBolus Calculator subtracts a correction amount from the preliminary meal bolus.

Meal bolus with Reverse Correction = Reverse Correction + prelim meal bolus

Example: Current BG or Sensor: 4.2 mmol/L (75 mg/dL), Target Glucose:

8.3 mmol/L (150 mg/dL) Correction Factor: 2.8 (50),

Preliminary meal bolus: 2.5 U

$\frac{4.2 \text{ mmol/L (75 mg/dL)} - 8.3 \text{ mmol/L (150 mg/dL)}}{2.8 (50)} = -1.5 \text{ U Reverse Correction}$

2.8 (50)

- 1.5 U (Reverse Correction) + 2.5 U (prelim. meal bolus) = 1.0 U meal bolus

A Reverse Correction is only applied to the meal bolus. In this example, the meal bolus is reduced by 1.5 units, resulting in a meal bolus of 1.0 U.

SmartBolus Calculator Rules

The SmartBolus Calculator applies the following rules to the suggested bolus doses:

Rule	Detail		
Rounding	Boluses will always be rounded <i>down</i> to the nearest 0.05 U and will never be below 0 U. IOB will always be rounded <i>up</i> to the nearest 0.05 U and will never be below 0 U.		
Factors that influence the size of your bolus	Factor	Increase	Decrease
	Carbs entered	✓	
	Sensor glucose or BG value	✓	✓
	IOB		✓
	Sensor glucose trend (if using Sensor)	✓	✓
	Target Glucose	✓	✓
	Reverse Correction setting		✓
Correction IOB	Correction IOB is subtracted from both meal and correction boluses.		
Meal IOB	Meal IOB is subtracted only from the correction boluses.		

Overview of the Bolus Calculations Screen

You can tap VIEW BOLUS CALCULATIONS from the Insulin & BG history screen or tap CALCULATIONS from the SmartBolus Calculator screen if you want to view bolus calculation details.

When a sensor glucose value and trend are used for a bolus, the SmartBolus Calculator will not only consider the value but may also adjust the bolus amount for the trend. You will see these adjustments labelled in the Bolus Calculations Screen.

The screenshot shows the 'Bolus Calculations' screen with the following details:

- Correction Bolus:** 0.05 u
- Current sensor glucose value:** Glucose = 6.7, Target Glucose = 6.1
- Calculated correction and adjusted for sensor glucose trend:** Correction Factor = 2.8, $(6.7 - 6.1) / 2.8 \approx 0.21 \text{ U}$
- Meal IOB adjustment:** Meal IOB = 0.15 U, $0.21 \text{ U} - 0.15 \text{ U} = 0.06 \text{ U}$
- Correction IOB adjustment:** Correction IOB = 0 U, $0.06 \text{ U} - 0 \text{ U} \approx 0.06 \text{ U}$
- Meal Bolus:** 2.7 u
- Carbs = 27 g, IC Ratio = 10 g/U:** $27 / 10 \approx 2.7 \text{ U}$
- Correction IOB adjustment:** Remaining correction IOB = 0 U, $2.7 \text{ U} - 0 \text{ U} \approx 2.7 \text{ U}$
- Calculated Bolus:** 2.75 u
- Total Bolus:** = 2.75 u
- Correct Above:** 6.7 mmol/L
- CLOSE** button at the bottom.

18.2 SmartBolus Calculator Examples

Example 1

Eating 50 g carbs, and 0.6 U meal IOB and 0.5 U correction IOB from previous meal and correction boluses. Sensor glucose is not available and a blood glucose reading is not entered.

Correction Bolus	-- U	
BG = N/A, Target Glucose = N/A Correction Factor = N/A		
Meal IOB adjustment		← The SmartBolus Calculator does not adjust your correction bolus by the meal IOB since there is no glucose information.
Meal IOB = 0.6 U N/A: No BG reading		
Correction IOB adjustment		← The SmartBolus Calculator also does not adjust your correction bolus by the correction IOB since there is no glucose information.
Correction IOB = 0.5 U N/A: No BG reading		
Meal Bolus	5 U	
Carbs = 50 g, IC Ratio = 10 g/U $50 / 10 = 5 \text{ U}$		← You are eating 50 g carbs. With your IC Ratio at 10, you will need a 5 U meal bolus.
Correction IOB adjustment		← Your meal bolus is not adjusted by your IOB when there is no blood glucose reading or sensor glucose value.
IOB is subtracted from a bolus only when BG is known.		
Calculated Bolus	5 U	← The calculated bolus is just the meal bolus since there is no correction bolus.
Your Adjustment Meal bolus + 2 U	2 U	← You can make manual adjustments to your bolus by tapping on the Total Bolus field at the bottom of the SmartBolus Calculator screen.
Total Bolus	= 7 U	← The Total Bolus is the sum of the calculated bolus and any adjustments you made.

Example 2

Eating 30 g carbs, no meal or correction IOB. Used sensor glucose value of 10 mmol/L, with a rising trend.

<p>Correction Bolus 1.2 U</p> <p>Sensor = 10, Target Glucose = 7.2 Correction Factor = 2.8 (50) $(10 - 7.2) / 2.8 (50) = 1 \text{ U}$</p>	<p>← Your glucose is 10 mmol/L (180 mg/dL), which is 2.8 mmol/L (50 mg/dL) over your target. Because your Correction Factor is 2.8 (50), the initial correction bolus is 1 U.</p>
<p>Meal IOB adjustment</p> <p>Meal IOB = 0 U $1 \text{ U} - 0 \text{ U} = 1 \text{ U}$</p>	<p>← The SmartBolus Calculator does not adjust your correction bolus by the meal IOB since there is no meal IOB.</p>
<p>Correction IOB adjustment</p> <p>Correction IOB = 0 U $1 \text{ U} - 0 \text{ U} = 1 \text{ U}$</p> <p>Adjusted correction bolus = 1.2 U Adjusted for Sensor: Rising</p>	<p>← The SmartBolus Calculator also does not adjust your correction bolus by the correction IOB since there is no correction IOB. The correction bolus is increased to account for your rising sensor glucose trend.</p>
<p>Meal Bolus 3.6 U</p> <p>Carbs = 30 g, IC Ratio = 10 g/U $30 / 10 = 3 \text{ U}$</p>	<p>← You are eating 30 g carbs. With your IC Ratio at 10, you will need a 3 U meal bolus. The SmartBolus Calculator does not adjust your meal bolus by the correction IOB since there is no correction IOB.</p>
<p>Correction IOB adjustment</p> <p>Remaining correction IOB = 0 U $3 \text{ U} - 0 \text{ U} = 3 \text{ U}$</p> <p>Adjusted meal bolus = 3.6 U Adjusted for Sensor: Rising</p>	<p>← The SmartBolus Calculator does not adjust your meal bolus by the correction IOB since there is no correction IOB.</p> <p>← The meal bolus is increased to account for your rising sensor glucose trend.</p>
<p>Calculated Bolus 4.8 U</p>	<p>← The calculated bolus is the sum of your correction bolus and meal bolus that has been adjusted for the rising sensor glucose value.</p>
<p>Total Bolus 4.8 U</p>	<p>← The total bolus is the sum of the calculated bolus and any adjustment you made.</p>

18 Understanding SmartBolus Calculator Calculations

Example 3

No carbs entered, used sensor glucose value of 10 mmol/L (180 mg/dL) with a decreasing trend. There is 0.8 U meal IOB and 0.5 U correction IOB from the previous meal and correction boluses.

Correction Bolus	0 U	← Your glucose is 10 mmol/L (180 mg/dL), which is 2.8 mmol/L (50 mg/dL) over target. Because your Correction Factor is 2.8 (50), the initial correction bolus is 1 U.
Sensor = 10, Target Glucose = 7.2 Correction Factor = 2.8 (50) $(10 - 7.2) / 2.8 (50) = 1 \text{ U}$		
Meal IOB adjustment		← Since you have 0.8 U of meal IOB remaining from a previous meal bolus, this is subtracted from the initial correction bolus of 1 U, and you have 0.2 U of correction bolus remaining.
Meal IOB = 0.8 U $1 \text{ U} - 0.8 \text{ U} = 0.2 \text{ U}$		
Correction IOB adjustment		← You also have 0.5 U of correction IOB from previous insulin action. This is subtracted from the remaining correction bolus of 0.2 U, driving the final calculated correction bolus to 0 U. Note that 0.3 U of correction IOB still remains after driving the correction bolus to 0 U, and this is used in the meal bolus calculations.
Correction IOB = 0.5 U $0.2 \text{ U} - 0.5 \text{ U} \leq 0 \text{ U}$		
Meal Bolus	0 U	← You did not enter any carbs, so you do not receive any calculated meal bolus dose.
Carbs = 0 g, IC Ratio = 10 g/U $0 / 10 = 0 \text{ U}$		
Correction IOB adjustment		← Although there is a remaining correction IOB of 0.3 U, your initial meal bolus is already at 0 U, so it is not adjusted further, and your meal bolus remains at 0 U.
Remaining correction IOB = 0.3 U $0 \text{ U} - 0.3 \text{ U} \leq 0 \text{ U}$		
Calculated Bolus	0 U	← Even though your glucose is above target, you have enough IOB. As a result, the SmartBolus Calculator recommends that you do not deliver any additional insulin.
Total Bolus	0 U	

USING A SENSOR WITH OMNIPOD 5

Sensor Important Safety Information

- 19 Using a Dexcom G6 Sensor with Omnipod 5
- 20 Using a FreeStyle Libre 2 Plus Sensor with Omnipod 5



This page intentionally left blank.

Sensor Important Safety Information

Sensor Warnings

Warning: ALWAYS be aware of your current sensor glucose value, trust how your body feels and do not ignore symptoms of high and low glucose. Even though insulin delivery adjusts automatically in Automated Mode, with the goal of bringing your glucose level to your defined Target Glucose, severe hypoglycaemia or hyperglycaemia may still occur.

If your sensor glucose values do not match your symptoms, ALWAYS check your blood glucose using a BG meter and consider treatment and/or Sensor calibration if necessary. ALWAYS switch to Manual Mode if you feel you are receiving inaccurate sensor glucose values.

- Erroneously high sensor glucose values can cause excessive insulin delivery, leading to severe hypoglycaemia, seizure, loss of consciousness or death.
- Erroneously low sensor glucose values can cause prolonged insulin suspension, leading to hyperglycaemia, DKA or death.

If you are having symptoms that are not consistent with your blood glucose readings and you have followed all instructions described in this *Technical User Guide*, contact your healthcare provider.

Warning: ALWAYS make sure you are using the Sensor as per the manufacturer's instructions. Do not extend the Sensor wear beyond the recommended duration and do not start a Sensor past its Use-By date. The Omnipod 5 System relies on accurate, current sensor glucose values to determine your insulin needs. Incorrect use of the Sensor could result in over-delivery or under-delivery of insulin, which can lead to hypoglycaemia or hyperglycaemia.

Warning: ALWAYS confirm that the Dexcom G6 Transmitter serial number (SN) you save in the Omnipod 5 App matches the one you are wearing. In cases where more than one person in the household uses the Dexcom G6, mis-matching Transmitter serial numbers (SN) could result in over-delivery or under-delivery of insulin, which can lead to hypoglycaemia and hyperglycaemia.

Important Safety Information

Warning: Device components including the Pod, Dexcom G6 Sensor, Dexcom G6 Transmitter, and FreeStyle Libre 2 Plus Sensor may be affected by strong radiation or magnetic fields. Device components must be removed (and the Pod and Sensor should be disposed of) before X-ray, Magnetic Resonance Imaging (MRI) or Computed Tomography (CT) scan (or any similar test or procedure). In addition, the Controller should be placed outside the procedure room. Exposure to X-ray, MRI or CT treatment can damage these components. Check with your healthcare provider on Pod removal guidelines.

Warning: DO NOT use Omnipod 5 System with the Dexcom G6 Sensor if you are taking hydroxyurea, a medication used in the treatment of diseases including cancer and sickle cell anaemia. Your Dexcom G6 sensor glucose values could be falsely elevated and could result in over-delivery of insulin, which can lead to severe hypoglycaemia.

Sensor Precautions

Caution: You cannot use the Dexcom G6 receiver with the Omnipod 5 System because the Omnipod 5 System is compatible only with the G6 App on a smartphone.

CHAPTER 19

Using a Dexcom G6 Sensor with Omnipod 5

Contents

19.1 Dexcom G6 Overview	256
19.2 Dexcom G6 Sensor Placement	257
Adult placement examples	257
Paediatric placement examples	258
19.3 Using the Dexcom G6 with Omnipod 5	258
19.4 Sensor Glucose Values	259
High and Low Sensor Glucose Values	259
Urgent Low Glucose	260
19.5 Sensor Glucose Trend Arrows	260
19.6 Communication Messages	261
19.7 About Connecting Dexcom G6 to the Pod	263
19.8 Connecting the Dexcom G6 during Initial Pod Setup	263
19.9 Connecting the Dexcom G6 Transmitter	264
19.10 Disconnecting the Transmitter from the Pod	265
19.11 Switching to Dexcom G6 from Another Sensor	265
To switch from another Sensor to Dexcom G6	265

19.1 Dexcom G6 Overview

Warning: ALWAYS be aware of your current sensor glucose value, trust how your body feels and do not ignore symptoms of high and low glucose. Even though insulin delivery adjusts automatically in Automated Mode, with the goal of bringing your glucose level to your defined Target Glucose, severe hypoglycaemia or hyperglycaemia may still occur.

If your sensor glucose values do not match your symptoms, ALWAYS check your blood glucose using a BG meter and consider treatment and/or Sensor calibration if necessary. ALWAYS switch to Manual Mode if you feel you are receiving inaccurate sensor glucose values.

- Erroneously high sensor glucose values can cause excessive insulin delivery, leading to severe hypoglycaemia, seizure, loss of consciousness or death.
- Erroneously low sensor glucose values can cause prolonged insulin suspension leading to hyperglycaemia, DKA, or death.

If you are having symptoms that are not consistent with your blood glucose readings and you have followed all instructions described in this *Technical User Guide*, contact your healthcare provider.

The Omnipod 5 System is designed to connect with the Dexcom G6 CGM System. When connected to the Dexcom G6, the Pod receives glucose values and trends from the Dexcom G6. In Automated Mode, the Pod uses sensor glucose values to make automated insulin dosing decisions every 5 minutes. In both Manual Mode and Automated Mode, a sensor glucose value and trend can be used in the SmartBolus Calculator to calculate a suggested bolus.

Read and follow all Dexcom G6 product instructions, including Safety Statements, in the *Dexcom G6 CGM System Instructions for Use*.

Note: All Sensor and Transmitter-specific actions and alerts are controlled through your Dexcom G6 App. See your *Dexcom G6 CGM System Instructions for Use* for additional information.

Note: The Dexcom G6 App and Omnipod 5 App do not directly communicate with each other. They have their own separate communication channels to acquire sensor glucose values. As a result, you may notice that, at times, the sensor glucose values may differ slightly in each App.

When connecting and using a Sensor, be aware of the following:

- Always check the Dexcom G6 expiry dates for the Sensor and Transmitter. Do not start a Sensor past its Use-By date.
- Adhere to Dexcom's approved site placements for Dexcom G6 wear.

- All Dexcom G6 alerts are configured and driven by your Dexcom G6 App. Set your Low and High alerts, as well as any other alerts in your Dexcom G6 App before using the Omnipod 5 System.

Note: The Omnipod 5 System also alerts you when your sensor glucose values are at or below 3.1 mmol/L (55 mg/dL).

- Always ensure the Transmitter serial number (SN) entered in the Dexcom G6 and Omnipod 5 Apps match the one you are wearing.

19.2 Dexcom G6 Sensor Placement

The Bluetooth connection between the Sensor and the Pod is optimal when the signal does not pass through the body. Keeping both devices at least 8 cm (3 in) apart and within the line of sight allows for consistent Transmitter communication with the Pod.

Note: Line of sight means that the Pod and Sensor are worn on the same side of the body in such a way that the two devices can “see” one another without your body blocking their communication.

Adult placement examples

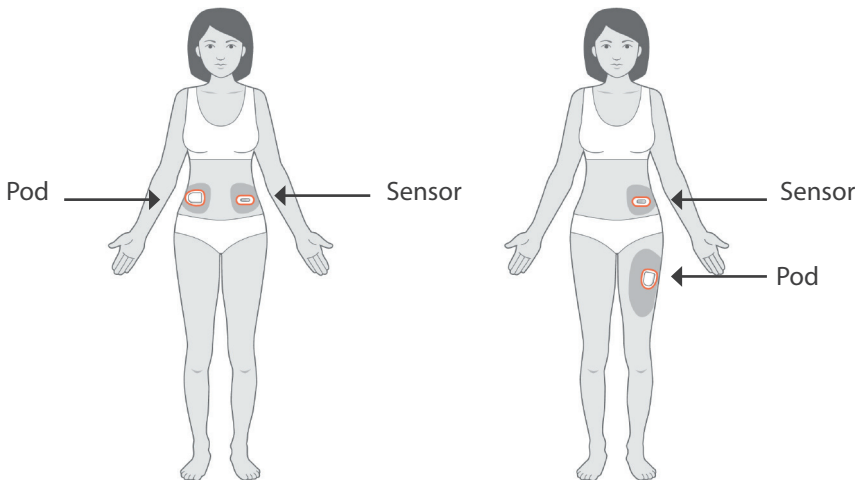

19 Using a Dexcom G6 Sensor with Omnipod 5

Paediatric placement examples

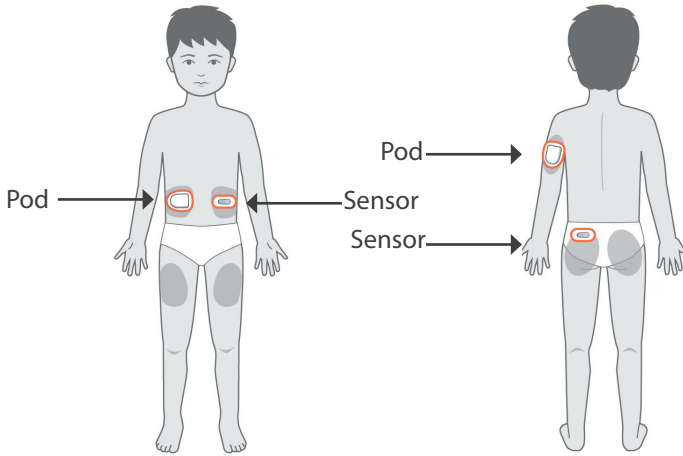

Note: Consult the *Dexcom G6 CGM System Instructions for Use* for more information on approved Sensor placement locations.

19.3 Using the Dexcom G6 with Omnipod 5

When using the Omnipod 5 System with the Dexcom G6 CGM System, you need to use the Dexcom G6 App to control your Sensor.

Caution: You cannot use the Dexcom G6 receiver with the Omnipod 5 System because the Omnipod 5 System is compatible only with the G6 App on a smartphone.

19.4 Sensor Glucose Values

Sensor glucose values are displayed on the DASHBOARD. The DASHBOARD also displays a sensor glucose trend arrow to indicate whether sensor glucose values are trending up, down or holding steady. In Automated Mode, the system takes your sensor glucose trend into account every 5 minutes when making automated insulin delivery decisions.

In Manual Mode and Automated Mode, the sensor glucose value and trend can be used in the SmartBolus Calculator. The SmartBolus Calculator can increase or decrease your bolus as needed based on your sensor glucose value and trend.

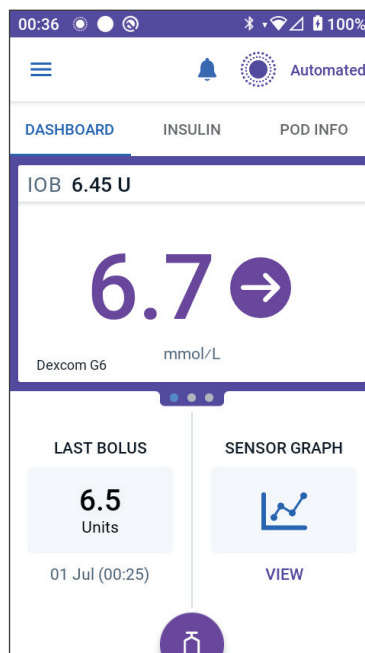

High and Low Sensor Glucose Values

The Omnipod 5 App indicates high and low sensor glucose values as follows.

Sensor Glucose Values	Screen display
Dexcom G6: Above 22.2 mmol/L (400 mg/dL) FreeStyle Libre 2 Plus: Above 27.8 mmol/L (500 mg/dL)	HIGH
Below 2.2 mmol/L (40 mg/dL)	LOW

Note: Sensor glucose values are automatically recorded on the Omnipod 5 System and do not need to be entered on the Enter BG screen.

Urgent Low Glucose

Warning: ALWAYS promptly treat low glucose. Glucose at or below 3.1 mmol/L (55 mg/dL) indicates significant hypoglycaemia (very low glucose). If left untreated, this could lead to seizure, loss of consciousness or death. Follow your healthcare provider's recommendations for treatment.

When your sensor glucose value is at or below 3.1 mmol/L (55 mg/dL), your Dexcom G6 will send the value to your Pod. The Pod will sound an Advisory Alarm to let you know that your glucose is very low. You can acknowledge the alarm from your Controller. See "13.7 Advisory Alarm List" on page 166.

Note: This Alarm will occur again if another sensor glucose value of 3.1 mmol/L (55 mg/dL) or lower is received after the initial Advisory Alarm was acknowledged.

Note: This Advisory Alarm will only stop repeating after a glucose value of 3.2 mmol/L (56 mg/dL) or greater is received. You may silence this Advisory Alarm for 30 minutes by acknowledging the on-screen message.

Note: Use a BG meter to confirm your glucose. Treat low glucose as needed.

Note: The Urgent Low Glucose Advisory Alarm has to do directly with your body's current glucose, while other alarms have to do with the Pod or Omnipod 5 App state.







19.5 Sensor Glucose Trend Arrows

Trend arrows display per Dexcom specifications. The arrow colour matches the sensor glucose value colour. For more information, refer to the *Dexcom G6 CGM System Instructions for Use*.

The colour of the sensor glucose value and trend arrow can vary as follows:

Sensor Glucose Value Colour	Description
Purple	Sensor glucose value is within Glucose Goal Range (Automated Mode)
Blue	Sensor glucose value is within Glucose Goal Range (Manual Mode)
Red	Sensor glucose value is below Glucose Goal Range
Orange	Sensor glucose value is above Glucose Goal Range

The following table describes the sensor glucose trend arrows. The trend arrows are shown in blue for example purposes only.

Trend Arrows	Description
	Steady; decreasing/increasing less than 0.1 mmol/L (1 mg/dL) per minute
 	Slowly falling/rising; glucose could decrease/increase 3.4 mmol/L (62 mg/dL) in 30 minutes
 	Falling/rising; glucose could decrease/increase 5 mmol/L (90 mg/dL) in 30 minutes
 	Rapidly falling/rising; glucose could decrease/increase more than 5 mmol/L (90 mg/dL) in 30 minutes

19.6 Communication Messages

Communication Message	Description
CONNECTING TRANSMITTER	Occurs after you have entered a Transmitter serial number (SN) and the Pod is attempting to connect with the Transmitter.
DEXCOM ISSUE DETECTED	When sensor glucose values are not available due to a Sensor error (including Sensor expiry). See the Dexcom G6 App for details. No action is required within the Omnipod 5 App.
SEARCHING FOR POD	When Pod communication was not established within the most recent 5-minute update interval. Tap MORE INFORMATION for potential causes and recommended actions.

19 Using a Dexcom G6 Sensor with Omnipod 5

Communication Message	Description
SEARCHING FOR Sensor	When the Sensor is active and connected to the Omnipod 5 Pod but the most recent sensor glucose value was not acquired within the 5-minute window. There may be no valid sensor glucose value available due to a Pod/Sensor communication issue or a temporary Sensor issue (recoverable without any user action). Tap MORE INFORMATION for recommended action. Review Pod and Sensor placement. Pod and Sensor should be at least 8 cm (3 in) apart and within the line of sight.
TRANSMITTER ERROR	When the Transmitter connected with the Omnipod 5 System has expired or experienced a non-recoverable error. Tap NEED HELP for potential causes and recommended actions. To set up a new Transmitter, see “Sensor” on page 258.
TRANSMITTER NOT FOUND	When the Pod tried to connect with a Transmitter but after 20 minutes was unable to do so. This can also happen when a Transmitter is still connected to a discarded Pod. This can also happen when a Transmitter is still connected to a discarded Pod. Tap NEED HELP for potential causes and recommended actions. See “Sensor” on page 258 for additional information.
WAITING FOR DEXCOM SET-UP	When the Transmitter is connected but sensor glucose values are unavailable because the Dexcom G6 is in Sensor warm-up or requires calibration. See the Dexcom G6 App for details. No action is required within the Omnipod 5 App.

Note: For all Sensor-related issues, refer to your *Dexcom G6 CGM System Instructions for Use*.

19.7 About Connecting Dexcom G6 to the Pod

The Omnipod 5 System is designed to work with the Dexcom G6 CGM. To use the Dexcom G6 CGM with the Omnipod 5 System, you will need to obtain the Dexcom G6 Sensor and Transmitter *and the Dexcom G6 Instructions for Use*, and download the Dexcom G6 App on your personal smartphone.

Before you can view and use sensor glucose values in the Omnipod 5 System, you must first set up the Omnipod 5 System to allow the Pod to communicate with the Sensor. Once connected, you will be able to use the system in Automated Mode, view sensor glucose values in the Omnipod 5 App, and use sensor glucose values in the bolus calculator in both Manual and Automated Modes.

Note: The Dexcom G6 Sensor must be started in the Dexcom App in order to use sensor glucose values and trends in the Omnipod 5 System.

Before you begin, do the following:

- The Omnipod 5 System will not connect with the Transmitter if you are using the Dexcom receiver. If you have an existing Transmitter that is connected to your receiver, turn off your receiver. You will need to use the Dexcom G6 App on your smartphone. For instructions about using the Dexcom G6 CGM System, see the *Dexcom G6 CGM System Instructions for Use*.

19.8 Connecting the Dexcom G6 during Initial Pod Setup

To connect the Transmitter during initial Pod setup:

1. After activating your Pod during initial setup, tap **CONNECT Sensor**.

Note: If you tap **NOT NOW** after activating your Pod during initial setup, you can connect the Sensor and Transmitter at a later time. See “Connecting the Dexcom G6 Transmitter” in the next section.

2. Go to step 3 of “Connecting the Dexcom G6 Transmitter” in the next section.

19.9 Connecting the Dexcom G6 Transmitter

Warning: ALWAYS confirm that the Dexcom G6 Transmitter serial number (SN) you save in the Omnipod 5 App matches the one you are wearing. In cases where more than one person in the household uses the Dexcom G6, mis-matching Transmitter serial numbers (SN) could result in over-delivery or under-delivery of insulin, which can lead to hypoglycaemia and hyperglycaemia.

If you had previously connected a Transmitter and your Transmitter has expired, or you have deleted the Transmitter serial number (SN) and wish to reconnect, you must enter a new SN.

To connect the Dexcom G6 Transmitter:

1. From the Home screen, tap Menu button (☰) > Manage Sensor.

The Manage Sensor screen displays the saved SN.

Note: If the Transmitter SN was previously deleted, the SN field is empty. (See “19.10 Disconnecting the Transmitter from the Pod” on page 265).

2. Tap ENTER NEW.
3. Tap the SN field to display the alphanumeric keypad.
4. Enter the SN printed on the back of your Transmitter or on the Transmitter box, then tap Done.
5. Tap SAVE.

Note: If you tap CANCEL or exit the current screen (by pressing the back arrow), the SN is not saved.

6. Tap CONFIRM to start connecting your Transmitter to your Pod. The connection process can take up to 20 minutes.

When Pod communication is successful, the screen displays “Connecting Transmitter.”

If the Pod is unable to connect with the Transmitter within 20 minutes, the message “Transmitter Not Found” displays. Tap NEED HELP for more information. See “26.3 Sensor FAQs” on page 366 for additional information.

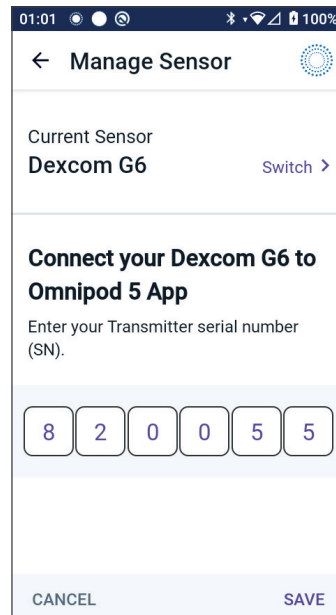

If you do not have an active Pod or you are changing your Pod, the Transmitter serial number (SN) will be saved and sent to the next Pod that is activated.

19.10 Disconnecting the Transmitter from the Pod

To stop the Pod from communicating with the Transmitter, delete the SN. If you delete the SN, you will no longer be able to enter Automated Mode until a new Transmitter SN is added.

To delete the SN:

1. From the Home screen, tap Menu button (☰) > Manage Sensor.
The Manage Sensor screen displays the saved SN.
2. Tap DELETE.
3. Tap OK, DELETE to confirm.

19.11 Switching to Dexcom G6 from Another Sensor

The Omnipod 5 System is compatible with more than one brand or model of Sensor. If you want to switch to using the Dexcom G6 Sensor with your Omnipod 5 System from another type of compatible Sensor, you can switch Sensors in the Omnipod 5 App.

Note: Switching Sensors must be done between Pod changes. A single Pod cannot connect with more than one brand or model of Sensor during its wear.

To switch from another Sensor to Dexcom G6

Follow the 8 steps below:

1. Navigate to Menu button (☰) > Manage Sensor.

Note: You cannot switch Sensors while wearing an active Pod. If you have an active Pod, Wait for next Pod change will display on the screen when you try to switch.

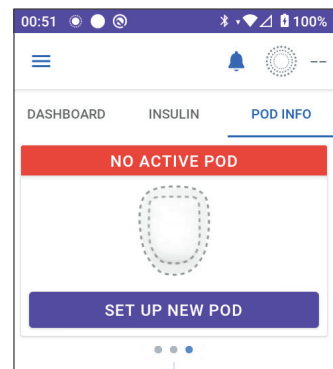

19 Using a Dexcom G6 Sensor with Omnipod 5

- The Omnipod 5 App shows your current Sensor.

Tap **Switch >** to switch to a different (or to no) Sensor.

For example, you may have been using a FreeStyle Libre 2 Plus Sensor and would now like to switch to a Dexcom G6 Sensor.

- The Sensor Selection screen shows your options with your current Sensor selected.

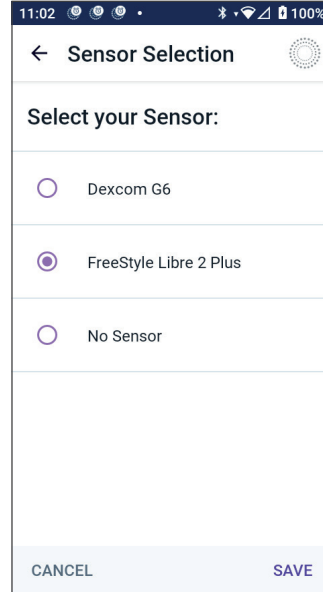

- To switch to the Dexcom G6 Sensor, select Dexcom G6.

Tap **SAVE**.

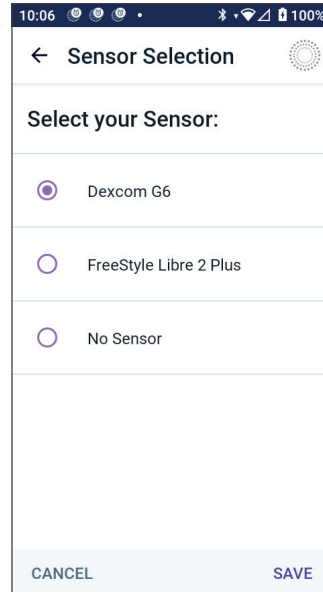

5. Confirm your switch to Dexcom G6.
Tap **CONFIRM** to acknowledge.

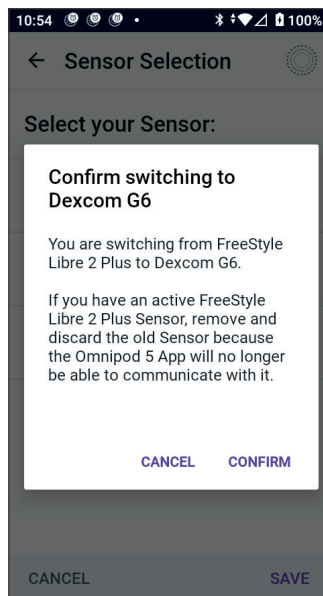

6. The Omnipod 5 App will ask:
Do you want to add the Dexcom G6 Sensor to Omnipod 5 now?
Tap **ADD** to begin the process of adding your Dexcom G6 Sensor to Omnipod 5.
Tap **NOT NOW** to add a Dexcom G6 Sensor to Omnipod 5 later.

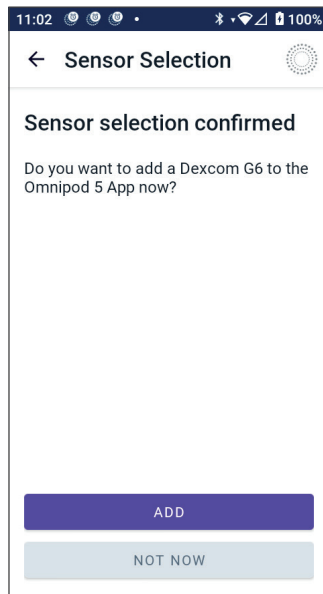

7. Add your Dexcom G6 Transmitter by entering your Transmitter serial number (SN) into the Omnipod 5 App. See "19.9 Connecting the Dexcom G6 Transmitter" on page 264.
8. Activate a new Pod.

When Pod communication is successful, the screen displays "Connecting Transmitter".

If the Pod is unable to connect with the Dexcom G6 Transmitter within 20 minutes, the message "Transmitter Not Found" displays. Tap **NEED HELP** for more information. See "26.3 Sensor FAQs" on page 366.

If you do not have an active Pod, the Transmitter serial number will be saved and sent to the next Pod you activate.

This page intentionally left blank.

CHAPTER 20

Using a FreeStyle Libre 2 Plus Sensor with Omnipod 5

Contents

20.1 FreeStyle Libre 2 Plus Sensor Overview	271
20.2 FreeStyle Libre 2 Plus Sensor Application and Placement .	273
Applying the Sensor	273
Scanning the Sensor to Activate.....	274
20.3 Using a FreeStyle Libre 2 Plus Sensor with the Omnipod 5 App	275
Using a FreeStyle Libre 2 Plus Sensor without an active Pod (Sensor-only state)	276
Adding a FreeStyle Libre 2 Plus Sensor to Omnipod 5	277
Review Sensor Glucose Values.....	278
High Glucose Alarm.....	278
Low Glucose Alarm.....	279
Missing Sensor Glucose Values Alarm	280
Urgent Low Glucose	281
20.4 Sensor Glucose Trends and Indicators	281
Glucose Trend Arrows.....	282
View Sensor Glucose Graph	282
20.5 FreeStyle Libre 2 Plus Sensor Communication and Problem Messages	283
Communication Messages	283
Problem Messages.....	285
Sensor too cold.....	286
Sensor too hot.....	286
Temporary Sensor problem.....	287
Sensor ended.....	287
No Sensor	288
Replace Sensor	288
Failed to Connect.....	289
How to respond to Problem Messages.....	289
20.6 About Connecting a FreeStyle Libre 2 Plus Sensor to the Pod	290

- 20.7 Connecting a FreeStyle Libre 2 Plus Sensor during Initial Pod Setup 291**
- 20.8 Sensor Removal: Expiry and Deletion 295**
 - Sensor Ending295
 - Deleting a Sensor296
- 20.9 Switching to FreeStyle Libre 2 Plus from Another Sensor .. 298**

20.1 FreeStyle Libre 2 Plus Sensor Overview

Warning: ALWAYS be aware of your current sensor glucose value, trust how your body feels and do not ignore symptoms of high and low glucose. Even though insulin delivery adjusts automatically in Automated Mode, with the goal of bringing your glucose level to your defined Target Glucose, severe hypoglycaemia or hyperglycaemia may still occur.

If your sensor glucose values do not match your symptoms, ALWAYS check your blood glucose using a BG meter and consider treatment and/or Sensor calibration if necessary. ALWAYS switch to Manual Mode if you feel you are receiving inaccurate sensor glucose values.

- Erroneously high sensor glucose values can cause excessive insulin delivery, leading to severe hypoglycaemia, seizure, loss of consciousness or death.
- Erroneously low sensor glucose values can cause prolonged insulin suspension, leading to hyperglycaemia, DKA or death.

If you are having symptoms that are not consistent with your blood glucose readings and you have followed all instructions described in this *Technical User Guide*, contact your healthcare provider.

The Omnipod 5 System is designed to connect with the FreeStyle Libre 2 Plus Flash Glucose Monitoring System. When connected to the FreeStyle Libre 2 Plus Sensor, the Pod receives glucose values and trends directly from the FreeStyle Libre 2 Plus Sensor. In Automated Mode, the Pod uses sensor glucose values to make automated insulin dosing decisions every 5 minutes. In both Manual Mode and Automated Mode, a sensor glucose value and trend can be used in the SmartBolus Calculator to calculate a suggested bolus.

Read and follow all FreeStyle Libre 2 Plus Sensor instructions, including Safety Statements, in the *FreeStyle Libre 2 Plus Instructions for Use*.

Note: All Sensor-specific actions and alerts are controlled through your Omnipod 5 App. The Sensor must be started by the Omnipod 5 App to pair with a Pod.

When connecting and using a FreeStyle Libre 2 Plus Sensor, be aware of the following:

- Do NOT use if the Sensor Kit package, Sensor Pack, or Sensor Applicator appear to be damaged or already opened due to the risk of no results and/or infection.
- Do NOT use if the Sensor Kit contents are past their expiry date.

20 Using a FreeStyle Libre 2 Plus Sensor with Omnipod 5

- Check that the sensor codes match on the Sensor Pack and Sensor Applicator before using. Different Sensor codes will result in incorrect sensor glucose values.
- The FreeStyle Libre 2 Plus Sensor is worn on the back of the upper arm.
- All FreeStyle Libre 2 Plus Sensor alerts are configured and driven by your Omnipod 5 App. You will set your Low and High Glucose and Missing Sensor Values alerts during first-time setup of your Sensor with your Omnipod 5 System.

The FreeStyle Libre 2 Plus Sensor continuously monitors glucose and, when used with the Omnipod 5 System, sends glucose values and trends wirelessly to your Pod. The FreeStyle Libre 2 Plus Sensor requires no fingersticks.

The FreeStyle Libre 2 Plus system includes:

- **Sensor Pack:** Contains one sterile Sensor.
- **Sensor:** Circle-shaped Sensor worn on the back of the upper arm. The Sensor has a thin, flexible filament that is painlessly inserted just under the skin.
- **Applicator:** Used to pick up the Sensor from the Sensor Pack and to apply the Sensor to your arm.
- **Controller:** Sensors are started and managed using the Omnipod 5 App running on the Insulet-provided Controller.

When used with an active Pod: Sensor glucose values and trend are sent directly to the Pod for use in automating insulin delivery. The value and trend are displayed in the Omnipod 5 App.

When used without an active Pod: If you choose to use your Omnipod 5 App without a Pod, such as if you're returning to injections for a few days, you can still use the Omnipod 5 App to manage your glucose. Without an active Pod, the Sensor will send sensor glucose values and trend directly to the App.

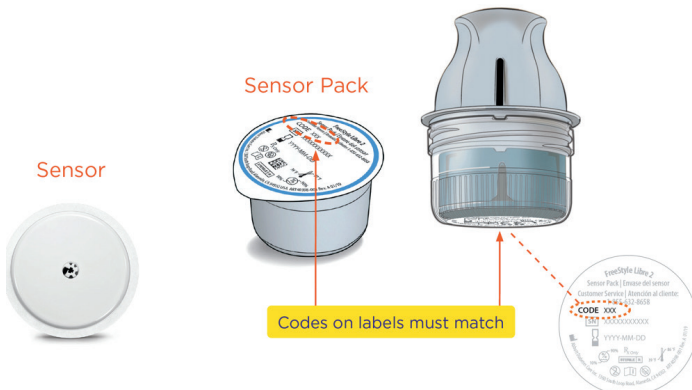

20.2 FreeStyle Libre 2 Plus Sensor Application and Placement

After you have activated a Pod, you will set up FreeStyle Libre 2 Plus as your Sensor of choice.

Applying the Sensor

To apply a Sensor:

1. Clean, Disinfect and Dry the intended site.

- a. Select a site on the back of your upper arm that stays flat during normal activity.
- b. Clean the skin with non-moisturising, fragrance-free soap and water.
- c. Use an alcohol wipe to disinfect the skin and let it air dry before proceeding.
- d. Choose a site that is within the line of sight of and at least 2.5 cm (1 in) away from your Pod.

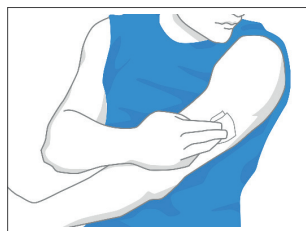

Note: Line of sight means that the Pod and Sensor are worn on the same side of the body in such a way that the two devices can “see” one another without your body blocking their communication.

Note: Note: Avoid scars, moles, stretch marks, lumps and insulin injection sites. To prevent skin irritation, rotate sites between applications.

2. Prepare the Applicator.

- Open the Sensor Pack by peeling back the lid.
- Unscrew the cap from the bottom of the Sensor Applicator.
- Line up the marks on the Sensor Applicator as you insert it into the Sensor Pack.
- Press down firmly on the Applicator on a hard surface until it comes to a stop. Then lift the Applicator.

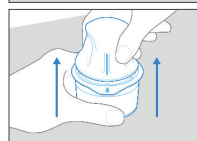
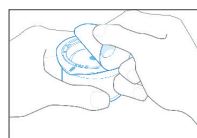

The Sensor Applicator is now ready to apply the Sensor.

Caution: The Sensor Applicator contains a needle. Do not touch the inside of the Sensor Applicator or put it back into the Sensor Pack.

3. Apply the Sensor.

- Place the Sensor Applicator over the selected site on the back of your upper arm and press firmly to apply.
- Gently pull the Sensor Applicator away from your body.
- Make sure the Sensor is secure by pressing down on the Sensor and running your finger along the Sensor adhesive.

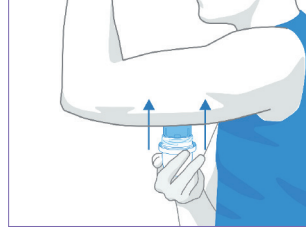

Caution: Do not push down on Sensor Applicator until placed over prepared site to prevent unintended results or injury.

Scanning the Sensor to Activate

To activate the Sensor:

1. To add the FreeStyle Libre 2 Plus Sensor to the Omnipod 5 App, tap **ADD SENSOR**.

If you are not in Manual Mode, you will be prompted to switch to Manual Mode.

Note: If you have not already applied your Sensor to your body, you will be prompted to do so before continuing.

2. Scan the FreeStyle Libre 2 Plus Sensor by holding the bottom third of your Controller up to the Sensor.

Hold the Controller near the Sensor, and do not move it until the Controller vibrates to show that the scan is complete.

Note: It can scan through your clothes.

3. When you bring the Controller up to the Sensor, it will activate the scan.

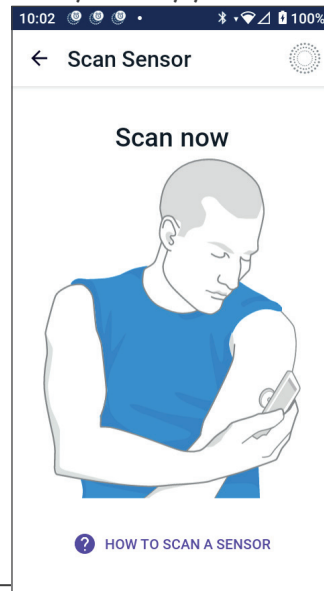

When the scan successfully completes, a message shows that you will not need to scan again until you start a new Sensor.

Tap OK.

Note: The Pod receives an updated sensor glucose value and trend every 5 minutes. You will not need to scan the Sensor for a new value. If you do not have an active Pod, the Omnipod 5 App will update its displayed glucose value from the Sensor.

4. The Sensor will begin its 1-hour warm-up.

You can watch the progress of the warm-up on the Omnipod 5 App Home screen.

At the end of the warm-up period, your sensor glucose values are available to view in the App and for use in Automated Mode to adjust your insulin delivery.

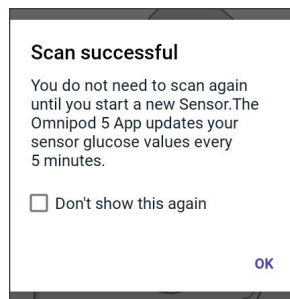

20.3 Using a FreeStyle Libre 2 Plus Sensor with the Omnipod 5 App

After you have connected the FreeStyle Libre 2 Plus Sensor to the Omnipod 5 System, the Pod will receive a sensor glucose value from the Sensor every 5 minutes. These values are sent from the Pod to the Omnipod 5 App, allowing you to monitor your glucose and insulin delivery. If you use the Sensor without an active Pod, the App receives glucose values directly from the Sensor.

Using a FreeStyle Libre 2 Plus Sensor without an active Pod (Sensor-only state)

There may be times when you want to continue using a Sensor but take a break from using a Pod in favour of another insulin therapy, like injections. Since you typically use the Omnipod 5 App to start your Sensor and view your sensor glucose information, you can continue to do this even without an active Pod.

For the Sensor-only state (no active Pod), the Omnipod 5 App will update sensor glucose values every 5 minutes directly from the FreeStyle Libre 2 Plus Sensor, rather than from a Pod. You will be able to view your Sensor graph, as well as alerts about high or low glucose. You will not receive information on insulin status until you activate a new Pod.

Note: You can use the Omnipod 5 App in the Sensor-only state for up to 30 days. If you plan to use an alternative insulin therapy, like injections, for more than 30 days, ask your healthcare provider about moving to a standalone FreeStyle Libre 2 Plus system. Remember that, to use a Sensor with the Omnipod 5 App, it must be scanned and started by the Omnipod 5 App.

Note: In the Sensor-only state, the Omnipod 5 Controller must be nearby and within the line of sight of the Sensor for sensor glucose values to appear on the screen. Bring the Controller closer to the Sensor if you don't see values displayed.

Adding a FreeStyle Libre 2 Plus Sensor to Omnipod 5

To add a Sensor to the Omnipod 5 App, follow the 5 steps below:

1. Home screen shows no Sensor is detected.

Note: Before applying and scanning the FreeStyle Libre 2 Plus Sensor, the Omnipod 5 App will ask you to review and adjust (if necessary) your Sensor settings.

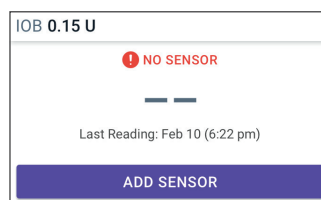

2. After you have reviewed and adjusted (if necessary) your Sensor settings,

Tap ADD SENSOR.

3. Apply a FreeStyle Libre 2 Plus Sensor. After you have applied the Sensor, tap CONTINUE.

4. Next, you will scan the FreeStyle Libre 2 Plus Sensor by placing the Controller up to the FreeStyle Libre 2 Plus Sensor, allowing it to scan the Sensor and begin activation. Do not move the Controller until the scan is complete.

Tap OK.

5. After you have selected FreeStyle Libre 2 Plus as your Sensor option and you have reviewed your Sensor settings, confirm that you want to add your Sensor to the Omnipod 5 App.

Tap ADD to proceed.

Or tap NOT NOW to add the FreeStyle Libre 2 Plus Sensor to the Omnipod 5 App later.

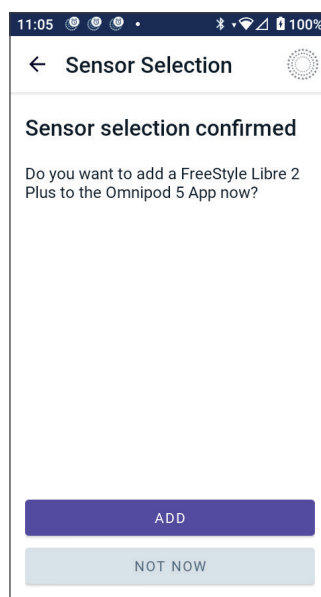

Review Sensor Glucose Values

The Omnipod 5 App is where you can review and adjust your settings for high and low sensor glucose value alarms.

There are 3 optional, adjustable Sensor alarms to alert you to out-of-range glucose.

High Glucose Alarm

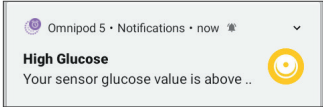
Screen Displayed:	 <p>The screenshot shows a notification from the Omnipod 5 app. At the top, it says 'Omnipod 5 • Notifications • now'. Below that, the title is 'High Glucose' and the message reads 'Your sensor glucose value is above ..'. To the right of the text is a yellow smiley face icon.</p>
Cause:	The notification is set to ON and your sensor glucose value is above your High Glucose setting.
Controller sound and vibration:	<ul style="list-style-type: none"> • 3-second tone • 3-second vibration • Alarm repeats every 5 minutes until your sensor glucose value is below your High Glucose setting or you acknowledge the notification.
What to do:	<ol style="list-style-type: none"> 1. Acknowledge the alarm by viewing the notification in the Notification bell or by dismissing the notification from the lock screen. 2. Check your blood glucose with a BG meter to confirm your glucose value.

Low Glucose Alarm

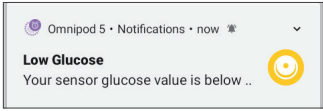
<p>Screen Displayed:</p>	
<p>Cause:</p>	<p>The notification is set to ON and your sensor glucose value is below your Low Glucose setting.</p>
<p>Controller sound and vibration:</p>	<ul style="list-style-type: none"> • 3-second tone • 3-second vibration • Alarm repeats every 5 minutes until your sensor glucose value is above your Low Glucose setting or you acknowledge the notification.
<p>What to do:</p>	<ol style="list-style-type: none"> 1. Acknowledge the alarm by viewing the notification in the Notification bell or by dismissing the notification from the lock screen. 2. Check your blood glucose with a BG meter to confirm your glucose value.

Missing Sensor Glucose Values Alarm

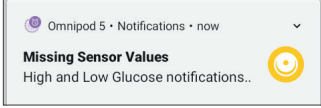
<p>Screen Displayed:</p>	
<p>Cause:</p>	<p>The notification is set to ON and sensor glucose values have not been received for 20 minutes.</p> <p>It may indicate that there has been a signal loss or a problem with your Sensor, and the Omnipod 5 App is not able to display your sensor glucose values or notify you when your sensor glucose is high or low.</p>
<p>Controller sound and vibration:</p>	<ul style="list-style-type: none"> • 3-second tone • 3-second vibration • Alarm repeats every 5 minutes for a total of 5 repeats until sensor glucose values are restored or you acknowledge the notification.
<p>What to do:</p>	<ol style="list-style-type: none"> 1. Acknowledge the alarm by viewing the notification in the Notification bell or by dismissing the notification from the lock screen. 2. Check that your Sensor is still applied to your skin. 3. To minimise the risk of interruption, make sure your FreeStyle Libre 2 Plus Sensor and Pod are worn on the same side of the body. Wireless communications do not travel well through the body. If you experience frequent connectivity loss between the Pod and Sensor, see “26.3 Sensor FAQs” on page 366.

Urgent Low Glucose

Caution: ALWAYS promptly treat low glucose. Glucose at or below 3.1 mmol/L (55 mg/dL) indicates significant hypoglycaemia (very low glucose). If left untreated, this could lead to seizure, loss of consciousness and death. Follow your healthcare provider's recommendations for treatment.

When your sensor glucose value is at or below 3.1 mmol/L (55 mg/dL), your FreeStyle Libre 2 Plus will send the value to your Pod. The Pod will sound an Advisory Alarm to let you know that your glucose is very low. You can acknowledge the alarm from your Controller.

If you do not have an active Pod, the Omnipod 5 App will issue the Advisory Alarm. See “20.5 FreeStyle Libre 2 Plus Sensor Communication and Problem Messages” on page 283.

Note: This Alarm will occur again if another sensor glucose value of 3.1 mmol/L (55 mg/dL) or lower is received after the initial Advisory Alarm was acknowledged. You may silence (snooze) this Advisory Alarm for 30 minutes by acknowledging the on-screen message.

Note: This Advisory Alarm will stop repeating only after a glucose value of 3.2 mmol/L (56 mg/dL) or greater is received.

Action to Take: Use a BG meter to confirm your glucose. Treat low glucose as needed.





20.4 Sensor Glucose Trends and Indicators

Colours and trend arrows display on the Home Screen to show your sensor glucose value and trend. They will change depending on your Glucose Goal Range.

6.7 →	Trending steady	■	— sensor glucose value is within your Goal Range (in Manual Mode)
6.7 →	Trending steady	■	— sensor glucose value is within your Goal Range (in Automated Mode)
3.8 →	Trending steady	■	— sensor glucose value is below Goal Range
14.3 ↗	Slowly rising	■	— sensor glucose value is above Goal Range.

Glucose Trend Arrows

The following table describes the sensor glucose trend arrows. The trend arrows are shown in blue for example purposes only.

Trend Arrows	Description
	Glucose is rising quickly (more than 0.1 mmol/L [2 mg/dL]) per minute)
	Glucose is rising (between 0.06 and 0.1 mmol/L [1 and 2 mg/dL] per minute)
	Glucose is changing slowly (less than 0.06 mmol/L [1 mg/dL] per minute)
	Glucose is falling (between 0.06 and 0.1 mmol/L [1 and 2 mg/dL] per minute)
	Glucose is falling quickly (more than 0.1 mmol/L [2 mg/dL] per minute)

View Sensor Glucose Graph

You can view the Sensor Graph from the Home Screen by tapping VIEW under the Sensor Graph icon in the lower right side of the Home screen.

When you tap VIEW, the Sensor Graph will display.

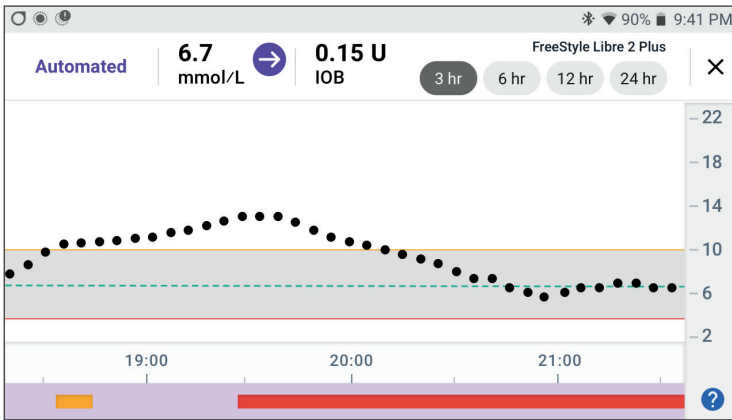

To display the Sensor Graph legend, tap the question mark icon in the lower right of the graph.

The Sensor Graph Legend will show:

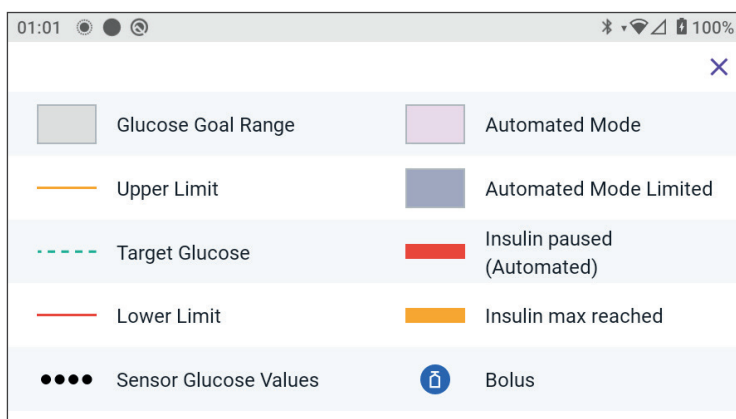

The Sensor Graph Legend explains the colours and use of lines on the graph, which show your sensor glucose and insulin delivery over the past few hours.





20.5 FreeStyle Libre 2 Plus Sensor Communication and Problem Messages

Communication Messages

The following are the communication messages that show on the Dashboard of the Omnipod 5 App that are associated with the FreeStyle Libre 2 Plus System.





Communication Message	Description
<p>CONNECTING</p> 	<p>Appears after you have applied and scanned a FreeStyle Libre 2 Plus Sensor and your device or Pod are connecting to the Sensor.</p>



20 Using a FreeStyle Libre 2 Plus Sensor with Omnipod 5

Communication Message	Description
<p>SENSOR READY AT <time></p> 	<p>Appears when the Sensor is connected and starting up and sensor glucose values are unavailable.</p> <p>No action is required within the Omnipod 5 App.</p>
<p>SENSOR CONNECTED AND READY</p> 	<p>Sensor has recently completed start-up and glucose values will be available in a few minutes.</p>
<p>SEARCHING FOR POD</p> 	<p>Appears when Pod communication was not established within the most recent 5-minute update interval.</p> <p>Tap MORE INFORMATION for potential causes and recommended actions.</p>
<p>SEARCHING FOR SENSOR</p> 	<p>Appears when a Sensor is being used with or without a Pod and the most recent sensor glucose value was not acquired within a 5-minute window.</p> <p>There may be no valid sensor glucose value available due to a communication issue between Pod and Sensor, or it could be a temporary Sensor issue (recoverable without any user action).</p> <p>Tap MORE INFORMATION for recommended action. Review Pod and Sensor placement.</p> <p>Pod and Sensor should be at least 2.5 cm (1 in) apart and within the line of sight.</p>

Problem Messages

The following is a summary of the Sensor problem messages associated with the FreeStyle Libre 2 Plus Sensor that display on the Home screen Dashboard and indicate a problem and a need for action. These messages show with a red alarm icon and are in red text. More specific information for each message follows the summary.

Dashboard Message and Display	Description of Problem	Action to Take
Sensor too cold  SENSOR TOO COLD	Your Sensor is too cold to provide a glucose value.	Move to a warmer location and try again in a few minutes.
Sensor too hot  SENSOR TOO HOT	Your Sensor is too hot to provide a glucose value.	Move to a cooler location and try again in a few minutes.
Temporary Sensor problem  TEMPORARY SENSOR PROBLEM	Your Sensor is temporarily unable to send sensor glucose values to the Pod or Omnipod 5 App.	Check again in 10 minutes.
Sensor Ended  SENSOR ENDED	Your Sensor has ended. Your Omnipod 5 Pod and App will receive no further information from this Sensor.	To use the Omnipod 5 System in Automated Mode, add a new Sensor and have an active Pod on.
No Sensor	No Sensor is detected.	To use the Omnipod 5 System in Automated Mode, add a Sensor and have an active Pod on.

Dashboard Message and Display	Description of Problem	Action to Take
Replace Sensor 	The System has detected a problem with your Sensor that cannot be fixed. Your Omnipod 5 Pod and App will receive no further information from this Sensor.	Remove old Sensor. Add a new Sensor.
Failed to Connect 	Your Pod and Sensor were not able to connect.	Try connecting again. If the problem continues, reboot your Controller or replace the recently applied Pod or Sensor.

Sensor too cold

Screen Alert	Description
Home Screen: 	<p>Why it occurs: Your Sensor is too cold to provide a glucose value.</p> <p>Pod sound: None</p> <p>Controller sound and vibration: None</p> <p>What to do:</p> <ol style="list-style-type: none"> 1. Move to a warmer location. 2. Try again in a few moments.

Sensor too hot

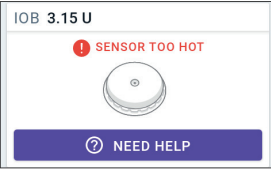
Screen Alert	Description
Home Screen: 	<p>Why it occurs: Your Sensor is too hot to provide a glucose value.</p> <p>Pod sound: None</p> <p>Controller sound and vibration: None</p> <p>What to do:</p> <ol style="list-style-type: none"> 1. Move to a cooler location. 2. Try again in a few moments.

Temporary Sensor problem

Screen Alert	Description
<p>Home Screen:</p> 	<p>Why it occurs: Your Sensor is temporarily unable to send sensor glucose values to the Pod or Omnipod 5 App.</p> <p>Pod sound: None</p> <p>Controller sound and vibration: None</p> <p>What to do:</p> <ul style="list-style-type: none"> ➤ Wait and try again in 10 minutes.

Sensor ended

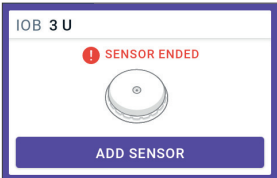
Screen Alert	Description
<p>Omnipod 5 App:</p> 	<p>Why it occurs: Your Sensor has ended. Your Omnipod 5 Pod and App will receive no further information from this Sensor.</p> <p>Pod sound: None</p> <p>Controller sound and vibration: None</p> <p>What to do: To use the Omnipod 5 System in Automated Mode, you need to add a new Sensor and have an active Pod on.</p> <ol style="list-style-type: none"> 1. Tap OK. 2. Remove the old Sensor from your body. 3. Add a new Sensor. 4. Scan the new Sensor to activate it. <p>Note: For detailed instructions, see “Applying the Sensor” on page 273 and “Scanning the Sensor to Activate” on page 274.</p>

No Sensor

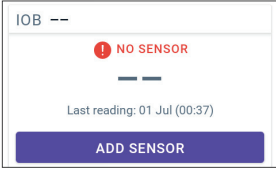
Screen Alert	Description
<p>Home Screen:</p> 	<p>Why it occurs: No Sensor is detected.</p> <p>Pod sound: None</p> <p>Controller sound and vibration: None</p> <p>What to do: To use the Omnipod 5 System in Automated Mode, add a Sensor and have an active Pod on.</p> <ol style="list-style-type: none"> 1. Tap Add Sensor. 2. Add the Sensor to your body. 3. Scan the new Sensor to activate it. <p>Note: For detailed instructions, see “Applying the Sensor” on page 273 and “Scanning the Sensor to Activate” on page 274.</p>

Replace Sensor

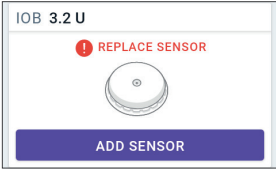
Screen Alert	Description
<p>Omnipod 5 App:</p> 	<p>Why it occurs: The System has detected a problem with your Sensor that cannot be fixed. Your Omnipod 5 Pod and App will receive no further information from this Sensor.</p> <p>Pod sound: None</p> <p>Controller sound and vibration: None</p> <p>What to do:</p> <ol style="list-style-type: none"> 1. Tap OK (from the Omnipod 5 App screen) or tap Add Sensor (from the Home screen). 2. Remove the old Sensor from your body. 3. Add a new Sensor. 4. Scan the new Sensor to activate it. <p>Note: For detailed instructions, see “Applying the Sensor” on page 273 and “Scanning the Sensor to Activate” on page 274.</p>

Failed to Connect

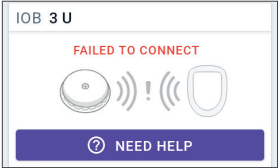
Screen Alert	Description
<p>Home Screen:</p> 	<p>Why it occurs: Your Sensor did not connect to the Pod.</p> <p>Pod sound: None</p> <p>Controller sound and vibration: None</p> <p>What to do:</p> <ol style="list-style-type: none"> 1. Try connecting the Sensor again. 2. If the problem continues, replace your Sensor.

How to respond to Problem Messages

The Omnipod 5 App displays messages on your Dashboard screen when there may be a problem with your Sensor. Respond to these issues as soon as possible.

1. When a message displays, follow the screen instructions.

For example, for the SENSOR TOO COLD alarm, tap the NEED HELP button.

2. When you tap the NEED HELP button, an explanation of the issue will show, with a recommendation of what to do next, e.g. Check in a few minutes.

If a problem continues and you receive multiple messages on your device, contact Customer Care.

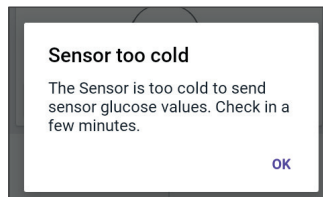
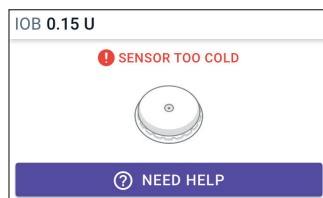

20.6 About Connecting a FreeStyle Libre 2 Plus Sensor to the Pod

The Omnipod 5 System is designed to work with the FreeStyle Libre 2 Plus Sensor. To use the FreeStyle Libre 2 Plus Sensor with the Omnipod 5 System, you will need to obtain a FreeStyle Libre 2 Plus Sensor and the FreeStyle Libre 2 Plus Instructions for Use.

Before you can view and use sensor glucose values in the Omnipod 5 System, you must first set up the Omnipod 5 System to allow the Pod to communicate with a FreeStyle Libre 2 Plus Sensor. After you are connected, you will be able to use the System in Automated Mode, view sensor glucose values in the Omnipod 5 App, and use sensor glucose values in the bolus calculator in both Manual and Automated Modes.

The Sensor can connect to the Pod during Sensor warm-up, but needs to complete warm-up before it is able to send glucose values to the Pod.

Before you begin, consider the following:

- The Omnipod 5 System will not connect with a FreeStyle Libre 2 Plus Sensor if you started the Sensor using another device. You must start the Sensor with the Omnipod 5 App.
- If you have an existing Sensor that was previously activated outside the Omnipod 5 App, the System will let you know that a new Sensor is required. Remove your current Sensor and apply a new Sensor or wait until you are ready to start a new FreeStyle Libre 2 Plus Sensor.

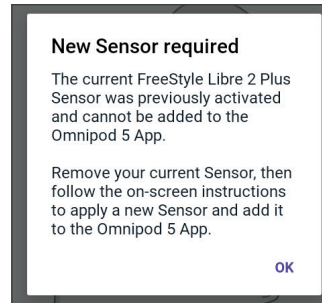

For additional instructions about using the FreeStyle Libre 2 Plus Sensor, see the *FreeStyle Libre 2 Plus Instructions for Use*.

20.7 Connecting a FreeStyle Libre 2 Plus Sensor during Initial Pod Setup

To make FreeStyle Libre 2 Plus your glucose Sensor of choice, follow these steps:

1. When prompted, select the FreeStyle Libre 2 Plus Sensor from the options on the screen.
 - Dexcom G6
 - FreeStyle Libre 2 Plus
 - No Sensor

Tap **CONFIRM**.

The App will confirm your CGM selection. Next, the App will ask you to review your CGM settings.

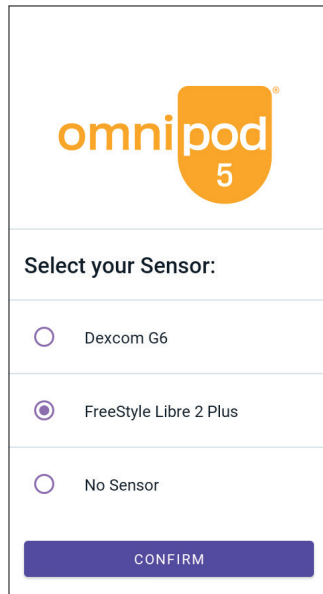

2. On the Review your Sensor settings screen, tap **OK** to review or adjust, if necessary, your FreeStyle Libre 2 Plus Sensor settings.

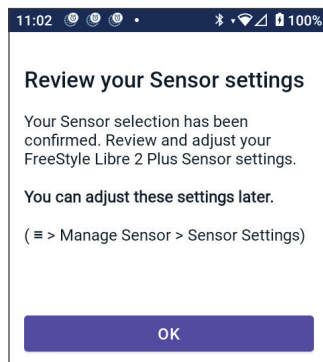

20 Using a FreeStyle Libre 2 Plus Sensor with Omnipod 5

3. Low Glucose settings: Review or adjust your Low Glucose setting.
 - The notifications are ON by default. If the toggle is OFF (greyed out), tap the toggle to turn ON.
 - If the Low Glucose setting is correct, tap NEXT to move to the High Glucose setting screen.
 - To change the Low Glucose setting, tap the glucose field to access a scroll wheel.
4. Select a Low Glucose value, then tap DONE to save your selection.
Tap NEXT to move on to the High Glucose settings screen.
5. Select your alert volume preferences.

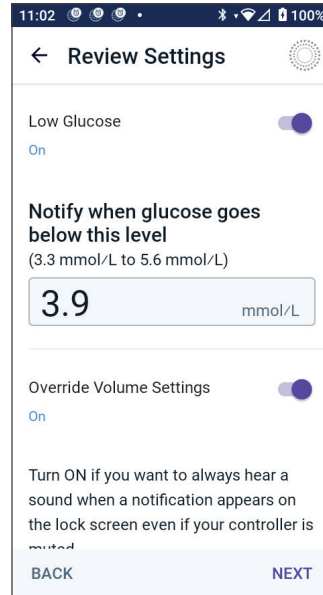

6. High Glucose settings: Review or adjust your High Glucose setting.
 - The notifications are ON by default. If the toggle is OFF (greyed out), tap the toggle to ON.
 - If the High Glucose setting is correct, tap NEXT to move to the Missing Sensor Glucose Values setting screen.
 - To change the High Glucose setting, tap the glucose field to access a scroll wheel.
7. Select a High Glucose value from the list, then tap DONE to save the value.
8. Select your alert volume preferences.
9. Tap NEXT to move on to the Missing Sensor Glucose Values screen.

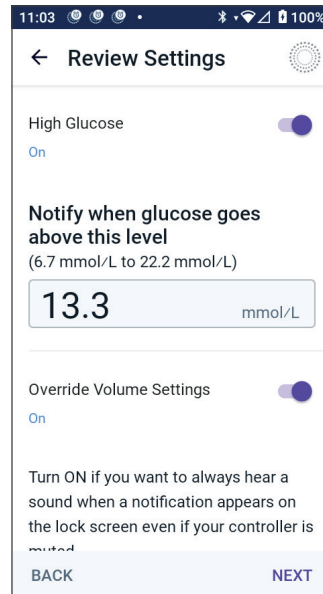

10. Missing Sensor Glucose Values: Turn on or adjust your Missing Sensor Glucose Values notification setting.

Note: The Missing Sensor Glucose Values alert is designed to notify you that sensor glucose values have not been received for 20 minutes. It may mean that there has been a signal loss between your Sensor and Pod or a problem with your Sensor.

- The notification is ON by default. If the toggle is OFF (greyed out), tap the toggle to turn ON.
- Select your alert volume preferences.
- Tap NEXT to save your Sensor settings.

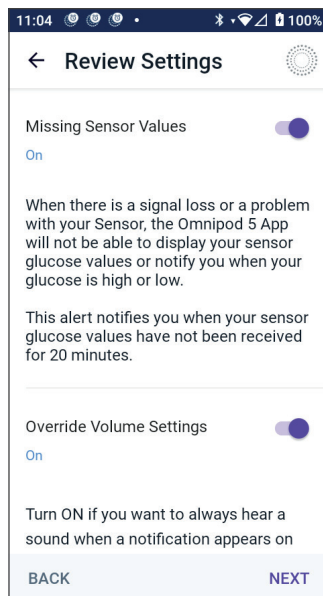

11. The System confirms that it saved your Sensor settings.

12. Next, to add your Sensor, tap ADD.

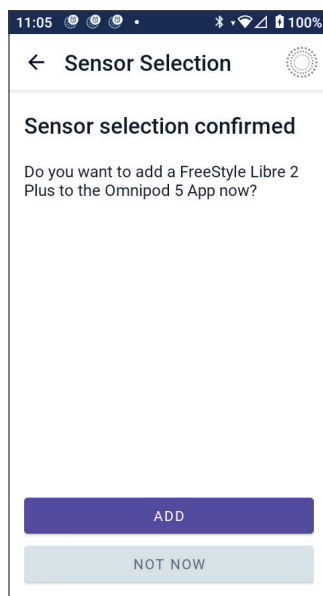

13. At this point, you can apply a FreeStyle Libre 2 Plus Sensor.

If you need more help, tap **How to Apply a Sensor** at the bottom of the screen to review step-by-step help with illustrations.

When you have applied your Sensor, tap **CONTINUE**.



14. Scan your FreeStyle Libre 2 Plus Sensor by placing the Controller up to the Sensor, allowing it to scan the Sensor, and begin activation.

If you need more help, tap **HOW TO SCAN A SENSOR** at the bottom of the screen for instructions on scanning.

After scanning, the **Scan successful** message displays:

Tap **OK**.

It can take up to 20 minutes for your Sensor to connect to your Pod and display in the App.

When Pod communication is successful: The screen will either show the number of days until your Sensor ends, or if the Sensor is still starting up, it will give the **Time Remaining** until your Sensor will be ready.

If the Pod is unable to connect with the Sensor within 20 minutes:

The message “Pod and Sensor failed to connect” displays. Try connecting again. If the problem continues, you may need to replace the Sensor.

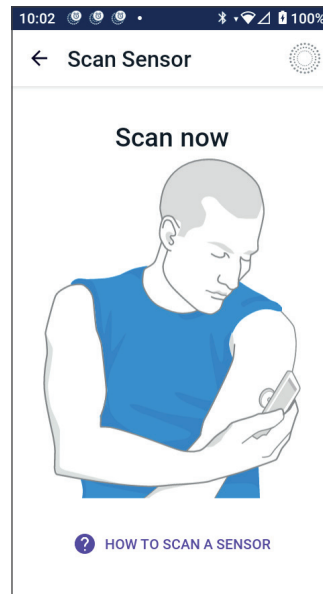

15. If Pod communication is successful, you can switch to Automated Mode.

To switch to Automated Mode, tap YES.

16. Automated: Limited state

During Sensor warm-up, and until your Sensor can send a current glucose value to the Pod, your System will be in Automated: Limited state.

When warm-up is complete and sensor glucose values are available, you will enter Automated Mode.

Your sensor glucose values are updated every 5 minutes until the System ends or is deleted from the System

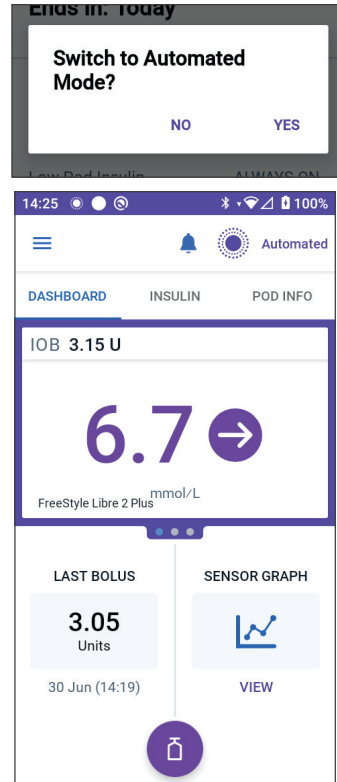

20.8 Sensor Removal: Expiry and Deletion

To take off the old Sensor, pull up the adhesive's edge and slowly peel it away in one motion.

The Sensor is disposable and should be disposed of according to local guidelines. For instructions about removing and disposing of Sensors, see the *FreeStyle Libre 2 Plus User's Manual*.

Sensor Ending

When your Sensor reaches the end of its wear duration, the Home Screen will show that your Sensor has ended with a **SENSOR ENDED** message. You can remove the Sensor from your body and apply a new Sensor. For more information about the Sensor Ended message, see "20.5 FreeStyle Libre 2 Plus Sensor Communication and Problem Messages" on page 283.

Deleting a Sensor

When you want to remove your Sensor before the end of its wear duration, you will need to delete the Sensor from Omnipod 5. Deleting a Sensor tells the Pod to stop communicating with and looking for that Sensor.

You do not need to delete a Sensor that lasts the full wear duration.

To delete a FreeStyle Libre 2 Plus Sensor through the Omnipod 5 App:

1. Tap Manage Sensor from the menu.

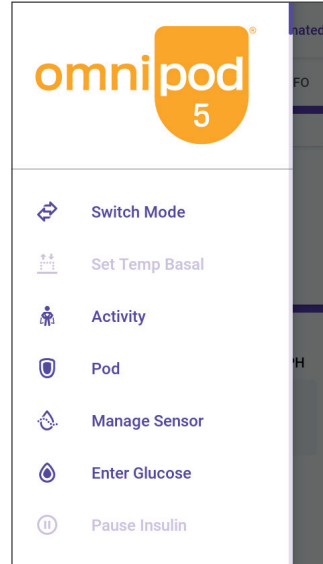

2. To delete the current Sensor, tap **DELETE SENSOR** at the bottom of the screen, so that the Pod has instructions to disconnect from the Sensor.

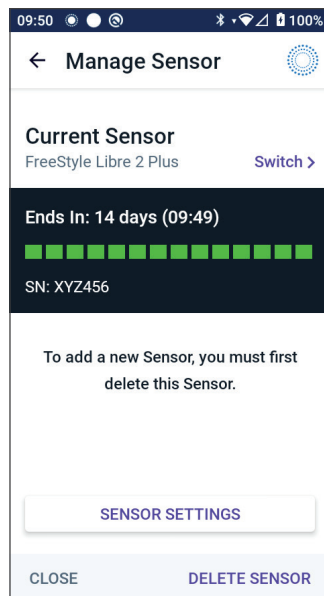

If you are in Automated Mode, “Switch to Manual Mode” will display.

Note: To delete a Sensor, you must be in Manual Mode.

3. Next, the Omnipod 5 App asks you to confirm that you want to delete the Sensor. Tap **DELETE**.

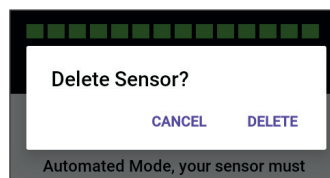

If you do not want to delete the Sensor, tap **CANCEL**.

The Omnipod 5 App confirms that the Sensor has been deleted.

4. Remove the old Sensor from your body.

When you have deleted the Sensor, the Omnipod 5 App shows that your Pod is not connected to an active Sensor.

Note: To add a new Sensor, tap **ADD SENSOR** and follow the instructions on the screen that will prompt you to apply, activate, and pair the Omnipod 5 System with the new Sensor.

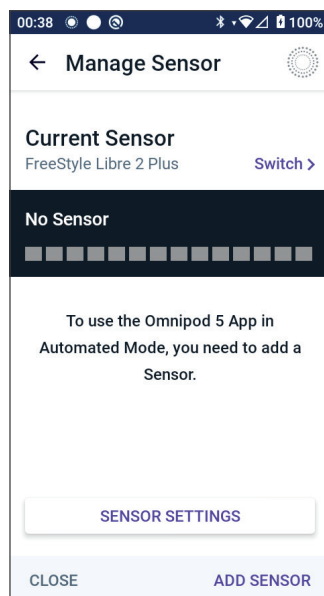

20.9 Switching to FreeStyle Libre 2 Plus from Another Sensor

The Omnipod 5 System is compatible with more than one brand or model of Sensor. If you want to switch to using a FreeStyle Libre 2 Plus Sensor with your Omnipod 5 System from another type of compatible Sensor, you can switch Sensors in the Omnipod 5 App.

Note: Switching Sensor types must be done between Pod changes. A single Pod cannot connect with more than one brand or model of Sensor during its wear period.

To switch to the FreeStyle Libre 2 Plus Sensor from another Sensor:

1. Open the Omnipod 5 App to the POD INFO screen.

Note: You cannot switch Sensor types while wearing an active Pod. If you have an active Pod, “Wait for next Pod change” will display on the screen when you try to switch.

Navigate to Menu button (☰) > Manage Sensor.

2. The Omnipod 5 App shows your current Sensor.

Tap Switch > to switch to a different (or to no) Sensor.

For example, you may have been using a Dexcom G6 and would like to switch to using a FreeStyle Libre 2 Plus Sensor.

3. The Sensor Selection screen shows your options with your current Sensor model selected.

4. To switch to the FreeStyle Libre 2 Plus Sensor with the Omnipod 5 system, select FreeStyle Libre 2 Plus.

Tap SAVE.

5. The Omnipod 5 App confirms your switch to FreeStyle Libre 2 Plus.

Tap CONFIRM to acknowledge.

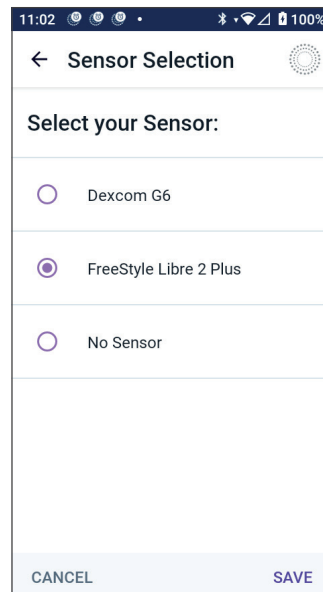
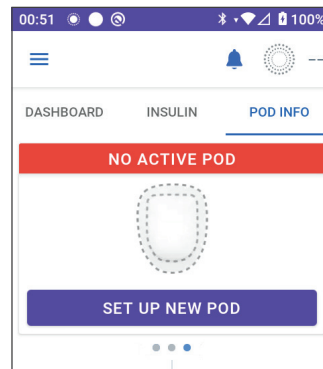

6. Review your Sensor settings

Tap OK.

A series of screens will display, allowing you to enter or adjust your notification settings for:

- Low Glucose
- High Glucose
- Missing CGM Values

Note: For detailed instructions and screen images for reviewing your settings, see Step 3 to Step 8 in “20.7 Connecting a FreeStyle Libre 2 Plus Sensor during Initial Pod Setup” on page 291.

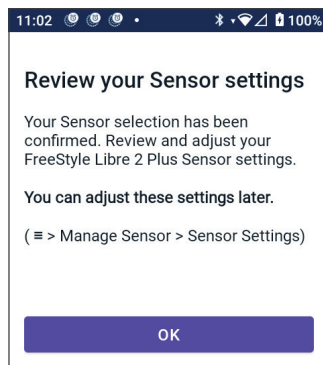

7. The Omnipod 5 App will ask:

Do you want to add a FreeStyle Libre 2 Plus Sensor to Omnipod 5 now?

Tap ADD to add your FreeStyle Libre 2 Plus Sensor.

Tap NOT NOW to add the FreeStyle Libre 2 Plus Sensor to the Omnipod 5 App later.

Follow the on-screen prompts to apply, activate and pair the Omnipod 5 System with a new Sensor.

Note: Review Section “20.7 Connecting a FreeStyle Libre 2 Plus Sensor during Initial Pod Setup” on page 291 for more information on applying and scanning a Sensor.

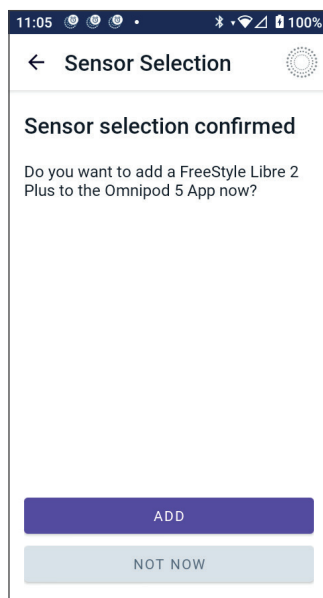

8. Next, the screens will take you through the following tasks:

- a. Apply the FreeStyle Libre 2 Plus Sensor. See step 10 on page 293 for more details.
- b. Scan and activate the new Sensor. See step 11 on page 294 for more details.
- c. Activate a new Pod and wait for the Sensor warm-up to complete. You will then be able to enter Automated Mode. See steps 12 and 13 on page 294.

9. Automated: Limited state

During Sensor warm-up, and until your Sensor can send a current glucose value to the Pod, your System will be in Automated: Limited state.

When warm-up is complete and sensor glucose values are available, you will enter Automated Mode.

Your sensor glucose values are updated every 5 minutes until the Sensor ends or is deleted from the System.

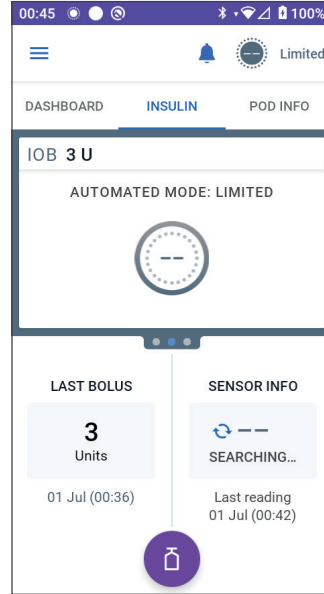

AUTOMATED MODE

- 21 About Automated Mode
.....
- 22 Switching Between Manual Mode
and Automated Mode
.....
- 23 Activity Feature
.....
- 24 Automated Mode Alarms
.....
- 25 Omnipod 5 System Clinical Studies



This page intentionally left blank.

Automated Mode Important Safety Information

Automated Mode Warnings

Warning: SmartAdjust technology should NOT be used by anyone under the age of 2 years old. SmartAdjust technology should also NOT be used in people who require less than 5 units of insulin per day as the safety of the technology has not been evaluated in this population.

Warning: DO NOT use SmartAdjust technology in pregnant women, critically ill patients or those on dialysis. The safety of SmartAdjust technology has not been evaluated in these populations. Consult with your healthcare provider if any of these conditions apply to you before using SmartAdjust technology.

Warning: ALWAYS be aware of your current sensor glucose value, trust how your body feels and do not ignore symptoms of high and low glucose. Even though insulin delivery adjusts automatically in Automated Mode, with the goal of bringing your glucose level to your defined Target Glucose, severe hypoglycaemia or hyperglycaemia can still occur.

If your sensor glucose values do not match your symptoms, ALWAYS check your blood glucose using a BG meter and consider treatment and/or Sensor calibration if necessary. ALWAYS switch to Manual Mode if you feel you are receiving inaccurate sensor glucose values.

- Erroneously high sensor glucose values can cause excessive insulin delivery, leading to severe hypoglycaemia, seizure, loss of consciousness or death.
- Erroneously low sensor glucose values can cause prolonged insulin suspension, leading to hyperglycaemia, DKA or death.

If you are having symptoms that are not consistent with your blood glucose readings and you have followed all instructions described in this *Technical User Guide*, contact your healthcare provider.

Important Safety Information

Warning: AVOID administering insulin, such as by injection or inhalation, while wearing an active Pod as this could result in hypoglycaemia. The Omnipod 5 System cannot track insulin that is administered outside of the system. Consult your healthcare provider about how long to wait after manually administering insulin before you start Automated Mode.

Warning: ALWAYS monitor for symptoms of hypoglycaemia while the Activity feature is enabled. Hypoglycaemia can still occur when using the Activity feature. Follow your healthcare provider's advice on hypoglycaemia avoidance and treatment. If untreated, hypoglycaemia can lead to seizure, loss of consciousness or death.

Warning: DO NOT use Omnipod 5 System with the Dexcom G6 Sensor if you are taking hydroxyurea, a medication used in the treatment of diseases including cancer and sickle cell anaemia. Your Dexcom G6 sensor glucose values could be falsely elevated and could result in over-delivery of insulin, which can lead to severe hypoglycaemia.

CHAPTER 21

About Automated Mode

Contents

21.1 About Automated Mode	306
How insulin is calculated and delivered during Automated Mode	307
Increasing Insulin Delivery	307
Decreasing and Pausing Insulin Delivery	307
Viewing Automated Insulin Delivery	307
Adjusting Settings for Automated Insulin Delivery	308
21.2 About the Sensor in Automated Mode	309
21.3 Bolus Settings and Importance of a Bolus	310
21.4 Pod Adaptivity	311
The First Pod	311
Ongoing Use	311
21.5 About Automated Mode: Limited	312
21.6 Automated Delivery Restriction	314
Low Glucose	314
High Glucose	314
Switch to Manual Mode	315

21 About Automated Mode

21.1 About Automated Mode

Warning: AVOID administering insulin, such as by injection or inhalation, while wearing an active Pod as this could result in hypoglycaemia. The Omnipod 5 System cannot track insulin that is administered outside of the system. Consult your healthcare provider about how long to wait after manually administering insulin before you start Automated Mode.

Warning: ALWAYS be aware of your current sensor glucose value, trust how your body feels and do not ignore symptoms of high and low glucose. Even though insulin delivery adjusts automatically in Automated Mode, with the goal of bringing your glucose level to your defined Target Glucose, severe hypoglycaemia or hyperglycaemia may still occur.

If your sensor glucose values do not match your symptoms, ALWAYS check your blood glucose using a BG meter and consider treatment and/or Sensor calibration if necessary. ALWAYS switch to Manual Mode if you feel you are receiving inaccurate sensor glucose values.

- Erroneously high sensor glucose values can cause excessive insulin delivery, leading to severe hypoglycaemia, seizure, loss of consciousness or death.
- Erroneously low sensor glucose values can cause prolonged insulin suspension, leading to hyperglycaemia, DKA or death.

If you are having symptoms that are not consistent with your blood glucose readings and you have followed all instructions described in this *Technical User Guide*, contact your healthcare provider.

Caution: ALWAYS check your glucose prior to delivering a bolus so you are better informed on how much to take. Delivering a bolus without checking your glucose could result in over-delivery or under-delivery of insulin, which can lead to hypoglycaemia or hyperglycaemia.

Automated Mode is the defining feature of the Omnipod 5 System. In Automated Mode, SmartAdjust™ technology (the Omnipod 5 algorithm) predicts where your glucose will be 60 minutes into the future. SmartAdjust technology uses this information, along with your current sensor glucose value and trend, to automatically adjust insulin delivery every 5 minutes. The System's goal is to help you bring your glucose to your defined Target Glucose.

SmartAdjust technology is on the Pod itself. You will stay in Automated Mode even if the Controller running your Omnipod 5 App is out of range of the Pod. When the Pod and Controller are in range, the Pod sends its information back to the Omnipod 5 App, updating its Home screen to

show your current IOB along with the recent sensor glucose value and trend.

Note: ALWAYS bolus for meals as directed by your healthcare provider. In Automated Mode, bolus doses for meals still require your programming and delivery. Failure to deliver a bolus for meals could lead to hyperglycaemia.

How insulin is calculated and delivered during Automated Mode

The Omnipod 5 System uses your Total Daily Insulin history over the last few Pods to determine how much insulin your body needs. The calculated amount per hour is known as the Adaptive Basal Rate, which provides a baseline for automated insulin delivery.

With each Pod change, the Omnipod 5 System will learn your recent daily insulin needs and update information about your Total Daily Insulin, resulting in your Adaptive Basal Rate changing with each new Pod to better match your true insulin needs.

Using this Adaptive Basal Rate as a starting point, the System can automatically increase, decrease, or pause insulin delivery every 5 minutes to help you reach your Target Glucose.

Increasing Insulin Delivery

The System can increase insulin delivery by delivering a series of insulin microboluses (small amounts of insulin delivered every 5 minutes) to respond to elevated glucose or if it predicts your glucose to be above your Target Glucose in the next 60 minutes.

Decreasing and Pausing Insulin Delivery

The System can decrease or pause automated insulin delivery at any time if you are predicted to be below your Target Glucose or to protect against hypoglycaemia.

It will always pause insulin when the last sensor glucose value recorded was below 3.3 mmol/L (60 mg/dL).

Viewing Automated Insulin Delivery

The Sensor Graph on the Home screen shows when the Omnipod 5 System paused insulin delivery or has reached the maximum delivery. See “11.2 Viewing the Sensor Graph” on page 132.

The automated insulin delivery amount given every 5 minutes while in Automated Mode can be seen in the Auto Events tab of the History Detail screen. See “Automated Events (Auto Events)” on page 144.

The Auto Events tab shows the total amount of automated insulin delivered every 5 minutes. This tab shows all automated insulin, both your baseline Adaptive Basal Rate and any adjustment up or down due to your sensor glucose value, trend, and 60-minute prediction. The values will always be

21 About Automated Mode

small. (Remember that a basal rate of 0.60 U/hr would be like getting 0.05 U every 5 minutes.)

Note: Your sensor glucose value informs how much insulin the System will deliver in the next 5-minute time period. For example, if your sensor glucose value at 11:00 dropped to 3.2 mmol/L (56 mg/dL), SmartAdjust technology will not deliver a microbolus at 11:05. Your Auto Events tab will display 0 U at 11:05, as shown in the table below.

	Sensor (mmol/L {mg/dL})	Insulin Amount (U)
11:05	3.4 (61)	0
11:00	3.2 (56)	0.05

Adjusting Settings for Automated Insulin Delivery

While you are using Automated Mode, the main adjustable setting affecting automated insulin delivery is Target Glucose. Target Glucose is customisable from 6.1–8.3 mmol/L (110–150 mg/dL) (0.55 mmol/L or 10 mg/dL increments), and you can create up to 8 different time segments per day. As you increase the Target Glucose setting value, SmartAdjust technology will deliver less automated insulin. Changing your Target Glucose can be useful if:

- There are times of the day when you are more or less sensitive to insulin (For example, you and your healthcare provider identify a time in your day when you are more at risk of hypoglycaemia, which may require a higher Target Glucose). Your provider can help you select different Target Glucose values for different times of day.
- You would like to gradually bring your sensor glucose values down to a lower Target Glucose (For example, starting the system for the first time).

Consult with your healthcare provider before making any changes in your Target Glucose. See “Omnipod 5 Clinical Studies” on page 331 for clinical study information at each Target Glucose.

SmartBolus Calculator settings can also be adjusted to impact your Total Daily Insulin delivered and impact post-meal glucose. These settings include Insulin to Carbohydrate ratio, Correction Factor, Correct Above, Reverse Correction and Duration of Insulin Action. These all affect the bolus amounts you deliver during both Manual Mode and Automated Mode.

Note: It is important to understand that changing your Basal Programmes, Max Basal, Correction Factor or Duration of Insulin Action setting will not impact SmartAdjust technology (the Omnipod 5 algorithm).

21.2 About the Sensor in Automated Mode

Warning: ALWAYS be aware of your current sensor glucose value, trust how your body feels and do not ignore symptoms of high and low glucose. Even though insulin delivery adjusts automatically in Automated Mode, with the goal of bringing your glucose level to your defined Target Glucose, severe hypoglycaemia or hyperglycaemia may still occur.

If your sensor glucose values do not match your symptoms, ALWAYS check your blood glucose using a BG meter and consider treatment and/or Sensor calibration if necessary. ALWAYS switch to Manual Mode if you feel you are receiving inaccurate sensor glucose values.

- Erroneously high sensor glucose values can cause excessive insulin delivery, leading to severe hypoglycaemia, seizure, loss of consciousness or death.
- Erroneously low sensor glucose values can cause prolonged insulin suspension, leading to hyperglycaemia, DKA or death.

If you are having symptoms that are not consistent with your blood glucose readings and you have followed all instructions described in this *Technical User Guide*, contact your healthcare provider.

While in Automated Mode, the Omnipod 5 System relies on your current and predicted sensor glucose values to calculate automated insulin delivery. Sensor glucose values and trends may also be used by the SmartBolus Calculator in both Automated and Manual Modes.

It is important that your Sensor is functioning properly, delivering accurate values, and connecting to your Pod.

To ensure Sensor accuracy, be aware of your sensor glucose values. If you are experiencing symptoms that do not match your sensor glucose values, use a separate BG meter.

When your Pod and Sensor lose communication in Automated Mode, the System will enter Automated: Limited state. For more about Automated: Limited, see “21.5 About Automated Mode: Limited” on page 312.

If you experience frequent connectivity loss between the Pod and Sensor, see “26.3 Sensor FAQs” on page 366.

21 About Automated Mode

Connectivity issues can often be resolved by the following:

- Wear the Pod and Sensor within the line of sight in such a way that the two devices can “see” one another.
- If using Dexcom G6:
 - Check that your current, active Transmitter is paired to the Pod by checking that the Transmitter serial number (SN) stored in both the Omnipod 5 App and in the Dexcom G6 mobile App are the same.
 - Check that your active Transmitter is not paired with a Dexcom G6 receiver or another medical device. When using Omnipod 5, the Pod is the only medical device the Transmitter can pair with. You must use the Dexcom G6 mobile App on a smartphone to manage Sensor alarms and to start and stop Sensors and Transmitters.
- If using FreeStyle Libre 2 Plus:
 - Check that your Sensor was started in the Omnipod 5 App. If your Sensor was started with another device, you will not be able to use the Sensor with Omnipod 5.

21.3 Bolus Settings and Importance of a Bolus

In Automated Mode, the Omnipod 5 System automatically delivers insulin every 5 minutes. However, you still need to deliver a bolus dose for meals. For information on how to deliver a bolus, see “SmartBolus Calculator” on page 207.

When delivering a bolus, it is recommended to:

- Tap **USE Sensor** to use your sensor glucose value in the SmartBolus Calculator. This will ensure that your Sensor trend is included in the calculations and necessary adjustments are made to account for the trend.
- Review the SmartBolus Calculator calculations for accuracy. If the calculations show an amount you are not expecting, cancel the bolus and begin again.
- Always look for the progress bar to confirm that delivery has begun before exiting the Omnipod 5 App.

Note: If you leave the Omnipod 5 App for more than 5 minutes while making changes to your bolus delivery, you will lose the information you have entered into the SmartBolus Calculator.

21.4 Pod Adaptivity

In Automated Mode, automated insulin delivery adapts to your changing needs as you wear the System. As you use the Omnipod 5 System and gather insulin delivery history, SmartAdjust technology will automatically update your next Pod with information from your last few Pods about your recent Total Daily Insulin (TDI).

Your baseline Adaptive Basal Rate is based on how much Total Daily Insulin you have needed over the past few weeks. With each Pod change, SmartAdjust technology uses this updated TDI to set a new Adaptive Basal Rate for you.

When sensor glucose values and trend are available, SmartAdjust technology will also adjust this rate up or down every 5 minutes in response to your current and predicted glucose.

The First Pod

During your first Pod wear (or if you've gone 30 days or longer between Pods), since no recent history is available, the Omnipod 5 System estimates your Total Daily Insulin by looking at your active Basal Programme (from Manual Mode). SmartAdjust technology sets a starting baseline Adaptive Basal Rate from that estimated TDI. That is the starting rate that will be adjusted up or down based on your current and predicted glucose and trend.

The System also sets a limit on how much insulin the first Pod's 5-minute adjustments can deliver for your safety.

At your next Pod change, if at least 48 hours of history was collected, SmartAdjust technology will start using your insulin delivery history instead of its original estimate to update the Adaptive Basal Rate.

Ongoing Use

With each Pod change, for as long as you wear the System, updated insulin delivery information is sent and saved in the Omnipod 5 App so that the next Pod that is started is updated with the new Adaptive Basal Rate.

Note: Your Total Daily Insulin (TDI) includes all of the insulin delivered in either Automated or Manual Mode. You can view your TDI for each day by navigating to Menu button (☰) > History Detail and looking at the Total Insulin value.

21.5 About Automated Mode: Limited

Warning: ALWAYS be aware of your current sensor glucose value, trust how your body feels and do not ignore symptoms of high and low glucose. Even though insulin delivery adjusts automatically in Automated Mode, with the goal of bringing your glucose level to your defined Target Glucose, severe hypoglycaemia or hyperglycaemia may still occur.

If your sensor glucose values do not match your symptoms, ALWAYS check your blood glucose using a BG meter and consider treatment and/or Sensor calibration if necessary. ALWAYS switch to Manual Mode if you feel you are receiving inaccurate sensor glucose values.

- Erroneously high sensor glucose values can cause excessive insulin delivery, leading to severe hypoglycaemia, seizure, loss of consciousness or death.
- Erroneously low sensor glucose values can cause prolonged insulin suspension, leading to hyperglycaemia, DKA or death.

If you are having symptoms that are not consistent with your blood glucose readings and you have followed all instructions described in this *Technical User Guide*, contact your healthcare provider.

At times, your Pod and Sensor may lose communication while you are in Automated Mode. There are several reasons this could happen, including:

- The Pod and Sensor not being within the line of sight on your body.
- Temporary loss of communication due to environmental interference.
- Sensor warm-up or required calibration (if applicable to your Sensor).
- Your Transmitter is still paired with a Dexcom G6 receiver or other medical device.

When this occurs, SmartAdjust technology can no longer adjust your automated insulin delivery based on glucose because the Pod is not receiving updated glucose information from the Sensor.

After 20 minutes of the Pod not receiving sensor glucose values, the System enters a state of Automated Mode called Automated: Limited. The Omnipod 5 App will display “Limited” on the Home screen. Your System will remain in Automated: Limited until Sensor communication is restored or the Sensor warm-up period ends.

When the System enters Automated: Limited state, SmartAdjust technology bases its insulin delivery on the following:

- It looks at your basal rate in Manual Mode at this time of day and your Adaptive Basal Rate for this Pod and chooses the lower of the two values every 5 minutes. In this way, SmartAdjust technology never gives more than the Basal Programme that would be active during Manual Mode.
- If SmartAdjust technology had paused your insulin before the Pod lost connection with your Sensor, it will continue to pause insulin up to 40 minutes for a total of 1 hour paused. After 1 hour of no sensor glucose information, it will resume your insulin at your adaptive or Manual basal rates, whichever is lower.
- Without sensor glucose information, the rate delivered in Automated: Limited will not adjust up or down for current or predicted glucose.

After an hour of missed sensor glucose values, the Missing Sensor Glucose Values Advisory Alarm is presented. This alarm will repeat every 15 minutes until acknowledged and every 60 minutes until Sensor communication is restored. For more information on this alarm, see “ Missing Sensor Glucose Values” on page 328.

The System also enters Limited state after receiving the Automated Delivery Restriction Advisory Alarm. For more information about Automated Delivery Restriction, see page 314 .

You may also choose to switch to Manual Mode to start your Basal Programme. See “22.2 Switching from Automated Mode to Manual Mode” on page 320.

Check to see if there are any Sensor actions that you need to take to re-establish communication between the Pod and Sensor.

If you use Dexcom G6 as your Sensor, check your Dexcom G6 App. See your *Dexcom G6 CGM System Instructions for Use*.

If you use FreeStyle Libre 2 Plus as your Sensor, check for notifications related to FreeStyle Libre 2 Plus in your Omnipod 5 App.

Note: Automated: Limited state can occur due to a loss of communication between the Sensor and Pod. If you use Dexcom G6, it is possible that your Dexcom G6 App is still receiving sensor glucose values. Open your Dexcom G6 App to check.

21.6 Automated Delivery Restriction

There may be times when the System has been working to bring your glucose into range but has not seen your glucose change the way it expected. In this case, it will switch to Automated: Limited state.

During these times, you'll see an orange bar on your Sensor Graph for "Insulin max reached" or a red bar for "Insulin paused". The System will show an Advisory Alarm that says "Automated Delivery Restriction".

For more information about this alarm, see " Automated Delivery Restriction" on page 326.

Low Glucose

If your glucose has been trending low, SmartAdjust technology may have paused insulin.

If there has been little to no impact to your sensor glucose value from pausing, the System assumes there may be a problem you need to troubleshoot. Pausing insulin for too long could put you at risk of hyperglycaemia.

The Automated Delivery Restriction can let you know that you need to step in and check the following:

- Is your Sensor reporting your glucose accurately? Check your BG with a BG meter to confirm.
- Has your glucose been low despite treatment? Consider eating additional fast-acting carbs.

High Glucose

If your glucose has been trending high, SmartAdjust technology may have delivered the maximum amount of insulin microboluses allowed by the System.

Note: This maximum amount is different than your Max Basal setting in Manual Mode. Adjusting your Max Basal setting in Manual Mode will not impact the amount that SmartAdjust technology can deliver in Automated Mode. This insulin max value is unique to each person and based on your recent Total Daily Insulin use. It may change over time as your System continually adapts with each Pod change. You cannot directly impact this setting.

If there has been little to no impact to your sensor glucose value from delivering at the insulin max, the System assumes there may be a problem you need to troubleshoot. Delivering too much insulin for too long could put you at risk of hypoglycaemia.

The Automated Delivery Restriction can let you know that you need to step in and check the following:

- Is your Sensor reporting your glucose accurately? Check your BG with a BG meter to confirm. You may need to replace your Sensor.
- Could there be a problem with your Pod or cannula? Check that your Pod is securely applied, and that there are no signs of wetness or leaking around the adhesive. Check for ketones. You may need to replace your Pod.
- Do you need more insulin? Tap the bolus button, tap Use Sensor on the Bolus screen, and see if additional insulin is recommended. You may need a correction bolus.

Switch to Manual Mode

When the Automated Delivery Restriction alarm appears, the System will ask you to switch to Manual Mode for 5 minutes or longer. This step allows the System to know that you are aware of the situation and considering action. While in Manual Mode, you can check BG, review the Sensor Graph and troubleshoot your Sensor and Pod. You can then return to Automated Mode by tapping Menu button () > Switch Modes.

Note: If you get this alarm often, your Target Glucose or bolus settings may need to be adjusted. Consult your healthcare provider for help adjusting these settings on Omnipod 5.

This page intentionally left blank.

CHAPTER 22

Switching Between Manual Mode and Automated Mode

Contents

22.1 Switching from Manual Mode to Automated Mode	318
Before you begin	318
To switch to Automated Mode	319
22.2 Switching from Automated Mode to Manual Mode	320
To switch to Manual Mode	320

22.1 Switching from Manual Mode to Automated Mode

Warning: ALWAYS be aware of your current sensor glucose value, trust how your body feels and do not ignore symptoms of high and low glucose. Even though insulin delivery adjusts automatically in Automated Mode, with the goal of bringing your glucose level to your defined Target Glucose, severe hypoglycaemia or hyperglycaemia may still occur.

If your sensor glucose values do not match your symptoms, ALWAYS check your blood glucose using a BG meter and consider treatment and/or Sensor calibration if necessary. ALWAYS switch to Manual Mode if you feel you are receiving inaccurate sensor glucose values.

- Erroneously high sensor glucose values can cause excessive insulin delivery, leading to severe hypoglycaemia, seizure, loss of consciousness or death.
- Erroneously low sensor glucose values can cause prolonged insulin suspension, leading to hyperglycaemia, DKA or death.

If you are having symptoms that are not consistent with your blood glucose readings and you have followed all instructions described in this *Technical User Guide*, contact your healthcare provider.

Before you begin

First, make sure you have an active Pod and connected Sensor. See “Activating and Changing Your Pod” on page 77 and Chapters 19 and 20 for information on connecting your Sensor to the System.

Do the following, if necessary:

- Cancel your Temp Basal or Extended Bolus, if either is running. See “7.3 Cancelling a Temp Basal or Temp Basal Preset” on page 105 or “16.4 Canceling a Bolus in Progress” on page 215.
- Start insulin, if it is paused. See “9.3 Starting Insulin Delivery” on page 120.

To switch to Automated Mode

To switch from Manual Mode to Automated Mode:

1. From the Home screen, tap Menu button (☰) > Switch Mode.

Note: If the screen displays a red circle with an exclamation mark and SWITCH TO AUTOMATED is disabled (greyed out), take the corrective action described on the screen before you try again.

2. Tap SWITCH.

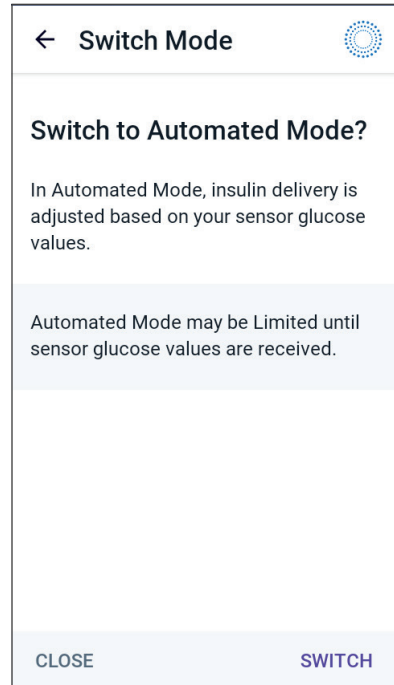

22.2 Switching from Automated Mode to Manual Mode

When you switch from using Automated Mode to using Manual Mode, basal insulin will be delivered based on the Basal Programme scheduled for the current time. If your Sensor is connected, you will still be able to view these values and use them in the SmartBolus Calculator while in Manual Mode.

Before you begin, do the following:

- Cancel the Activity feature, if it is enabled. See “23.3 Cancelling the Activity Feature” on page 323.

To switch to Manual Mode

1. From the Home screen, tap Menu button (☰) > Switch Mode.

Note: If the screen displays a red circle with an exclamation mark and SWITCH TO MANUAL is disabled (greyed out), take the corrective action described on the screen before you try again.

2. Tap SWITCH.

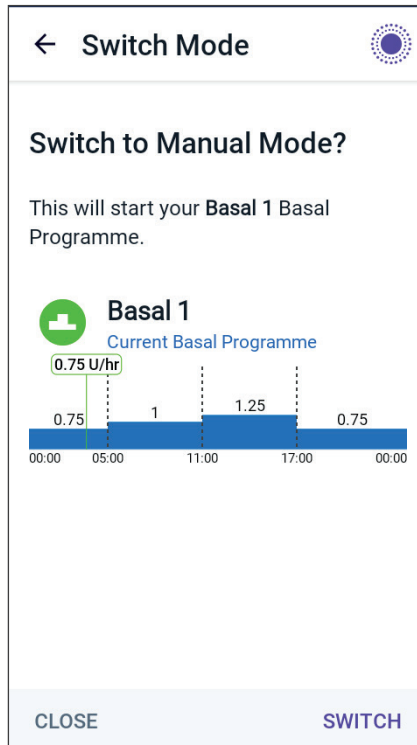

CHAPTER 23

Activity Feature

Contents

23.1 About the Activity Feature	322
23.2 Starting the Activity Feature	323
23.3 Cancelling the Activity Feature	323

23.1 About the Activity Feature

Warning: ALWAYS monitor for symptoms of hypoglycaemia while the Activity feature is enabled. Hypoglycaemia can still occur when using the Activity feature. Follow your healthcare provider's advice on hypoglycaemia avoidance and treatment. If untreated, hypoglycaemia can lead to seizure, loss of consciousness or death.

While in Automated Mode, you cannot start a Temp Basal or manually pause insulin delivery. The Omnipod 5 System provides an option for modified Automated insulin delivery through the Activity feature. The Activity feature can be useful in times when you need less insulin, for example, when you are exercising.

While Activity is enabled, the Omnipod 5 System does the following:

- Reduces Automated insulin delivery.
- Sets your Target Glucose to 8.3 mmol/L (150 mg/dL), regardless of your target settings.

With the Activity feature enabled, you can still deliver a bolus as you normally would.

Note: The Activity feature does not change the Target Glucose used in bolus calculations.

Activity can be set for a duration of 1–24 hours, in increments of 1 hour. You can cancel Activity at any time. Upon cancellation or expiry of the defined time period, full automated insulin delivery starts on its own and SmartAdjust technology returns to using the Target Glucose defined in your settings.

The Activity feature ends if the Pod is deactivated. You need to re-enter Automated Mode and then enable Activity with your new Pod.

Talk to your healthcare provider about the timing of starting the Activity feature to address your anticipated period of decreased insulin needs.

Note: In the event of a loss of Pod and Sensor communication and the Omnipod 5 System enters Limited state, the Activity feature remains enabled.

Note: You may see an increase in your displayed IOB when the Activity feature starts and a decrease in your IOB when the Activity feature time period ends because of the way insulin is calculated.

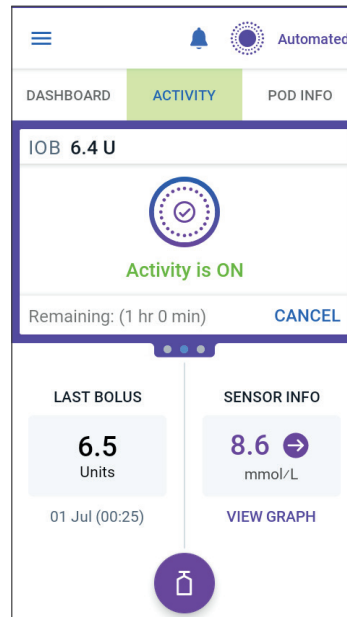

23.2 Starting the Activity Feature

Before you begin, do the following:

- Switch to Automated Mode if currently using Manual Mode. See “22.1 Switching from Manual Mode to Automated Mode” on page 318.

To enable Activity:

1. Navigate to:
Menu button (≡) > Activity
2. Tap the Duration field and select the Activity feature duration.
3. Tap CONFIRM.
4. From the Confirmation screen, tap START.
The INSULIN tab changes to a green ACTIVITY tab when the Activity feature is enabled.

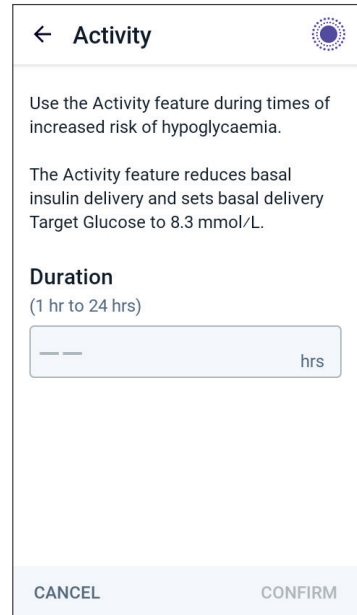

23.3 Cancelling the Activity Feature

The Activity feature automatically stops at the end of the selected duration; Automated Mode continues, using the Target Glucose defined in your user settings. The Pod beeps when the Activity feature time period completes or when you cancel it.

To cancel Activity before the end of its time period:

1. Navigate to the Home screen ACTIVITY tab.
2. Tap CANCEL.
3. Tap YES to confirm cancellation.
The Omnipod 5 App cancels Activity and full Automated insulin delivery starts.

Note: You may see a decrease in Insulin on Board (IOB) when cancelling the Activity feature.

This page intentionally left blank.

CHAPTER 24

Automated Mode Alarms

Contents

24.1 Advisory Alarm List.....	326
! Automated Delivery Restriction	326
! Missing Sensor Glucose Values	328

24 Automated Mode Alarms

24.1 Advisory Alarm List

Advisory Alarms inform you of a situation that needs your attention in the near future.

! Automated Delivery Restriction

Only occurs in Automated Mode.

Omnipod 5 App Screens:

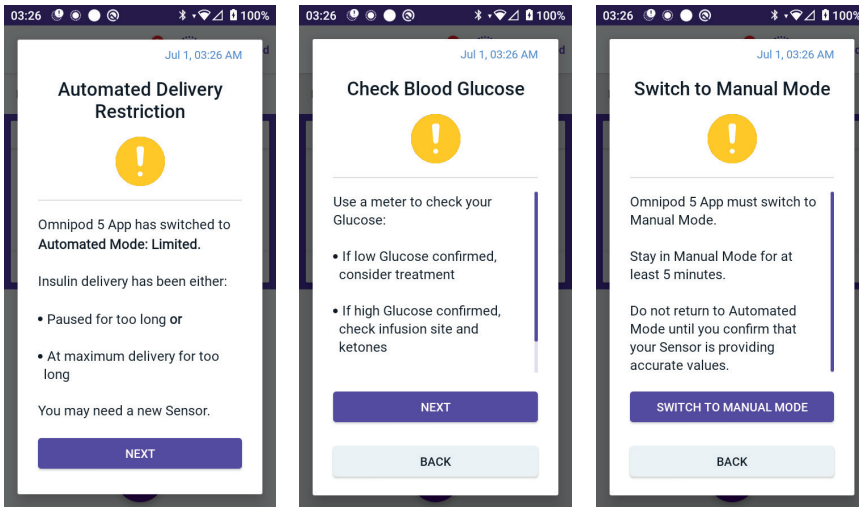

Lock Screen:



Cause	Insulin was either paused for too long or at maximum delivery for too long while the Omnipod 5 System was in Automated Mode.
Tone (Pod)	<ul style="list-style-type: none"> • 6-beep tone, repeats once every minute for 3 minutes • Pattern repeats every 15 minutes
Vibration/Tone (Controller)	<ul style="list-style-type: none"> • 3-second tone • 3-second vibration • Vibration and tone repeat every 15 minutes until acknowledged
What to do	<ol style="list-style-type: none"> 1. Tap NEXT to see the next screen. 2. Use a BG meter to confirm your blood glucose. <ul style="list-style-type: none"> • If low confirmed, consider treatment. • If high confirmed, check infusion (Pod) site and ketones. • If your sensor glucose value is not what you expected, you may need to or replace your Sensor. 3. Tap NEXT after you confirm your blood glucose. 4. Tap SWITCH TO MANUAL MODE, then stay in Manual Mode for at least five minutes.

While in Manual Mode, you can check your Sensor Graph to find out whether your insulin has been paused or has been at a maximum for a long time.

After at least 5 minutes of Manual Mode, you can return to Automated Mode after you have confirmed your sensor glucose values are accurate.

For more information about Automated Mode: Limited state, see “21.5 About Automated Mode: Limited” on page 312.

24 Automated Mode Alarms

! Missing Sensor Glucose Values

Only occurs in Automated Mode.

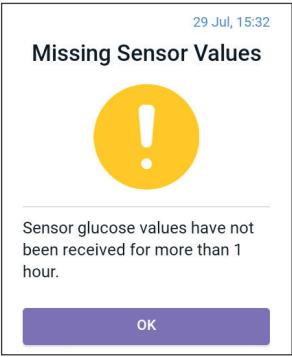
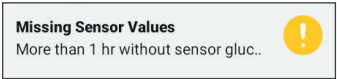
Screen Alert	Description
<p>Omnipod 5 App:</p> 	<p>Why it occurs: The Pod has not received sensor glucose values for more than one hour. The system will continue to operate in Automated Mode: Limited state until sensor glucose values are received or until you switch to Manual Mode.</p> <p>Pod sound:</p> <ul style="list-style-type: none">• 3-beep tone• Repeats every 60 minutes <p>Controller sound and vibration:</p> <ul style="list-style-type: none">• 3-second tone• 3-second vibration• Vibration and tone repeat every 15 minutes until acknowledged• If sensor glucose values have still not been received after 60 minutes, a new notification will be generated.
<p>Lock Screen:</p> 	<p>What to do:</p> <ul style="list-style-type: none">➤ Tap OK to acknowledge the alert.

For more information on Automate Mode: Limited state, see “21.5 About Automated Mode: Limited” on page 312.

If you use Dexcom G6, check your Dexcom G6 App to see if there are sensor glucose values present or if the cause of the loss of communication is related to the Sensor. Examples to look for within the Dexcom G6 App include Sensor error/expiry, Transmitter error/expiry, Sensor warm-up or signal loss alert.

If the Dexcom G6 App is receiving sensor glucose values, there may be a temporary communication issue between your Pod and the Dexcom G6. You may decide to switch to Manual Mode or wait for sensor glucose values to be received while in Automated Mode: Limited state. If this is happening often, check to see if the Pod and Sensor are located on your body at least 8 cm (3 in) apart and within the line of sight. If not, when you remove one, position the new one so that your Pod and Sensor are within the line of sight of one another.

Note: For information about your Dexcom G6 App, refer to your *Dexcom G6 CGM System Instructions for Use*.

Note: If you use a FreeStyle Libre 2 Plus Sensor, check your Omnipod 5 App to see if there are sensor glucose values present or if the cause of the loss of communication is related to the Sensor. Check that your Sensor is securely applied to the back of your upper arm.

If you use FreeStyle Libre 2 Plus, there may be a temporary communication issue between your Pod and the FreeStyle Libre 2 Plus Sensor. You may decide to switch to Manual Mode or wait for a sensor glucose value to be received while in Automated Mode: Limited state. If this is frequently occurring, check to see if the Pod and Sensor are located on your body at least 2.5 cm (1 in) apart and within the line of sight. If not, when you remove one, make sure to position the new one so that your Pod and Sensor are within the line of sight of one another.

Note: For information about your FreeStyle Libre 2 Plus Sensor, refer to your *FreeStyle Libre 2 Plus User's Manual*.

This page intentionally left blank.

CHAPTER 25

Omnipod 5 Clinical Studies

Contents

25.1 Studies in Children, Adolescents and Adults with Type 1 Diabetes	332
Demographics	333
Change in A1C Analysed by Baseline A1C.....	337
Glycaemic Results by Baseline Treatment	338
Insulin Requirements	339
Body Mass Index Results.....	340
Omnipod 5 System Use.....	340
Adverse Events	340
Glycaemic Results at Target Glucose Settings in Pivotal Study	342
25.2 Studies in Very Young Children with Type 1 Diabetes	347
Demographics	348
Glycaemic Results	349
Change in A1C Analysed by Baseline A1C	351
Glycaemic Results by Baseline Treatment	351
Insulin Requirements	352
Body Mass Index Results.....	352
Omnipod 5 System Use	352
Adverse Events	353
Glycaemic Results at Target Glucose Settings	354

25.1 Studies in Children, Adolescents and Adults with Type 1 Diabetes

Omnipod 5 Pivotal Study in Children, Adolescents and Adults (6–70 years)

The goal of the US-based pivotal study of the Omnipod 5 System was to assess the safety and effectiveness of the system. This single-arm, multicentre, prospective study enrolled 112 children (6 to 13.9 years) and 128 adolescents and adults (14 to 70 years). A 2-week standard therapy phase (usual insulin regimen) was followed by 3 months of the Omnipod 5 System use in Automated Mode with a Dexcom G6 Sensor. The primary analysis consisted of A1C and sensor glucose time in range (3.9–10 mmol/L, 70–180 mg/dL) results. The primary safety endpoints included an assessment of severe hypoglycaemia and diabetic ketoacidosis (DKA) events. An analysis of the secondary endpoints and additional metrics was also performed. An analysis of the primary, secondary and safety results are presented in the tables below.

Of the 240 participants enrolled, 98% completed the trial (111 children and 124 adolescents and adults). The study population consisted of people with type 1 diabetes for at least 6 months. All participants were required to have an A1C < 10.0% at screening. Participants < 18 years had to be living with a parent or legal guardian. No participants with the following conditions were enrolled:

- History of severe hypoglycaemia or DKA in the past 6 months.
- Sickle cell disease, adrenal insufficiency, eating disorder, abnormal kidney function (eGFR < 45), haemophilia or any other bleeding disorders, untreated thyroid disease.
- History of cardiovascular disease including coronary artery disease, heart attack and cardiac intervention procedure or coronary bypass surgery in the past year.
- Abnormal ECG in participants > 50 years or diagnosed with diabetes > 20 years.
- Plans to receive a blood transfusion during study.
- Taking oral or injectable steroids or diabetes medications other than metformin and insulin.
- Pregnant or lactating women.

The safety and effectiveness of the Omnipod 5 System in users with the conditions above is unknown. Please note that the study exclusion list above is condensed and does not include every exclusion criterion. The

trial was registered at clinicaltrials.gov, a national database of clinical trials in the United States, with ID number NCT04196140. Full details of the study criteria can be found there.

Demographics

Baseline characteristics including demographics of the participants at the start of the 3-month Omnipod 5 treatment phase are provided in the table below.

Baseline Characteristics at Omnipod 5 Treatment Phase Start (N=240)

Characteristic	Children (6 to 13.9 years)	Adolescents & Adults (14 to 70 years)
n	112	128
Age (years) ± SD	10.3 ± 2.2	36.9 ± 13.9
Duration of diabetes (years)	4.7 ± 2.6	17.9 ± 11.6
A1C [§]	7.67% ± 0.95%	7.16% ± 0.86%
Daily insulin dose (U/kg) [†]	0.85 ± 0.24	0.61 ± 0.22
Body mass index (BMI)	18.6 ± 3.2	26.6 ± 4.7
Female sex	60 (53.6%)	78 (60.9%)
Previous [‡] or current continuous glucose monitor (CGM) use	108 (96.4%)	126 (98.4%)
Previous [‡] or current pump use	100 (89.3%)	115 (89.8%)
Race/Ethnicity [‡]		
White	110 (98.2%)	118 (92.2%)
Hispanic or Latino	8 (7.1%)	10 (7.8%)
Black or African American	5 (4.5%)	5 (3.9%)
Asian	3 (2.7%)	2 (1.6%)
Native Hawaiian or other Pacific Islander	1 (0.9%)	0 (0.0%)
American Indian or Alaska Native	0 (0.0%)	4 (3.1%)

Plus-minus values are average ± standard deviation; results reported with number in brackets afterwards represent the number of participants (% of participants).

[§] Glycated haemoglobin determined from laboratory assessment.

[†] Baseline Total Daily Insulin dose was determined from data collected during the standard therapy phase.

[‡] Previous use is defined as having used the device for any duration in the past.

[‡] Race and ethnicity were reported by the participants. Groups are not mutually exclusive.

Glycaemic Results

The tables below include information on the primary and secondary glycaemic results from the standard therapy phase compared to the 3-month Omnipod 5 System treatment phase. The primary results of the study included change in average A1C% and % time in range (3.9–10 mmol/L, 70–180 mg/dL). Adolescents, adults and children experienced improvements in overall A1C and time in range after 3 months of Omnipod 5 System use. This was achieved with a reduction of time > 10 mmol/L (> 180 mg/dL) in adolescents, adults, and children as well as a reduction in median time < 3.9 mmol/L (< 70 mg/dL) in adolescents and adults.

Some limitations to the study include: 1) single-arm design with no control group, which could lead to an over-estimate of glycaemic improvement; 2) the standard therapy phase was shorter than the Omnipod 5 System phase; 3) minimal use of the 7.8 and 8.3 mmol/L (140 and 150 mg/dL) Target Glucose settings in adults and adolescents limited the assessment of glycaemic results at those settings and, for that reason, results at these target settings were not included in this *Technical User Guide*.

Glycaemic Results Overall (24 hours)

Characteristic	Children (6 to 13.9 years) (n=112)			Adolescents & Adults (14 to 70 years) (n=128)		
	Standard Therapy	Omnipod 5	Change	Standard Therapy	Omnipod 5	Change
Avg A1C% (std dev)	7.67% (0.95%)	6.99% (0.63%)	-0.71%*	7.16% (0.86%)	6.78% (0.68%)	-0.38%*
Avg % time 3.9–10 mmol/L, 70–180 mg/dL (std dev)	52.5% (15.6%)	68.0% (8.1%)	15.6%*	64.7% (16.6%)	73.9% (11.0%)	9.3%*
Avg sensor glucose, mmol/L, mg/dL (std dev)	10.2, 183 (1.8, 32)	8.9, 160 (0.8, 15)	-1.3, -23*	8.9, 161 (1.6, 28)	8.6, 154 (0.9, 17)	-0.4, -8*
Avg standard deviation of sensor glucose, mmol/L, mg/dL (std dev)	3.8, 68 (0.7, 13)	3.3, 60 (0.6, 10)	-0.5, -9*	3.2, 57 (0.8, 14)	2.7, 49 (0.6, 11)	-0.4, -8*
Avg coefficient of variation of sensor glucose, % (std dev)	37.5% (5.1%)	37.0% (3.9%)	-0.4%	35.2% (5.7%)	31.7% (4.7%)	-3.5%*
% Time in Glucose Range						
Median % < 3 mmol/L, < 54 mg/dL (Q1, Q3)	0.10% (0.00, 0.41)	0.23% (0.08, 0.42)	0.04%	0.22% (0.00, 0.77)	0.17% (0.06, 0.28)	-0.08%*
Median % < 3.9 mmol/L, < 70 mg/dL (Q1, Q3)	1.38% (0.42, 2.67)	1.48% (0.65, 2.23)	0.06%	2.00% (0.63, 4.06)	1.09% (0.46, 1.75)	-0.89%*
Avg % > 10 mmol/L, > 180 mg/dL (std dev)	45.3% (16.7%)	30.2% (8.7%)	-15.1%*	32.4% (17.3%)	24.7% (11.2%)	-7.7%*
Avg % ≥ 13.9 mmol/L, ≥ 250 mg/dL (std dev)	19.1% (13.1%)	9.6% (5.4%)	-9.4%*	10.1% (10.5%)	5.8% (5.5%)	-4.3%*
Avg % ≥ 16.7 mmol/L, ≥ 300 mg/dL (std dev)	8.5% (8.9%)	3.5% (2.9%)	-5.1%*	3.7% (5.5%)	1.7% (2.5%)	-2.0%*

Most of the primary and secondary results are presented as averages (avg) with standard deviation (std dev) values in brackets. Time in range < 3.9 mmol/L, < 70 mg/dL and < 3 mmol/L, < 54 mg/dL is reported as medians with interquartile ranges in brackets (Q1, Q3). The median is the middle number in an ascending list of numbers and the interquartile range represents the middle 50% of values. *Change between the standard therapy phase and the Omnipod 5 System phase was statistically significant.

25 Overview of Omnipod 5 System Pivotal Clinical Study

Glycaemic Results Overnight (00:00 to 06:00)

Characteristic	Children (6 to 13.9 years) (n=112)			Adolescents & Adults (14 to 70 years) (n=128)		
	Standard Therapy	Omnipod 5	Change	Standard Therapy	Omnipod 5	Change
Avg % time 3.9–10 mmol/L, 70–180 mg/dL (std dev)	55.3% (19.0%)	78.1% (10.8%)	22.9%*	64.3% (19.5%)	78.1% (13.9%)	13.8%*
Avg sensor glucose, mmol/L, mg/dL (std dev)	9.8, 177 (1.9, 35)	8.3, 149 (0.9, 17)	-1.6, -29*	8.9, 160 (1.9, 34)	8.3, 149 (1.2, 21)	-0.6, -11*
Avg standard deviation of sensor glucose, mmol/L, mg/dL (std dev)	3.4, 61 (0.8, 15)	2.7, 48 (0.7, 12)	-0.7, -13*	3.1, 56 (0.9, 17)	2.4, 44 (0.7, 13)	-0.7, -12*
Avg coefficient of variation of sensor glucose, % (std dev)	34.6% (7.1%)	31.9% (5.6%)	-2.8%*	35.0% (7.9%)	28.9% (5.8%)	-6.2%*
Percentage time in glucose range, %						
Median % < 3 mmol/L < 54 mg/dL (Q1, Q3)	0.00% (0.00, 0.30)	0.09% (0.02, 0.32)	0.02%	0.00% (0.00, 1.06)	0.09% (0.02, 0.30)	0.00%*
Median % < 3.9 mmol/L, < 70 mg/dL (Q1, Q3)	0.78% (0.00, 2.84)	0.78% (0.37, 1.49)	0.01%*	2.07% (0.50, 5.54)	0.82% (0.31, 1.62)	-0.86%*
Avg % > 10 mmol/L, > 180 mg/dL (std dev)	42.2% (20.0%)	20.7% (10.8%)	-21.5%*	32.1% (20.2%)	20.7% (14.1%)	-11.3%*
Avg % ≥ 13.9 mmol/L, ≥ 250 mg/dL (std dev)	16.3% (15.0%)	5.4% (5.1%)	-10.9%*	10.6% (12.7%)	4.8% (7.0%)	-5.7%*
Avg % ≥ 16.7 mmol/L, ≥ 300 mg/dL (std dev)	6.7% (9.1%)	1.8 (2.5%)	-4.8%*	4.2% (8.0%)	1.5% (3.1%)	-2.7%*

*Change between the standard-therapy phase and the Omnipod 5 System phase was statistically significant.

Change in A1C Analysed by Baseline A1C

The table below provides information on the average change in A1C% from baseline to the end of the 3-month Omnipod 5 System treatment phase analysed by baseline A1C% in children (6 to 13.9 years) and adolescents and adults (14 to 70 years). Adolescents, adults and children experienced a reduction in A1C after 3 months of Omnipod 5 System use regardless of baseline A1C < 8% or ≥ 8% category.

Subgroup Analysis of Change in Average A1C(%) by Baseline A1C(%)

Adolescents & Adults	Baseline A1C <8% (n=105)			Baseline A1C ≥8% (n=23)		
	Baseline	Omnipod 5	Change	Baseline	Omnipod 5	Change
A1C% (std dev) [‡]	6.86% (0.59%)	6.60% (0.53%)	-0.27%*	8.55% (0.42%)	7.63% (0.67%)	-0.91%*
Children	Baseline A1C <8% (n=73)			Baseline A1C ≥8% (n=39)		
	Baseline	Omnipod 5	Change	Baseline	Omnipod 5	Change
A1C% (std dev)	7.11% (0.50%)	6.69% (0.44%)	-0.45%*	8.73% (0.63%)	7.56% (0.54%)	-1.18%*

*Change between the standard therapy phase and the Omnipod 5 System phase was statistically significant.

[‡]Average A1C values are reported with standard deviation values in brackets.

Glycaemic Results by Baseline Treatment

The table below provides information on the average glycaemic results at baseline (or during standard therapy phase) and the 3-month Omnipod 5 System treatment phase analysed by baseline treatment (standard therapy). Standard therapy consisted of multiple daily insulin injections (MDI) or insulin pump use. Time in range (3.9–10 mmol/L, 70–180 mg/dL) and A1C were improved after 3 months of Omnipod 5 System use regardless of baseline treatment type. After 3 months of Omnipod 5 System use, time < 3.9 mmol/L (< 70 mg/dL) improved in adolescents and adults regardless of baseline therapy, but remained unchanged in children.

Subgroup Analysis of Average Glycaemic Results by Baseline Treatment in Children (6 to 13.9 years)

Characteristic	MDI (n=13)		Insulin Pump (n=99)	
	Standard Therapy	Omnipod 5	Standard Therapy	Omnipod 5
% Time in range 3.9–10 mmol/L, 70–180 mg/dL	52%	69%*	53%	68%*
% Time < 3.9 mmol/L (< 70 mg/dL)	1.54%	1.41%	1.38%	1.49%
A1C%	7.7%	6.7%*	7.7%	7.0%*

*Change between the standard therapy phase and the Omnipod 5 System phase was statistically significant.

† Values presented for % Time < 3.9 mmol/L (< 70 mg/dL) are medians; the remaining values in the table are averages.

Subgroup Analysis of Average Glycaemic Results by Baseline Treatment in Adolescents and Adults (14 to 70 years)

Characteristic	MDI (n=20)		Insulin Pump (n=105)	
	Standard Therapy	Omnipod 5	Standard Therapy	Omnipod 5
% Time in range 3.9–10 mmol/L, 70–180 mg/dL	60%	72%*	66%	74%*
% Time < 3.9 mmol/L (< 70 mg/dL)	2.38%	0.79%*	1.93%	1.16%*
A1C%	7.6%	7.0%*	7.1%	6.7%*

*Change between baseline/standard therapy and the Omnipod 5 System phase was statistically significant..

† Values presented for % Time below < 3.9 mmol/L (< 70 mg/dL) are medians; the remaining values in the table are averages.

An analysis by baseline demographic characteristics, including those mentioned in the subgroup analyses above, demonstrated similar glycaemic improvement to the overall study population. Please note that the study was not designed to determine differences in benefit or risk from each subgroup.

Insulin Requirements

The table below provides information on the average insulin requirements during the standard therapy phase and the 3-month Omnipod 5 System phase. Total Daily Insulin requirements increased in children and decreased slightly in adolescents and adults.

Characteristic	Children (6 to 13.9 years) (n=112)			Adolescents & Adults (14 to 70 years) (n=128)		
	Standard Therapy	Omnipod 5	Change	Standard Therapy	Omnipod 5	Change
Avg Total Daily Insulin (U) (std dev)	34.4 (17.5)	37.2 (19.6)	2.9*	48.2 (21.0)	46.4 (18.1) -	-1.8*
Avg Total Daily Insulin, U/kg (std dev)	0.85 (0.24)	0.92 (0.25)	0.07*	0.61 (0.22)	0.59 (0.21)	-0.02*
Avg total daily basal insulin, U/kg (std dev)	0.36 (0.13)	0.47 (0.15)	0.10*	0.31 (0.11)	0.30 (0.11)	-0.01
Avg total daily bolus insulin, U/kg (std dev)	0.48 (0.18)	0.45 (0.13)	-0.03*	0.31 (0.16)	0.29 (0.12)	-0.01

*Change between the standard-therapy phase and the Omnipod 5 System phase was statistically significant.

Body Mass Index Results

The table below provides information on the average body mass index (BMI), which is a measure of weight adjusted for height, and BMI z-score, which is a measure of weight adjusted for height, sex and age, during the standard therapy phase and the 3-month Omnipod 5 System phase in children. Although BMI increased in children, the BMI z-score remained unchanged.

Characteristic	Children (6 to 13.9 years) n=112		
	Standard Therapy	Omnipod 5	Change
BMI, kg/m ² (std dev)	18.6 (3.2)	19.2 (3.6)	0.54*
BMI z-score (std dev)	0.4 (0.8)	0.4 (0.8)	0.03

*Change between the standard-therapy phase and the Omnipod 5 System phase was statistically significant.

Omnipod 5 System Use

The table below provides information on the average % of time study participants used the Omnipod 5 System in Automated Mode.

Per Cent Time Spent in Automated Mode

	Children (6 to 13.9 years) n=112	Adolescents & Adults (14 to 70 years) n=128
% Time in Automated Mode (std dev)	95.2% (4.0%)	94.8% (6.0%)

Adverse Events

The table below provides a full list of the adverse events that occurred during the 3-month Omnipod 5 System treatment phase. There were 3 severe hypoglycaemia events not attributable to the Omnipod 5 System Automated insulin delivery or system malfunction and 1 DKA event from a suspected infusion site failure. Other related, but non-glycaemic adverse events included infection or irritation at infusion site (2 children, 2 adolescents/adults).

Adverse Events during the Omnipod 5 System Phase

Adverse Event Type	Children (6 to 13.9 years) (n=112)	Adolescents & Adults (14 to 70 years) (n=128)	Total (6 to 70 years) (N=240)
Hypoglycaemia ‡	1	0	1
Severe Hypoglycaemia §	1	2	3
DKA	1	0	1
Hyperglycaemia ¶	1	2	3
Prolonged Hyperglycaemia **	13	5	18
Other	8	8	16

Results reported as number of events.

‡ Hypoglycaemia resulting in a serious adverse event, but otherwise not meeting the definition of severe hypoglycaemia.

§ Required the assistance of another person.

¶ Hyperglycaemia requiring evaluation, treatment or guidance from the intervention site, or hyperglycaemia resulting in a serious adverse event

** Meter blood glucose measuring ≥ 16.7 mmol/L (≥ 300 mg/dL) and ketones > 1.0 mmol/L.

Glycaemic Results at Target Glucose Settings in Pivotal Study

The tables below provide information on the glycaemic results at various self-selected Target Glucose settings during the 3-month Omnipod 5 System phase of the pivotal study. Of the customisable Glucose targets, the most selected was 6.1 mmol/L (110 mg/dL)

Overall (24 hours) Glycaemic Results at Target Glucose Settings in Children (6 to 13.9 years) from Pivotal Study

Characteristic	6.1 mmol/L, 110 mg/dL Target Glucose (n=98)	6.7 mmol/L, 120 mg/dL Target Glucose (n=74)	7.2 mmol/L, 130 mg/dL Target Glucose (n=47)	7.8 mmol/L, 140 mg/dL Target Glucose (n=12)	8.3 mmol/L, 150 mg/dL Target Glucose* (n=9)
Avg % time 3.9–10 mmol/L, 70–180 mg/dL (std dev)	68.4% (9.1%)	67.5% (9.7%)	64.2% (14.3%)	59.2% (16.9%)	53.3% (18.2%)
Avg sensor glucose, mmol/L, mg/dL (std dev)	8.8, 159 (0.9, 17)	9.1, 163 (0.9, 16)	9.4, 169 (1.3, 24)	9.9, 178 (1.3, 24)	10.2, 183.6 (1.3, 23.9)
% Time in glucose range					
Median % < 3 mmol/L, < 54 mg/dL (Q1, Q3)	0.22% (0.06, 0.49)	0.18% (0.05, 0.33)	0.09% (0.00, 0.21)	0.04% (0.00, 0.34)	0.00% (0.00, 0.00)
Median % < 3.9 mmol/L, < 70 mg/dL (Q1, Q3)	1.51% (0.76, 2.38)	1.16% (0.58, 1.94)	0.71% (0.26, 1.63)	0.59% (0.05, 1.52)	0.12% (0.00, 0.21)
Avg % > 10 mmol/L, > 180 mg/dL (std dev)	29.7% (9.6%)	31.1% (10.0%)	34.5% (14.8%)	39.9% (16.6%)	46.4% (18%)
Avg % ≥ 13.9 mmol/L, ≥ 250 mg/dL (std dev)	9.7% (5.8%)	10.0% (6.3%)	11.8% (9.0%)	14.6% (11.1%)	13.3% (11.9%)
Cumulative number of person-days	6,289	2,716	941	99	73

Overall (24 hours) Glycaemic Results at Target Glucose Settings in Adolescents and Adults (14 to 70 years) from Pivotal Study

Characteristic	6.1 mmol/L, 110 mg/dL Target Glucose (n=121)	6.7 mmol/L, 120 mg/dL Target Glucose (n=54)	7.2 mmol/L, 130 mg/dL Target Glucose* (n=9)
Avg % time 3.9–10 mmol/L, 70–180 mg/dL (std dev)	75.6% (9.9%)	73.4% (12.1%)	63.6% (25.9%)
Avg sensor glucose, mmol/L, mg/dL (std dev)	8.4, 151 (0.8, 15)	8.7, 156 (1.0, 18)	9.6, 172 (1.8, 33)
% Time in glucose range			
Median % < 3 mmol/L, < 54 mg/dL (Q1, Q3)	0.16% (0.05, 0.26)	0.11% (0.00, 0.33)	0.00% (0.00, 0.00)
Median % < 3.9 mmol/L, < 70 mg/dL (Q1, Q3)	0.99% (0.47, 1.67)	0.91% (0.31, 1.68)	0.26% (0.05, 0.63)
Avg % > 10 mmol/L, > 180 mg/dL (std dev)	23.1% (10.2%)	25.4% (12.3%)	35.9% (26.1%)
Avg % ≥ 13.9 mmol/L, ≥ 250 mg/dL (std dev)	5.1% (4.6%)	5.8% (6.4%)	9.6% (12.3%)
Cumulative number of person-days	9,278	1,827	178

**Results for the 7.8 mmol/L (140 mg/dL) and 8.3 mmol/L (150 mg/dL) (with the Activity feature OFF) Target Glucose settings in adults are not shown due to too few participants selecting them (n≤2).*

Omnipod 5 System Pre-Pivotal Glycaemic Results at Target Glucose Settings

Glycaemic Results at Target Glucose Settings in Pre-Pivotal Study

The goal of the pre-pivotal study of the Omnipod 5 System was to assess the safety and efficacy of the system. This single-arm, multicentre, prospective study enrolled 18 children (6 to 13.9 years) and 18 adults (14 to 70 years) with type 1 diabetes. A 2-week standard therapy phase (usual insulin regimen) was followed by 2 weeks of Omnipod 5 System use in Automated Mode with a Dexcom G6 Sensor. The 2-week Omnipod 5 phase included 3 days of required use at each of the Target Glucose settings of 7.2 mmol/L (130 mg/dL), 7.8 mmol/L (140 mg/dL), and 8.3 mmol/L (150 mg/dL) for a total of 9 days, followed by 5 days of free choice of Target Glucose ranging from 6.1–8.3 mmol/L (110–150 mg/dL).

Overall (24 hours) Glycaemic Results at Target Glucose Settings in Children (6 to 13.9 years) from Pre-Pivotal Study

Characteristic	6.1 mmol/L, 110 mg/dL Target Glucose (n=11)	6.7 mmol/L, 120 mg/dL Target Glucose (n=3)	7.2 mmol/L, 130 mg/dL Target Glucose (n=18) ^a	7.8 mmol/L, 140 mg/dL Target Glucose (n=18)	8.3 mmol/L, 150 mg/dL Target Glucose (n=18) ^b
Avg % time 3.9–10 mmol/L, 70–180 mg/dL (std dev)	71.2% (10.2%)	66.8% (12.9%)	61.5% (7.7%)	64.8% (11.6%)	53.5% (11.0%)
Avg sensor glucose, mmol/L, mg/dL (std dev)	8.6, 155.2 (1.0, 18.2)	9.4, 170 (0.9, 16)	9.7, 174.1 (0.6, 11.4)	9.6, 172.7 (1.0, 17.2)	10.2, 182.9 (0.9, 15.3)
% Time in glucose range					
Median % < 3 mmol/L, < 54 mg/dL (Q1, Q3)	0.1% (0.0, 0.4)	0.2% (0.0, 0.3)	0.0% (0.0, 0.3)	0.0% (0.0, 0.0)	0.0% (0.0, 0.1)
Median % < 3.9 mmol/L, < 70 mg/dL (Q1, Q3)	0.9% (0.4, 2.8)	0.3% (0.2, 2.2)	0.5% (0.1, 0.8)	0.1% (0.0, 0.5)	0.5% (0.0, 0.8)
Avg % > 10 mmol/L, > 180 mg/dL (std dev)	27.1% (11.4%)	32.3% (11.9%)	37.7% (7.9)	34.6% (12.1%)	45.9% (11.0%)
Avg % ≥ 13.9 mmol/L, ≥ 250 mg/dL (std dev)	6.8% (6.3%)	14.4% (6.2%)	13.2% (5.8%)	10.6% (7.3%)	12.8% (8.1%)
Cumulative number of person-days	47.7	8.7	73.3	56.3	61.5

^aAll participants initiated the system at the 7.2 mmol/L (130 mg/dL) Target Glucose for 3 days.

^bThe glycaemic results at the 8.3 mmol/L (150 mg/dL) Target Glucose setting include times with the Activity feature ON and OFF, meaning the results recorded during this time may include those when participants felt their insulin needs were reduced.

Overall (24 hours) Glycaemic Results at Target Glucose Settings in Adolescents and Adults (14 to 70 years) from Pre-Pivotal Study

Characteristic	6.1 mmol/L, 110 mg/dL Target Glucose (n=12)	6.7 mmol/L, 120 mg/dL Target Glucose (n=7)	7.2 mmol/L, 130 mg/dL Target Glucose (n=18) ^a	7.8 mmol/L, 140 mg/dL Target Glucose (n=18)	8.3 mmol/L, 150 mg/dL Target Glucose (n=18) ^b
Avg % time 3.9–10 mmol/L, 70–180 mg/dL (std dev)	72.5% (9.4%)	70.9% (11.3%)	75.1% (11.6%)	67.6% (9.2%)	63.7% (7.8%)
Avg sensor glucose, mmol/L, mg/dL (std dev)	8.5, 153.8 (0.8, 14.8)	8.9, 159.7 (0.6, 11)	8.5, 153.8 (0.8, 14.9)	9.2, 165.4 (0.6, 11.5)	9.4, 169.8 (0.5, 9.4)
% Time in glucose range					
Median % < 3 mmol/L, < 54 mg/dL (Q1, Q3)	0.0% (0.0, 0.0)	0.0% (0.0, 0.0)	0.0% (0.0, 0.2)	0.0% (0.0, 0.1)	0.0% (0.0, 0.2)
Median % < 3.9 mmol/L, < 70 mg/dL (Q1, Q3)	0.5% (0.0, 1.4)	0.4% (0.0, 0.6)	0.9% (0.4, 1.2)	0.1% (0.0, 0.6)	0.2% (0.0, 0.9)
Avg % > 10 mmol/L, > 180 mg/dL (std dev)	26.4% (10.0%)	28.7% (11.2%)	23.4% (11.4%)	31.7% (9.2%)	35.7% (7.9%)
Avg % ≥ 13.9 mmol/L, ≥ 250 mg/dL (std dev)	4.1% (3.4%)	5.2% (5.5%)	5.0% (4.6%)	5.1% (4.5%)	6.0% (4.8%)
Cumulative number of person-days	41.1	28	58.8	58.4	60.3

^aAll participants initiated the system at the 7.2 mmol/L (130 mg/dL) Target Glucose for 3 days.

^bThe glycaemic results at the 8.3 mmol/L (150 mg/dL) Target Glucose setting include times with the Activity feature ON and OFF, meaning the results recorded during this time may include those when participants felt their insulin needs were reduced.

CGM-Informed SmartBolus Calculator Clinical Study in Children, Adolescents and Adults

A study was conducted on 25 participants with type 1 diabetes aged 6–70 years to assess the Omnipod 5 Sensor-informed SmartBolus Calculator. During Phase 1, participants used the Omnipod 5 system in Manual Mode for the first 7 days without a connected Sensor (standard SmartBolus Calculator). In Phase 2, participants used the Omnipod 5 system in Manual Mode with a connected Sensor (CGM-informed SmartBolus Calculator) for 7 days. Boluses were calculated using stored pump settings plus user-estimated meal size and/or either a manually entered glucose value (standard SmartBolus Calculator) or an imported current sensor glucose value and trend (CGM-informed SmartBolus Calculator). Both versions of the SmartBolus Calculator considered Insulin on Board (IOB) in the bolus calculations. The CGM-informed calculator automatically increased or decreased the suggested bolus amount based on the sensor glucose trend. The primary analysis of the study was to compare the per cent of time spent < 3.9 mmol/L (< 70 mg/dL) and > 10 mmol/L (> 180 mg/dL) for the 4 hours after any bolus as measured by Sensor between the two study phases. The results indicate that the use of the Sensor-informed SmartBolus Calculator was associated with less time in hypoglycaemia within 4 hours of bolusing. The study was conducted using a Dexcom G6 Sensor.

Comparison of Glycaemic Measures from Phase 1 (Standard SmartBolus Calculator) and Phase 2 (CGM-Informed SmartBolus Calculator) for the 4 hours After any Bolus (N=25)

Per cent time in glucose range as measured by Sensor	Standard Smart-Bolus Calculator	CGM-Informed SmartBolus Calculator	Difference
3.9–10 mmol/L (70–180 mg/dL)	65.1% (15.4)	63.8% (15.7)	-1.3%
< 3.9 mmol/L (< 70 mg/dL)	2.8% (2.7)	2.1% (2.0)	-0.6%*
< 3 mmol/L (< 54 mg/dL)	0.5% (1.0)	0.3% (0.7)	-0.2%
> 10 mmol/L (>180 mg/dL)	32.1% (15.7)	34.0% (16.0)	1.9%
≥13.9 mmol/L (≥ 250 mg/dL)	8.2% (6.9)	9.7% (10.3)	1.4%
≥ 16.7 mmol/L (≥ 300 mg/dL)	2.0% (2.6)	2.6% (3.7)	0.6%

Data is presented as average (standard deviation). Significant differences ($p < 0.05$) are highlighted with an asterisk.

25.2 Studies in Very Young Children with Type 1 Diabetes

Omnipod 5 Clinical Study in Very Young Children

The goal of this study was to assess the safety and effectiveness of the Omnipod 5 System in children with type 1 diabetes aged 2 to 5.9 years. This single-arm, multicentre, prospective study enrolled 80 children.

A 2-week standard therapy phase (usual insulin regimen) was followed by 3 months of Omnipod 5 System use in Automated Mode with a Dexcom G6 Sensor. The primary analysis consisted of A1C and sensor glucose time in range (3.9–10 mmol/L, 70–180 mg/dL) results.

The primary safety endpoints included the incidence of severe hypoglycaemia and diabetic ketoacidosis (DKA). An analysis of the secondary endpoints and additional metrics was also performed. An analysis of the primary, secondary and safety results are presented in the tables below.

Of the 80 participants enrolled, 100% completed the trial. The study population consisted of children diagnosed with type 1 diabetes based on the investigator's clinical judgement. All participants were required to have an A1C < 10.0% at screening. Participants had to be living with a parent or legal guardian. No participants with the following conditions were enrolled:

History of severe hypoglycaemia or DKA in the past 6 months

- Sickle cell disease, adrenal insufficiency, abnormal kidney function (eGFR < 45), haemophilia or any other bleeding disorders, untreated thyroid disease.
- Plans to receive a blood transfusion during study.
- Taking oral or injectable steroids or diabetes medications other than metformin and insulin.

The safety and effectiveness of the Omnipod 5 System in users with the conditions above is unknown. Please note that the study exclusion list above is condensed and does not include every exclusion criterion. The trial was registered at clinicaltrials.gov, a national database of clinical trials in the United States, with ID number NCT04476472. Full details of the study criteria can be found there.

Demographics

Baseline characteristics, including demographics of the participants at the start of the 3-month Omnipod 5 treatment phase, are provided in the table below.

Baseline Characteristics at Omnipod 5 Treatment Phase Start

Characteristic	
n	80
Age (years) ± std dev	4.7 ± 1.0
Duration of diabetes (years)	2.3 ± 1.1
A1C§	7.4% ± 1.0%
Daily insulin dose (U/kg) ¥	0.69 ± 0.18
Body mass index (BMI) (kg/m ²)	16.7 ± 1.5
Female sex	34 (42.5%)
Previous¶ or current continuous glucose monitor (CGM) use	78 (97.5%)
Previous¶ or current pump use	68 (85.0%)
Using multiple daily injections as standard therapy method	12 (15.0%)
Race/Ethnicity‡	
White	67 (83.8%)
Hispanic or Latino	5 (6.3%)
Black or African American	4 (5.0%)
Black or African American, White	3 (3.8%)
Asian	3 (3.8%)
Asian, White	2 (2.5%)
Hispanic or Latino	1 (1.3%)
Not Hispanic or Latino	1 (1.3%)
Other (Dominican)	1 (1.3%)
Hispanic or Latino	1 (1.3%)

Plus-minus values are average ± standard deviation; results reported with a number in brackets afterwards represent number of participants (% of participants).

§ A1C determined from laboratory assessment.

¥ Baseline Total Daily Insulin dose was determined from data collected during the standard therapy phase.

¶ Previous use is defined as having used the device for any duration in the past.

‡ Race and ethnicity were reported by the participants. Groups are not mutually exclusive.

Glycaemic Results

The tables below include information on the primary and secondary glycaemic results from the standard therapy phase compared with the 3-month Omnipod 5 System treatment phase. The primary results of the study included change in average A1C% and % time in range (3.9–10 mmol/L, 70–180 mg/dL). Participants experienced improvements in A1C and overall time in range after 3 months of Omnipod 5 System use. This result was achieved with a reduction of time > 10 mmol/L (> 180 mg/dL) as well as a reduction in median time < 3.9 mmol/L (<70 mg/dL)

Some limitations to the study include: 1) single-arm design with no control group, which could lead to an over-estimate of glycaemic improvement; 2) the standard therapy phase was shorter than the Omnipod 5 System phase.

Glycaemic Results Overall (24 hours)

Characteristic	Standard Therapy	Omnipod 5	Change
Avg A1C% (std dev)	7.4% (1.0%)	6.9% (0.7%)	-0.55%*
Avg % time 3.9–10 mmol/L, 70–180 mg/dL (std dev)	57.2% (15.3%)	68.1% (9.0%)	10.9%*
Avg sensor glucose, mmol/L, mg/dL, (std dev)	9.5, 171.1 (1.7, 30.5)	8.7, 157.4 (0.9, 16.8)	-0.7, -13.7*
Avg standard deviation of sensor glucose, mmol/L, mg/dL (std dev)	3.6, 64.9 (0.7, 13.4)	3.3, 59.6 (0.6, 10.3)	-0.3, -5.3*
Avg coefficient of variation of sensor glucose, % (std dev)	38.1% (5.5%)	37.7% (4.0%)	-0.4%
% Time in Glucose Range			
Median % < 3 mmol/L, < 54 mg/dL (Q1, Q3)	0.24% (0.05, 0.84)	0.26% (0.16, 0.60)	0.06%
Median % < 3.9 mmol/L, < 70 mg/dL (Q1, Q3)	2.19 (0.89, 4.68)	1.94 (1.18, 3.43)	-0.27%*
Avg % > 10 mmol/L, > 180 mg/dL (std dev)	39.4% (16.7%)	29.5% (9.8%)	-9.9%*
Avg % ≥ 13.9 mmol/L, ≥ 250 mg/dL (std dev)	14.8% (12.1%)	9.2% (5.6%)	-5.6%*
Avg % ≥ 16.7 mmol/L, ≥ 300 mg/dL (std dev)	6.0% (7.3%)	3.2% (2.8%)	-2.7%*

Most of the primary and secondary results are presented as averages (avg) with standard deviation (std dev) values in brackets. Time in range < 3.9 mmol/L (< 70 mg/dL) and < 3 mmol/L (< 54 mg/dL) is reported as medians with interquartile ranges in brackets (Q1, Q3). The median is the middle number in an ascending list of numbers and the interquartile range represents the middle 50% of values.

*Change between the standard therapy phase and the Omnipod 5 System phase was statistically significant.

25 Overview of Omnipod 5 System Pivotal Clinical Study

Glycaemic Results Overnight (00:00 to 06:00)

Characteristic	Standard Therapy	Omnipod 5	Change
Avg % time 3.9–10 mmol/L, 70–180 mg/dL (std dev)	58.2% (18.7%)	81.0% (10.0%)	22.8%*
Avg sensor glucose, mmol/L, mg/dL, (std dev)	9.3, 168.1 (1.8, 33.3)	7.8, 140.7 (0.9, 16.4)	-1.5, -27.4*
Avg standard deviation of sensor glucose, mmol/L, mg/dL (std dev)	3.2, 58.0 (0.8, 14.0)	2.5, 45.5 (0.6, 10.8)	-0.7, -12.5*
Avg coefficient of variation of sensor glucose, % (std dev)	34.7% (6.6%)	32.1% (5.2%)	-2.6%*
% Time in Glucose Range			
Median % < 3 mmol/L, < 54 mg/dL (Q1, Q3)	0.00% (0.00, 0.97)	0.18% (0.06, 0.53)	0.00%
Median % < 3.9 mmol/L, < 70 mg/dL (Q1, Q3)	1.66% (0.40, 4.21)	1.58% (0.65, 2.89)	-0.44%*
Avg % > 10 mmol/L, > 180 mg/dL (std dev)	38.4% (20.1%)	16.9% (10.3%)	-21.5%*
Avg % ≥ 13.9 mmol/L, ≥ 250 mg/dL (std dev)	13.0% (13.2%)	3.9% (3.9%)	-9.1%*
Avg % ≥ 16.7 mmol/L, ≥ 300 mg/dL (std dev)	4.3% (6.7%)	1.2% (1.6%)	-3.1%*

*Change between the standard-therapy phase and the Omnipod 5 System phase was statistically significant.

Change in A1C Analysed by Baseline A1C

The table below provides information on the average change in A1C% from baseline to the end of the 3-month Omnipod 5 System treatment phase analysed by baseline A1C%. Participants experienced a reduction in A1C after 3 months of Omnipod 5 System use regardless of baseline A1C < 8% or ≥ 8% category.

Subgroup Analysis of Change in Average A1C(%) by Baseline A1C(%)

	Baseline A1C <8% (n=55)			Baseline A1C ≥8% (n=25)		
	Baseline	Omnipod 5	Change	Baseline	Omnipod 5	Change
A1C% (std dev)‡	6.9% (0.6%)	6.6% (0.6%)	-0.31%*	8.5% (0.5%)	7.5 (0.4%)	-1.06%*

*Change between the standard therapy phase and the Omnipod 5 System phase was statistically significant.

‡Average A1C values are reported with standard deviation values in brackets.

Glycaemic Results by Baseline Treatment

The table below provides information on the average glycaemic results at baseline (or during the standard therapy phase) and the 3-month Omnipod 5 System treatment phase analysed by baseline treatment (standard therapy). Standard therapy consisted of multiple daily insulin injections (MDI) or insulin pump use. Time in range (3.9–10 mmol/L, 70–180 mg/dL) and A1C were improved after 3 months of Omnipod 5 System use regardless of baseline treatment type. Time < 3.9 mmol/L (< 70 mg/dL) improved in participants on an insulin pump at baseline and remained low in those on MDI at baseline.

Subgroup Analysis of Average Glycaemic Results by Baseline Treatment

Characteristic	MDI (n=12)		Insulin Pump (n=68)	
	Standard Therapy	Omnipod 5	Standard Therapy	Omnipod 5
% Time in range 3.9–10 mmol/L (70–180 mg/dL)	48%	62%*	59%	69%*
% Time < 3.9 mmol/L (< 70 mg/dL);	1.45%	1.48%	2.44%	2.00%*
A1C%	8.4%	7.5%*	7.3%	6.8%*

*Change between the standard therapy phase and the Omnipod 5 System phase was statistically significant.

‡ Values presented for % Time < 3.9 mmol/L (< 70 mg/dL) are medians; the remaining values in the table are averages.

Insulin Requirements

The table below provides information on the average insulin requirements during the standard therapy phase and the 3-month Omnipod 5 System phase. Total Daily Insulin requirements remained unchanged except for an increase in total daily basal insulin.

Characteristic	Standard Therapy	Omnipod 5	Change
Avg Total Daily Insulin (U) (std dev)	13.7 (4.4)	14.1 (4.0)	0.4
Avg Total Daily Insulin, U/kg (std dev)	0.69 (0.18)	0.71 (0.15)	0.02
Avg total daily basal insulin, U/kg, (std dev)	0.28 (0.12)	0.32 (0.10)	0.04*
Avg total daily bolus insulin, U/kg, (std dev)	0.41 (0.15)	0.39 (0.10)	-0.02 (0.10)

*Change between the standard-therapy phase and the Omnipod 5 System phase was statistically significant.

Body Mass Index Results

The table below provides information on the average body mass index (BMI) and BMI z-score during the standard therapy phase and the 3-month Omnipod 5 System phase. BMI and BMI z-score did not change between the two phases.

Characteristic	Standard Therapy	Omnipod 5	Change
BMI, kg/m ² (std dev)	16.7 (1.5)	16.7 (1.4)	0.1
BMI z-score (std dev)	0.74 (0.95)	0.76 (0.89)	0.05

Omnipod 5 System Use

The median (Q1, Q3) % of time study participants used the Omnipod 5 System in Automated Mode was 97.8% (95.8, 98.5).

Adverse Events

The table below provides a full list of the adverse events that occurred during the 3-month Omnipod 5 System treatment phase. Other related, but non-glycaemic adverse events included skin irritation (n=2), cellulitis (n=1) and ketosis not meeting the DKA definition (n=2).u

Adverse Events during the Omnipod 5 System Phase

Adverse Event Type	Omnipod 5
Hypoglycaemia ‡	0
Severe Hypoglycaemia §	0
DKA	0
Hyperglycaemia ¶	4
Prolonged Hyperglycaemia **	20
Other	5

Results reported as number of events.

‡Hypoglycaemia resulting in a serious adverse event, but otherwise not meeting the definition of severe hypoglycaemia.

§Required the assistance of another person.

¶Hyperglycaemia requiring evaluation, treatment or guidance from the intervention site, or hyperglycaemia resulting in a serious adverse event.

***Meter blood glucose measuring ≥ 16.7 mmol/L (≥ 300 mg/dL) and ketones > 1.0 mmol/L*

Glycaemic Results at Target Glucose Settings

The tables below provide information on the glycaemic results at various self-selected Target Glucose settings during the 3-month Omnipod 5 System phase of the pivotal study. The most commonly selected Target Glucose values were 6.1 mmol/L (110 mg/dL) and 6.7 mmol/L (120 mg/dL), which were used 33% and 42% of the time, respectively.

Overall (24 hours) Glycaemic Results at Target Glucose Settings

Characteristic	6.1 mmol/L (110 mg/dL) Target Glucose (n=47)	6.7 mmol/L (120 mg/dL) Target Glucose (n=61)	7.2 mmol/L (130 mg/dL) Target Glucose (n=47)	7.8 mmol/L (140 mg/dL) Target Glucose (n=20)	8.3 mmol/L (150 mg/dL) Target Glucose* (n=16)
Avg % time 3.9–10 mmol/L, 70–180 mg/dL, (std dev)	69.3% (9.5%)	68.3% (11.3%)	67.3% (14.6%)	63.0% (11.9%)	65.0% (15.0%)
Avg sensor glucose, mmol/L, mg/dL, (std dev)	8.5, 153 (1, 18)	8.7, 157 (1.2, 21)	8.9, 161 (1.4, 25)	9.4, 169 (1, 18)	9.4, 169 (1.1, 20)
% Time in glucose range					
Median % < 3 mmol/L, < 54 mg/dL, (Q1, Q3)	0.3% (0.2, 0.7)	0.2% (0.1, 0.5)	0.2% (0.05, 0.7)	0.2% (0.03, 0.5)	0.06% (0.0, 0.2)
Median % < 3.9 mmol/L, < 70 mg/dL, (Q1, Q3)	2.4% (1.5, 3.9)	1.6% (1.1, 2.7)	1.4% (0.6, 2.9)	1.4% (0.4, 2.7)	0.8% (0.1, 2.0)
Avg % > 10 mmol/L, > 180 mg/dL (std dev)	27.6% (10.5%)	29.3% (12.1%)	30.4% (15.4%)	35.4% (12.2%)	33.9% (15.0%)
Avg % ≥ 13.9 mmol/L, ≥ 250 mg/dL (std dev)	7.7% (5.9%)	8.9% (6.2%)	10.6% (9.4%)	12.6% (6.2%)	11.4% (7.2%)
Cumulative number of person-days	2438.4	3083.5	1066.6	404.0	237.0

*Glycaemic measures reported at the 8.3 mmol/L (150 mg/dL) Target Glucose setting only included those with the Activity feature turned OFF.

CGM-Informed SmartBolus Calculator Clinical Study in Very Young Children

A study was conducted on 5 participants with type 1 diabetes aged 2–5.9 years to assess the Omnipod 5 CGM-informed SmartBolus Calculator in Manual Mode. During Phase 1, participants used the Omnipod 5 system in Manual Mode for the first 7 days without a connected Sensor (standard SmartBolus Calculator). In Phase 2, participants used the Omnipod 5 system in Manual Mode with a connected Sensor (CGM-informed SmartBolus Calculator) for 7 days. Boluses were calculated using stored pump settings plus user-estimated meal size and/or either a manually entered glucose value (standard SmartBolus Calculator) or an imported current sensor glucose value and trend (CGM-informed SmartBolus Calculator). Both versions of the SmartBolus Calculator considered Insulin on Board (IOB) in the bolus calculations. The CGM-informed calculator automatically increased or decreased the suggested bolus amount based on the sensor glucose trend. The primary analysis of the study was to compare the percentage of time spent < 3.9 mmol/L (< 70 mg/dL) and > 10 mmol/L (> 180 mg/dL) for the 4 hours after any bolus as measured by the Sensor between the two study phases. The results showed that the CGM-informed SmartBolus Calculator provided similar glycaemic results to the standard SmartBolus Calculator when used in Manual Mode.

Comparison of Glycaemic Measures from Phase 1 (Standard SmartBolus Calculator) and Phase 2 (CGM-Informed SmartBolus Calculator) for the 4 hours After any Bolus (N=5)

Per cent time in glucose range as measured by the Sensor	Standard SmartBolus Calculator	CGM-Informed SmartBolus Calculator	Difference
3.9–10 mmol/L (70–180 mg/dL)	59.6% (7.1%)	62.8% (15.5%)	3.15%
< 3.9 mmol/L (< 70 mg/dL)	5.16% (4.99%)	4.03% (3.28%)	-1.13%
< 3 mmol/L (< 54 mg/dL)	1.47% (1.88%)	0.81% (0.91%)	-0.66%
> 10 mmol/L (> 180 mg/dL)	35.2% (10.3%)	33.2% (18.5%)	-2.03%
≥ 13.9 mmol/L (≥ 250 mg/dL)	9.4% (5.7%)	7.9% (6.4%)	-1.55%
≥ 16.7 mmol/L (≥ 300 mg/dL)	2.33% (2.69%)	1.99% (2.05%)	-0.34%

Data is presented as average (standard deviation).

This page intentionally left blank.

ADDITIONAL INFORMATION

- 26** Frequently Asked Questions and Troubleshooting
.....
Appendix



This page intentionally left blank.

CHAPTER 26

Frequently Asked Questions and Troubleshooting

Contents

26.1 Omnipod 5 Pump FAQs	360
Pod Issues	360
Finding Out How Much Insulin Was Delivered	362
Controller Issues	363
Omnipod 5 App Issues.....	363
26.2 SmartBolus Calculator FAQs	365
26.3 Sensor FAQs	366
Dexcom G6.....	366
FreeStyle Libre 2 Plus.....	368
High Glucose Issues.....	369
Low Glucose Issues	371
26.4 Automated Mode FAQs	372
26.5 Pod Communication Issues – “Try Again”	374
No Pod Communication.....	374
What should you do?	374
Additional Troubleshooting Options.....	374
Reboot the Omnipod 5 App.....	374
Discard Pod and Activate a New Pod	375
Error when sending insulin instructions to the Pod	375
Error when cancelling a bolus.....	376
Error when activating a Pod.....	376
Error when deactivating a Pod.....	376
26.6 About Keeping Your Omnipod 5 Controller Nearby	377
26.7 Device Complaints	378
26.8 Factory Mode and Boot Mode	379
Factory Mode.....	379
Boot Mode	379

26.1 Omnipod 5 Pump FAQs



The following topics have been frequently asked during the use of Omnipod 5, and the main causes and recommended actions are listed below.

Pod Issues

Issue	Possible Cause	What you can do
During Pod activation, did not hear the 2-beep confirmation after filling the Pod with insulin	Pod not filled with at least 85 units of insulin.	Make sure the Pod is filled with at least 85 units of insulin. If you have filled the Pod with at least 85 units and you still do not hear 2 beeps, you will need to discard the Pod and start a new one.
The adhesive around the Pod keeps lifting from the skin	It is important that the Pod stays on the body to ensure that the cannula stays under the skin to deliver insulin. If the area where you apply the Pod is not cleaned and dry, the adhesive may not stick well.	Make sure that the skin is cleaned and dry before applying the Pod. Avoid the use of moisturisers, oils, conditioners, sunscreen or insect repellent around the site. If there is a lot of body hair, you may need to clip or shave the area 24 hours prior to Pod change. Be sure to remove old adhesive residue from the skin. Insulet has produced a special tape called PodPals™ that can help keep the Pod on for longer.

Issue	Possible Cause	What you can do
Pod alarm sounding	Because the delivery of insulin is so critical to your health, it is important to know if the Pod stops working. The Pod may stop working for many reasons, for example, a blockage (occlusion) is detected, electrostatic discharge affects the circuit, or some interference is detected.	This continuous loud noise is intended to alert you to remove the Pod and replace it with a new one. You can try to deactivate the Pod with your Omnipod 5 App. Occasionally, the App will not be able to communicate with the Pod and you will have to discard the Pod. In this case, you will need to remove the Pod and disable the alarm switch. See page 179 for guidance.

Finding Out How Much Insulin Was Delivered

Issue	What you can do
<p>Where to see how much insulin is delivered while in Automated Mode</p>	<p>The Sensor Graph will show you the latest sensor glucose value received by the Pod and what mode of insulin delivery the system is in. (To see the graph, tap VIEW from the lower right part of the Home screen.) The graph will also show when your last boluses were delivered. You can see on the legend for the graph that insulin suspension is shown as the red bar, and maximum delivery during Automated Mode is shown as the orange bar.</p> <p>To know the exact amount of insulin delivered in Automated Mode, go to:</p> <p>Menu button () > History Detail > AUTO EVENTS</p> <p>This will show you the time, sensor glucose value and corresponding amount of insulin delivered at each 5-minute interval.</p>
<p>Where to find history of insulin deliveries</p>	<p>The Omnipod 5 App maintains the history for previous insulin deliveries. You can check here:</p> <p>Menu button () > History Detail > Summary.</p> <p>Scroll down and look for previous insulin deliveries. If you tap the entry, you will see how the calculations for the bolus were made if the SmartBolus Calculator was used.</p>

Controller Issues

Issue	Possible Cause	What you can do
Controller unable to power on or screen is unreadable	Device error	<p>Try restarting the Controller by holding down the Power button for 10 seconds. The Controller should restart and regain communication successfully. If the issue does not resolve, contact Insulet Customer Care.</p> <p>It is important to keep your settings recorded or written down in a safe place so that you can start a replacement system without delay. Insulet does not keep your insulin delivery settings.</p>
Screen turns black (times out) too soon	Screen Time-Out setting needs adjustment.	<p>You can change the screen setting so that the screen stays on for longer. On your Controller, go to: Menu button (≡) > Settings > General > Screen Time-Out.</p> <p>This can be set to 30 seconds, 1 minute or 2 minutes.</p>
Controller is charging slowly	Using a charging cable or adapter that did not come with the starter kit.	<p>Use ONLY the USB charging cable that you received in the box with your Controller. Avoid using alternative charging cables or other accessories, as they may damage the Controller or affect the way it charges in the future.</p>

Omnipod 5 App Issues

Warning: DO NOT apply a new Pod until you have deactivated and removed the old Pod. A Pod that is not deactivated properly can continue to deliver insulin as programmed, putting you at risk of over-delivery of insulin, which can lead to hypoglycaemia.

26 Frequently Asked Questions and Troubleshooting

Caution: DO NOT reset the Omnipod 5 App before checking with your healthcare provider. This will erase all of your settings, Adaptive Basal Rate and history, and require you to change your active Pod. Before resetting, make sure you have a current record of your settings and a new Pod with supplies to use when restarting the App.

Issue	Possible Cause	What you can do
<p>Received a “New Device Detected” message when signing into Omnipod 5 App</p>	<p>You are currently signed into another Controller with your Omnipod ID.</p>	<p>Note: If you are wearing an active Pod when signing into a new device, your current Pod will still be delivering insulin, but you will not be able to manage it on the new device.</p> <ol style="list-style-type: none"> 1. Remove the current Pod in order to stop receiving insulin. 2. After removing the current Pod, you will need to go through the setup process again, including pairing a new Pod and re-entering information about your Sensor.
<p>Opening the Omnipod 5 App restarts the setup process</p>	<p>You cleared App data for the Omnipod 5 App. This causes you to lose all your settings and insulin history.</p>	<p>If you clear data for the Omnipod 5 App, your current Pod will still be delivering insulin, but you won't be able to manage it with your Omnipod 5 App.</p> <ol style="list-style-type: none"> 1. Remove the current Pod in order to stop receiving insulin. 2. After removing the current Pod, you will need to go through the setup process again, including pairing a new Pod and re-entering information about your Sensor. <p>Tip: If you use Dexcom G6, you can get your Transmitter serial number (SN) from the Dexcom G6 App. If you do not have a record of your settings, contact your healthcare provider for assistance.</p> <p>Note: It may take the Sensor and Pod up to 20 minutes to connect.</p>

26.2 SmartBolus Calculator FAQs

Issue	Possible Cause	What you can do
<p>With carbs entered and sensor glucose value available, the SmartBolus Calculator recommends no bolus or 0 insulin.</p>	<p>You have already received a lot of insulin (your IOB is high) and your sensor glucose trend is falling.</p>	<p>You can remove the sensor glucose value so that the calculator only suggests a bolus amount for the carbs entered.</p> <p>Alternatively, you can decide on a different amount and enter this directly into the Total Bolus field at the bottom of the screen.</p> <p>Check your Calculations screen before you deliver a bolus to see how the calculator determines the suggested bolus. Always confirm the bolus amount before you deliver it to make sure the system delivers what you want.</p>

Issue	What you can do
<p>I'm having a second serving of an item at a meal. How should I handle delivering a bolus?</p>	<p>After meals, it is common for glucose to rise.</p> <p>If you have already bolused for carbohydrates and entered a sensor glucose value or blood glucose reading at the start of a meal, you can just enter carbohydrates for the second serving. The SmartBolus Calculator will suggest a bolus amount for the carbohydrates only.</p>

26 Frequently Asked Questions and Troubleshooting

<p>I typically deliver the bolus following the meal as it is difficult to predict how many carbs my child will eat. What is the best way to use the SmartBolus Calculator in this case?</p>	<p>It is difficult, especially for young children, to predict how much will be eaten at each meal. In this case, you may choose to use the SmartBolus Calculator to deliver the correction bolus by tapping USE SENSOR or entering the blood glucose reading to deliver some insulin prior to the meal. After you are comfortable, you can enter the carbohydrates separately into the SmartBolus Calculator to deliver the full meal bolus.</p>
---	--

26.3 Sensor FAQs

Dexcom G6

Dexcom G6 Issue	Possible Cause	What you can do
Activated a Pod and cannot see sensor glucose values in the Omnipod 5 App	Problem with the Sensor or Transmitter.	Check your Dexcom G6 App and if you do not see sensor glucose values, then follow instructions there.
	Transmitter serial number (SN) is not entered into the Omnipod 5 App.	<ol style="list-style-type: none">1. Go to: Menu button (☰) > Manage Sensor.2. Make sure the SN is entered and entered correctly. If you have just connected, it can take up to 20 minutes for values to appear in the Omnipod 5 App.
	You are using the Dexcom G6 receiver.	<ol style="list-style-type: none">1. Use the Dexcom G6 App on your smartphone. The Omnipod 5 System is not compatible with the Dexcom G6 receiver.2. Then, turn off the Dexcom G6 receiver.

Dexcom G6 Issue	Possible Cause	What you can do
<p>Sensor glucose values no longer show up in the Omnipod 5 App. Instead, there are dashes. The Dexcom G6 App does not show a problem.</p>	<p>The most likely reason this could happen is an interruption in communication between the Transmitter and the Pod.</p>	<p>To minimise the risk of interruption, make sure your Sensor, Transmitter and Pod are worn on the same side of the body. Wireless communications do not travel well through the body. For example, if your Sensor is worn on the abdomen and the Pod is on the back of the arm, the signal may be interrupted. Try to keep the Pod and Sensor on the same side of the body to maximise your time in Automated Mode.</p> <p>You can also try deleting the Transmitter serial number (SN) and re-entering it.</p> <ul style="list-style-type: none"> ➤ Go to: Menu button (☰) > Manage Sensor <p>This resets the communication between the Transmitter and the Pod.</p>
<p>Sensor glucose values on the Dexcom G6 App look different from those on the Omnipod 5 App.</p>	<p>The Dexcom G6 App receives sensor glucose values directly from the Sensor. The Omnipod 5 App receives sensor glucose values from the Pod. Occasionally, there is a slight delay before the value is updated on the Omnipod 5 App.</p>	<p>The difference should be minor. To bring the value up to date, bring the Controller close to the Pod.</p>

FreeStyle Libre 2 Plus

FreeStyle Libre 2 Plus Sensor Issue	Possible Cause	What you can do
<p>Activated a Pod and cannot see FreeStyle Libre 2 Plus sensor glucose values in the Omnipod 5 App.</p>	<p>Problem with the Sensor. FreeStyle Libre 2 Plus is not selected as the Sensor in the Omnipod 5 App.</p>	<p>Check your Omnipod 5 App. If you do not see sensor glucose values, then follow instructions there.</p> <ol style="list-style-type: none"> 1. Go to: Menu button () > Manage Sensor 2. Make sure FreeStyle Libre 2 Plus is selected. If you have just connected, it can take up to 20 minutes for values to appear in the Omnipod 5 App.
<p>FreeStyle Libre 2 Plus sensor glucose values no longer show up in the Omnipod 5 App. Instead, there are dashes.</p>	<p>There may be an interruption in communication between the FreeStyle Libre 2 Plus Sensor and the Pod.</p>	<p>To minimise the risk of interruption, make sure your FreeStyle Libre 2 Plus Sensor and Pod are worn on the same side of the body. Wireless communications do not travel well through the body. For example, if your FreeStyle Libre 2 Plus Sensor is worn on the back of the right arm and the Pod is on the left side of the abdomen, the signal may be interrupted. Try to keep the Pod and Sensor on the same side of the body to maximise your time in Automated Mode.</p>

High Glucose Issues

Issue	Possible Cause	What you can do
<p>After using the system for a couple of weeks, sensor glucose values are running high after breakfast. The Insulin-to-Carb Ratio is the same.</p>	<p>One of the benefits of automated insulin delivery is the greater ability to stay closer to your Target Glucose overnight. What this often means is that, prior to breakfast, there is less insulin in your body compared with Manual Mode.</p>	<p>It is common to need changes to your Insulin-to-Carb Ratio, generally a lowering of the ratio to receive more insulin before meals (for example, lowering the carbohydrate value covered by 1 U of insulin). Another setting that you can change is Reverse Correction. When the toggle for this is ON (purple), it means the calculator will recommend less insulin when your sensor glucose value or blood glucose reading is below your Target Glucose.</p> <p>Discuss with your healthcare provider what settings are best for you. Your SmartBolus Calculator settings are available under: Menu button (☰) > Settings > Bolus.</p>

26 Frequently Asked Questions and Troubleshooting

Issue	Possible Cause	What you can do
<p>After using the system in Automated Mode for a few weeks, sensor glucose values have been running high.</p>	<p>Your Target Glucose may need to be adjusted. In Automated Mode, Target Glucose is the main setting that you can control to adjust automated insulin delivery.</p>	<p>Check your Target Glucose here:</p> <p>Menu button (≡) > Settings > Bolus</p> <p>The Target Glucose can be set between 6.1–8.3 mmol/L (110–150 mg/dL). If you're running high, you can try reducing the Target Glucose around the period that you're running higher than desired.</p>
	<p>Other SmartBolus Calculator settings may need to be adjusted.</p>	<p>Think about your SmartBolus Calculator settings: In particular, your Insulin-to-Carb Ratio, Correction Factor and Target Glucose might need to be adjusted. For example, if these high periods are after lunch, you might need more insulin around lunchtime to reduce the likelihood of running high in the afternoon.</p> <p>Changing your Basal Programmes or Max Basal setting will not make a difference for the Automated Mode function. This only works for Manual Mode.</p> <p>Discuss with your healthcare provider what settings are best for you.</p>

Issue	Possible Cause	What you can do
Sensor glucose values have been running high over several days.	Although the system is able to automate insulin delivery, your body's insulin needs can change daily. This means that every day with diabetes is different.	Think about diet, exercise, Pod insertion site, and change in your body's needs and how they are affecting your glucose. The system will adapt with every new Pod to give you just the right amount of insulin to get you to the Target Glucose. As the system detects higher insulin needs, it will adapt to adjust insulin dosing accordingly.

Low Glucose Issues

Issue	Possible Cause	What you can do
Sensor glucose values are running low in the late evening; needing hypoglycaemia treatment before going to bed.	Your Target Glucose may need to be adjusted for the period to avoid the low.	Check your Target Glucose here: Menu button (≡) > Settings > Bolus
	If lows are happening soon after the dinner bolus, you might need adjustment of your SmartBolus Calculator settings to receive less insulin for the dinner bolus. Another option is to check how long it has been since the last bolus.	Discuss with your healthcare provider what settings are best for you. Your SmartBolus Calculator settings are available here: Menu button (≡) > Settings > Bolus

26 Frequently Asked Questions and Troubleshooting

<p>Following afternoon exercise, sensor glucose values are getting low.</p>	<p>During exercise, your body is often prone to low glucose.</p>	<p>To reduce the risk of this low, you can use the Activity feature. With this feature, the system delivers less insulin and also drives insulin delivery to a target of 8.3 mmol/L (150 mg/dL). It is recommended that you turn this setting ON at least 30-60 minutes before exercise.</p> <p>Exercise with diabetes requires trial and error. Keep a record of activity, carbohydrates consumed and insulin delivery to work out the best method for you. Your healthcare provider can help provide different ways to confidently manage your diabetes with exercise.</p>
---	--	--

26.4 Automated Mode FAQs

Issue	Possible Cause	What you can do
<p>Activated a Pod and unable to switch to Automated Mode (with Dexcom G6).</p>	<p>Your Transmitter serial number (SN) is not entered into the Omnipod 5 App.</p>	<p>Go to: Menu button () > Manage Sensor.</p> <p>Tip: Always check that the Sensor information entered into the Omnipod 5 App is the same as the number on the Sensor you are wearing.</p>
<p>Activated a Pod and unable to switch to Automated Mode (with FreeStyle Libre 2 Plus)</p>	<p>Your Sensor is not the one that you started and paired with the Omnipod 5 App on your Controller.</p>	<p>Activate a new FreeStyle Libre 2 Plus Sensor and pair it with the Pod with the Omnipod 5 App on your Controller.</p>

<p>Screen shows Automated Mode: Limited</p>	<p>Interruption in communication between the Transmitter and the Pod.</p>	<p>To minimise the risk of interruption, make sure your Pod and Sensor are worn on the same side of the body. Wireless communications do not travel well through the body. For example, if your Sensor is worn on the abdomen and the Pod is on the back of the arm, the signal may be interrupted.</p>
	<p>Problem with the Sensor</p>	<p>There may be a temporary communication issue between your Pod and the Sensor.</p> <p>If you use Dexcom G6, check your Dexcom G6 App to see if there are sensor glucose values present or if the cause of the loss of communication is related to the Sensor.</p> <p>If you use FreeStyle Libre 2 Plus, check your Notifications and Manage Sensor screens in your Omnipod 5 App for any details about a problem with your Sensor.</p> <p>You may decide to switch to Manual Mode or wait for a sensor glucose value to be received.</p>
	<p>Automated Mode may have reached the limits of insulin delivery, either the maximum or the minimum.</p>	<p>Follow the instructions on the screen to check your glucose. After 5 minutes in Manual Mode and you are confident that your Pod and Sensor are working well, you can switch back to Automated Mode. See page 318.</p>

26.5 Pod Communication Issues – “Try Again”

Warning: DO NOT apply a new Pod until you have deactivated and removed the old Pod. A Pod that is not deactivated properly can continue to deliver insulin as programmed, putting you at risk of over-delivery of insulin, which can lead to hypoglycaemia.

Warning: ALWAYS contact Customer Care if your Omnipod 5 System Controller is damaged and not working properly. If a Controller replacement is needed, ALWAYS consult with your healthcare provider to get instructions on using other backup insulin delivery methods, like insulin injections. Make sure to check your glucose frequently.

No Pod Communication

There may be times while wearing an active Pod when the Pod and the Omnipod 5 App are unable to communicate. You will see the message “No Pod Communication” in the Pod Info tab when this occurs. Your Dashboard will also show “Searching for Pod”.

If your App is attempting to send an instruction to your Pod (e.g., a bolus), an error will appear on your screen and the App will beep every 10 seconds until the message is acknowledged.

What should you do?

- Bring your Controller or compatible smartphone within five feet of your active Pod to try to restore connection.
- Ensure that no other Pods that have been previously discarded are within 6 m (20 ft) of your Controller or compatible smartphone.
- If there is an error displayed in your App, tap Try Again (or Check Status) and follow the on-screen instructions to resolve the issue.
- Toggle Bluetooth on and off, if using a compatible smartphone, and remove other devices that may be connected to Bluetooth.

If the above steps do not resolve the communication issue, attempt the options below.

Additional Troubleshooting Options

Reboot the Omnipod 5 App

Controller: Hold down the Power button for approximately 10 seconds, then tap “Power Off”. Let your device turn off completely, then turn back on. This process may last approximately 20 seconds.

Compatible Smartphone: Restart your compatible smartphone. When the phone restarts, open the Omnipod 5 App and tap Try Again (or Check Status) and communication should be restored.

Discard Pod and Activate a New Pod

This option should only be used when the above troubleshooting steps have not resolved the communication issue in your Omnipod 5 App.

- Select DISCARD POD
 - Note:** Discarding the Pod will end communication between the Pod and your Omnipod 5 App. The Pod is not deactivated and can still deliver insulin
- Remove the Pod and ensure it is outside of the communication range of the App (approximately 6 m or 20 ft)
 - If you previously connected your discarded Pod to your Sensor, you will need to move it out of range of the Sensor (approximately 9 m or 30 ft) to allow the new Pod and Sensor to establish communication
- Activate and apply your new Pod.

Tip: When there is a communication issue, the Omnipod 5 App offers you options to help you resolve it. It is in your best interest to leave any options to DISCARD or DEACTIVATE POD as the last choice after trying the other option(s).

Error when sending insulin instructions to the Pod

A communication error may occur when the Omnipod 5 App attempts to send insulin delivery instructions to the Pod. If a communication error occurs when the Omnipod 5 App attempts to send an insulin delivery instruction, the Omnipod 5 App offers you different options.

If the Omnipod 5 App has sent the Pod the instruction and hasn't received confirmation that it was carried out, the Omnipod 5 App offers these options:

- **CHECK STATUS:** Move to a new location, then select this option to recheck for confirmation that the instruction was carried out.
- **DEACTIVATE POD:** This should not be your first choice. When you select this option, you can follow the instructions for replacing your Pod.

If the Omnipod 5 App has not sent the Pod the instruction, the Omnipod 5 App tells you to move to a new location, and tap TRY AGAIN to reattempt communication. After you tap TRY AGAIN, if the next communication attempt fails, the Omnipod 5 App offers these options:

- **CANCEL:** Select this option to cancel sending the instruction. In this case, the Pod continues with its prior insulin delivery mode. You can try to send the instruction later.

26 Frequently Asked Questions and Troubleshooting

- **TRY AGAIN:** Move to a new location, then select this option to tell the Omnipod 5 App to reattempt to send the instruction to the Pod.
- **DEACTIVATE POD:** This should not be your first choice. When you select this option, you can follow the instructions for replacing your Pod.

Error when cancelling a bolus

If you are trying to cancel a bolus when a communication error occurs, the following options become available:

- **CANCEL:** Select this option to stop attempting to cancel the bolus. The Pod continues to deliver the bolus.
Note: If the 'cancel bolus' instruction has already been sent, this CANCEL option is not available.
- **TRY AGAIN:** Move to a new location, then select this option to tell the Omnipod 5 App to continue attempting to communicate with the Pod.
- **DEACTIVATE POD:** This should not be your first choice. When you select this option, you can follow the instructions for replacing your Pod.

If the "cancel bolus" instruction has already been sent from the Omnipod 5 App when a communication error occurs, the Omnipod 5 App offers these options:

- **CHECK STATUS:** Select this option to attempt to re-establish communication with the Pod and obtain the current status of the "cancel bolus" command
- **DEACTIVATE POD:** This should not be your first choice. Select this option to deactivate the Pod when CHECK STATUS is unsuccessful.

Error when activating a Pod

If a communication error occurs during Pod activation, the following options become available:

- **DISCARD POD:** This should not be your first choice. Select this option to stop attempting to use this Pod.
- **TRY AGAIN:** Select this option to attempt to re-establish communication.

Error when deactivating a Pod

If a communication error occurs during Pod deactivation, the following options become available:

- **DISCARD POD:** Select this option if the TRY AGAIN option has not resolved the problem. This will tell your Omnipod 5 System to unpair

from that Pod. The Omnipod 5 App instructs you to remove your Pod and tap CONTINUE.

- **TRY AGAIN:** Select this option to attempt to re-establish communication.

Note: After selecting the discard option, you can prevent future alarms from the discarded Pod by following the instructions in “13.9 Silencing Unresolved Alarms” on page 179.

Note: If there is an unconfirmed bolus when you discard a Pod, the Omnipod 5 System does not know how much of the bolus was delivered. Therefore, the Omnipod 5 System temporarily disables the SmartBolus Calculator for a period equal to your Duration of Insulin Action setting. If you tap the Bolus button while the SmartBolus Calculator is disabled, the Omnipod 5 App displays a message that says “SmartBolus Calculator temporarily disabled”. You can deliver a Manual bolus when the SmartBolus Calculator is disabled.

26.6 About Keeping Your Omnipod 5 Controller Nearby

You will use your Controller to activate a new Pod every 2–3 days. After you activate a Pod, you will start receiving insulin based on your active Basal Programme in Manual Mode, whether or not your Controller is nearby. You will need to access the App, however, to resolve any alerts or alarms that may originate from your Pod, to deliver a bolus, or check the status of your System and glucose.

After you have either entered an active Dexcom G6 Transmitter serial number (SN) into the Omnipod 5 App or started a FreeStyle Libre 2 Plus Sensor with the Omnipod 5 App, you can switch from Manual Mode to Automated Mode. In Automated Mode, the Pod will directly receive sensor glucose values wirelessly and automate insulin delivery depending on your needs.

The System is designed to continue delivering insulin in the absence of your Controller, so you will not be alerted that the Pod and display device are out of range of one another if you choose to leave your Controller behind.

Although your Omnipod 5 System does not require the Controller to be nearby to continue your insulin delivery in Manual Mode or Automated Mode, the Controller provides you with important information about recent insulin delivery, alerts and alarms that come from your Pod, and allows you to deliver a bolus.

Caution: AVOID leaving your Controller in a place that would prevent you from hearing alarms and notifications from your Omnipod 5 App. Delivery of insulin in Manual Mode or Automated Mode continues as programmed if you move away from your Controller.

26.7 Device Complaints

If a serious incident has occurred during the use of this device or as a result of its use, please report it to the manufacturer and/or its authorised representative and to your national authority.

Contact details for the manufacturer can be found in the inside front cover of this document (see “Contacts and Important Information” on page i). The contacts of national competent authorities (Vigilance Contact Points) and further information can be found on the following European Commission website: https://ec.europa.eu/health/md_sector/contact_en

If you have a problem with your System, contact Customer Care. You may be asked to share device data.

To share device data:

1. Ensure a working Wi-Fi connection.
2. Go to: Menu button () > About
3. Tap Send files to Customer Care.
4. Enter the PIN provided by Customer Care.

If you see an exclamation mark (!) icon, alert your Customer Care representative. Navigate to the Home Screen to clear the (!) icon. If the icon persists, restart your Controller.

If this occurs: Data upload is pending.

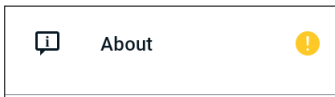

If this occurs: Data upload is full.

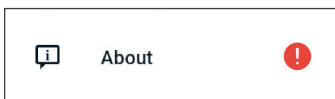

26.8 Factory Mode and Boot Mode

Factory Mode

Factory Mode may appear when you are holding down the Volume DOWN button while pressing the Power Button. This typically happens when powering up the Controller.

Since the touch screen will not work in this mode, you will need to navigate through the options using the Volume buttons. Use the Power Button to select the highlighted option.

In the Factory Mode menu, the options are “Version” and “Reboot”. Your selection is highlighted with a blue background and yellow-coloured text.

1. Press the Volume Down button to move the highlighted bar to the “Reboot” option.
2. Press the Power button to select the “Reboot” option.

Note: If you select the Version option by mistake, press the Volume Down button until Back is highlighted on the bottom right corner of the screen. Press the Power button to return to the Factory Mode screen.

3. The Controller will reboot and start normally after selecting Reboot.

Boot Mode

Boot Mode may appear when you are holding down the Volume UP button while pressing the Power Button. This typically happens when powering up the Controller.

Since the touch screen will not work in this mode, you will need to navigate through the options using the Volume buttons. Use the Power Button to select the highlighted option.

In the Boot Mode menu, the options are “Recovery Mode”, “Fastboot Mode”, and “Normal Mode”. Your selection is highlighted with <<== pointing to the option.

1. Press the Volume Up Button on the Controller until the <<== is pointing to the Normal Boot option.
2. Press the Volume Down Button on the Controller to make the selection.
3. The Controller will reboot and start normally after selecting Normal.

Note: If you select “Recovery” or “Fastboot” by mistake, you will need to do a Hard Reset. To Hard Reset the Controller, press and hold down the Power button for 7 to 10 seconds until the screen turns off and restarts.

This page intentionally left blank.

Appendix

Summary of Settings and Options

The options for the various Omnipod 5 Automated Insulin Delivery System settings are:

Time format	12-hour or 24-hour clock
Time zone	GMT-11:00 to GMT+13:00.
Daylight Saving Time	ON or OFF. Default based on date and time zone.
Date format	DD/MM/YYYY
Screen time-out	30, 60, 120 seconds. Default is 30 seconds.
PIN	4 digits from 0 to 9.
Dexcom G6 Transmitter serial number (SN)	6 characters.
Maximum Basal Rate	Select one value between 0.05–30 U/hr in 0.05 U/hr increments. Default is 3.00 U/hr.
Basal rate	Units/hr. Range: 0 U/hr to Maximum Basal Rate in 0.05 U/hr increments.
Basal Programmes	Maximum of 12.
Basal rate segments	24 per Basal Programme.
Activity feature	Range: 1 to 24 hrs In increments of 1 hour
Temp Basal	%, units/hr, or OFF. Default is OFF. Duration: 30 min to 12 hrs in 30-min increments.
Temp Basal (set to %)	Range: 100% decrease (0 U/hr) to 95% increase from current basal rate in 5% increments. Cannot exceed the Maximum Basal Rate.
Temp Basal (set to U/hr)	Range: 0 U/hr to Maximum Basal Rate in 0.05 U/hr increments.
Temp Basal Presets	Maximum of 12.
Glucose Goal Range (for blood glucose history)	Lower and upper limits: 3.9 to 11.1 mmol/L (70 to 200 mg/dL) in 0.1 mmol/L (1 mg/dL) increments.
BG Reminder	ON or OFF. Default is OFF. Maximum of 4 active at one time. A Reminder can occur between 30 min and 4 hrs after a bolus is started. Set in 30-minute increments.
Target Glucose value	Maximum of 8 segments; 6.1 to 8.3 mmol/L (110 to 150 mg/dL) in 0.55 mmol/L (10 mg/dL) increments.

Correct Above threshold	Maximum of 8 segments; Target Glucose to 11.1 mmol/L (200 mg/dL) in 0.1 mmol/L (1 mg/dL) increments.
Minimum Glucose for Calculations	2.8 to 3.9 mmol/L (50 to 70 mg/dL) in 0.1 mmol/L (1 mg/dL) increments Default is 3.9 mmol/L (70 mg/dL).
Insulin-to-Carb (IC) Ratio	Maximum of 8 segments; 1 to 150 g carb/U in 0.1 g carb/U increments.
Correction (sensitivity) Factor	Maximum of 8 segments; 0.1–22.2 mmol/L (1–400 mg/dL) in 0.1 mmol/L (1 mg/dL) increments. Default is 2.8 mmol/L (50 mg/dL).
Reverse Correction	ON or OFF. Default is ON.
Duration of Insulin Action	2 to 6 hours in 30-minute increments. Default is 4 hours.
Bolus size	Range: 0.05–30 U in 0.05 U increments.
Extended Bolus	%, Units, or OFF. Default is OFF. 30 minutes to 8 hours in 30-minute increments.
Pause insulin	30 minutes to 2 hours.
Low Pod Insulin advisory	10 to 50 units in 1-unit increments. Default is 10.0 U.
Pod expiry notification	1 to 24 hours in 1-hour increments. Default is 4 hours.
Pod Shut-Off timer	OFF, or 1 to 24 hours in 1-hour increments. Default is OFF.
History screen display	Rolling 90-day period.
Language	Multiple languages.

Pod Specifications

Size: 3.9 cm wide x 5.2 cm long x 1.45 cm high (1.53 in x 2.05 in x 0.57 in)

Weight (without insulin): 26 g (0.92 oz)

Operating temperature range: Pod operating environment of 5°C to 40°C (41°F to 104°F).

Start-up temperature: above 10°C (50°F)

Storage temperature range: 0°C to 30°C (32°F to 86°F)

Warm-up time (0°C to 20°C [32°F to 68°F]): 7 minutes

Cooldown time: No time is required for cooldown from maximum storage temperature (30°C [86°F]) to operating temperature.

Reservoir volume (deliverable): 200 units

Cannula insertion depth: 4 to 7 mm (0.16–0.28 in)

Depth of insulin infusion: ≥ 4 mm (0.16 in)

IP (Ingress Protection) rating for moisture and dust: IP28 (protected from touch by fingers and objects 12.5 mm (0.5 in) or larger; protected from water to a depth of up to 7.6 m (25 ft) for up to 60 minutes)

Insulin concentration: U-100

Alarm type: Audible. Output: ≥ 45 db(A) at 1 m

Sterilising agent: sterilised using ethylene oxide

Operating relative humidity range: 20 to 85%, non-condensing

Storage relative humidity range: 20 to 85%, non-condensing

Operating atmospheric pressure: 700 hPa to 1,060 hPa

Storage atmospheric pressure: 700 hPa to 1,060 hPa

Non-pyrogenic: Fluid pathway only

Type BF applied part: Protection from electrical shock

Maximum infusion pressure: 35 psi

Maximum volume infused under single fault conditions: 0.05 U

Flow Capability:

Prime rate: 0.05 units per second.

Basal: Programmable by the user in 0.05 U increments up to 30.0 U per hour

Bolus Rate: 1.5 units per minute. Dose range from 0.05 to 30.0 units

Delivery accuracy (tested per IEC 60601-2-24):

Basal: $\pm 5\%$ at rates ≥ 0.05 U/hr

Bolus: $\pm 5\%$ for amounts ≥ 1.0 unit

± 0.05 units for amounts < 1.0 unit

Note: You should consider bolus dose accuracy when setting a bolus dose. When using the lowest bolus dose allowable (0.05 units), the actual bolus delivered may be as low as 0.00 units or as high as 0.10 units.

Accuracy test results: The following graph shows the flow accuracy of the Pod against given time periods. The measurements were made using a Pod with a basal rate of 0.5 $\mu\text{L}/\text{h}$ (which delivers 0.05 U/h of U-100 insulin) at a high operating temperature. The overall mean percentage flow error was 1.40%.

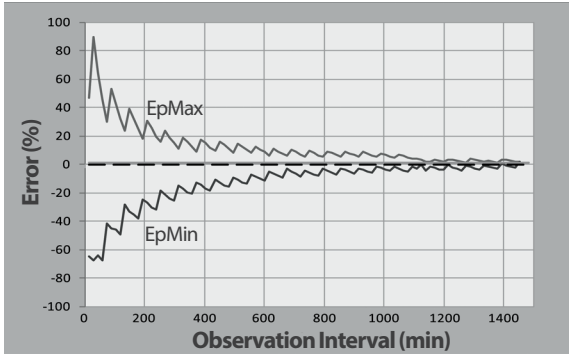

Controller Specifications

Size: 143.92 mm high x 67.57 mm wide x 12.33 mm deep (5.67 in x 2.66 in x 0.49 in)

Weight: 165 g (5.82 oz)

Screen active area: 56.16 mm wide x 120.58 mm high (2.21 in x 4.75 in)

Operating temperature range: 5°C to 40°C (41°F to 104°F)

Storage temperature range: 0°C to 30°C (32°F to 86°F)

Operating relative humidity range: 20% to 90%, non-condensing

Storage relative humidity range: 20% to 90%, non-condensing

Operating atmospheric pressure: 700 hPa to 1,060 hPa

Storage atmospheric pressure: 700 hPa to 1,060 hPa

Communication distance: The Controller and Pod should be:

- At start-up: Adjacent and touching, with the Pod either in or out of the tray, to ensure proper communication during priming.
- During normal operation: Within 1.5 m (5 ft) of each other. Depending on the location, the communication distance may handle separations of up to 15 m (50 ft) away.

Alarm type: Audible. Output: ≥ 45 db(A) at 1 m

IP (Ingress Protection) rating for moisture and dust: IP22 (protected from touch by fingers and objects 12.5 mm (5 in) or larger; not well-protected from water - avoid liquid)

Notification type: Audible and vibratory

Battery: Rechargeable Li-ion battery, 3.8 V, 2,800 mAh

Battery Operational Life: Full charge covers approximately 36 hours with typical use.

Controller Service Life: Approximately 2 years (based on 300–500 charge cycles) with typical use

Shelf Life (Starter Kit): 18 months

Battery charger operating line voltage: 100 to 240 VAC, 50/60 Hz

Only use the Noetic-approved power adapter (Insulet PN PT-000428) with the Controller.

Dexcom Specifications

For information about the Dexcom operating specifications, see the *Dexcom G6 CGM System Instructions for Use*.

FreeStyle Libre 2 Plus Sensor Specifications

For information about the FreeStyle Libre 2 Plus Sensor operating specifications, see the *FreeStyle Libre 2 Plus User's Manual*.

Theory of Operation for Physiologic Closed Loop Control System

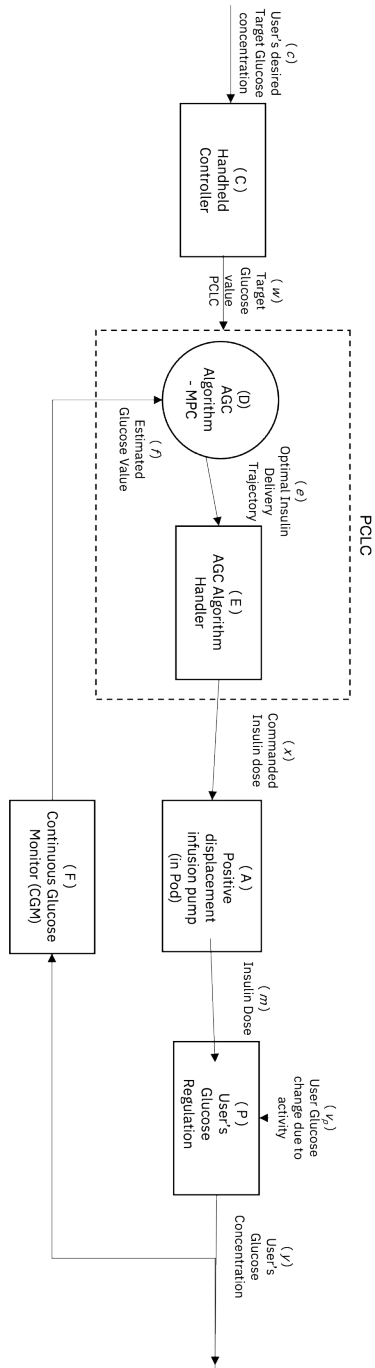

Protection from Over-Infusion or Under-Infusion

The Pod software monitors the infusion rate. If an error that would result in over-infusion or under-infusion is detected and cannot be corrected, insulin delivery stops, and an alarm sounds.

Blockage (occlusion) detection

Warning: ALWAYS monitor your glucose and follow your healthcare provider's treatment guidelines when you stop receiving insulin due to a blockage (occlusion). Not taking action promptly could result in under-delivery of insulin, which can lead to hyperglycaemia or diabetic ketoacidosis (DKA) (see “ Blockage Detected” on page 158).

Caution: ALWAYS check your glucose frequently when you use very low basal rates. Checking your glucose frequently can alert you to the presence of a blockage (occlusion). Blockages can result in hyperglycaemia.

A blockage (occlusion) is an interruption in insulin delivery from the Pod. If the Omnipod 5 System detects a blockage, it sounds a Hazard Alarm and prompts you to deactivate and change your Pod.

A blockage Hazard Alarm sounds when an average of 3 units to 5 units of missed insulin occurs. The following table depicts blockage detection for three different situations when using U-100 insulin. For example, if the Pod's cannula becomes blocked when delivering a 5 U bolus, 35 minutes may pass before the Pod sounds a Hazard Alarm.

	Time between blockage and Pod alarm	
	Typical time	Maximum time
5.00 U bolus	33 minutes	35 minutes
1.00 U/hr basal	3.0 hr	5.5 hr
0.05 U/hr basal	51 hr	80 hr (Pod expiry)

If a blockage spontaneously clears up, a volume of insulin could be released. That volume would not exceed the volume of the programmed insulin intended for delivery.

If your Omnipod 5 System detects a potential blockage to your insulin delivery, it will set a blockage alarm to sound. If a blockage alarm is set to sound while an immediate bolus is in progress, the alarm is delayed until completion of the bolus.

Performance Characteristics

The Omnipod 5 insulin pump delivers insulin in two ways: basal insulin delivery (continuous) and bolus insulin delivery. The following accuracy data were collected on both types of delivery in laboratory studies performed by Insulet.

The Summary of Safety and Clinical Performance (SSCP) is available at www.omnipod.com/sscp. The SSCP is also available in the European Database on Medical Devices (EUDAMED) website (<https://ec.europa.eu/tools/eudamed>), where it is linked to the Basic UDI-DI. The Basic UDI-DI for Omnipod 5 is 038508AIDSH.

Delivery performance characterisation

Basal Delivery: In order to assess basal delivery accuracy, 12 Pods were tested by delivering at low, medium and high basal rates (0.05, 1.00 and 30.0 U/hr). Water was used as a substitute for insulin. The water was pumped into a container on a scale, and the weight of the liquid at various time points was used to assess pumping accuracy.

The following tables report the typical basal performance (median) observed, along with the lowest and highest results observed for the low, medium and high basal rate settings for all pumps tested, with no warm-up period. For each time period, the tables show the volume of insulin requested in the first row and the volume that was delivered as measured by the scale in the second row.

Low Basal Rate Delivery Performance (0.05 U/hr)

Basal Duration (Number of units requested)	1 hour (0.05 U)	6 hours (0.30 U)	12 hours (0.60 U)
Amount Delivered	0.049 U	0.30 U	0.59 U
[min, max]	[0.00, 0.12]	[0.13, 0.57]	[0.34, 0.99]

Medium Basal Rate Delivery Performance (1.00 U/hr)

Basal Duration (Number of units requested)	1 hour (1.00 U)	6 hours (6.00 U)	12 hours (12.00 U)
Amount Delivered	0.99 U	5.97 U	11.88 U
[min, max]	[0.65, 1.55]	[5.06, 6.87]	[10.53, 13.26]

High Basal Rate Delivery Performance (30.00 U/hr)		
Basal Duration (Number of units requested)	1 hour (30.00 U)	6 hours (180.00 U)
Amount Delivered	29.82 U	179.33 U
[min, max]	[28.85, 31.39]	[177.49, 181.15]

Note: A measurement at the 12-hour period with a 30.0 U/hr basal rate is not applicable to the Omnipod 5 System as the reservoir will empty at approximately 6 $\frac{2}{3}$ hours at this rate.

Bolus Delivery: In order to assess bolus delivery accuracy, 12 Pods were tested by delivering a minimum, intermediate and maximum bolus amount (0.05, 5.00 and 30.0 Units). Water was used as a substitute for insulin. The water was pumped into a container on a scale and the weight of the liquid delivered was used to assess pumping accuracy.

The following table summarises the typical bolus performance observed for the requested minimum-, intermediate- and maximum-size bolus for all pumps tested. For each individual target bolus size, the number of boluses observed is shown along with the average (mean), minimum, and maximum units delivered as measured by a scale.

Individual Bolus Accuracy Performance	Target Bolus Size (Units)	Mean Bolus Size (Units)	Min Bolus Size (Units)	Max Bolus Size (Units)
Min Bolus Delivery Performance (n= 5,987 boluses)	0.05 U	0.050 U	0.00 U	0.119 U
Intermediate Bolus Delivery Performance (n= 300 boluses)	5.00 U	5.01 U	4.49 U	5.37 U
Max Bolus Delivery Performance (n= 72 boluses)	30.00 U	30.05 U	29.56 U	30.62 U

Appendix

The tables that follow show, for each requested bolus size, the range of amount of insulin that was observed to have been delivered compared with the requested amount. Each table provides the number and percentage of delivered bolus sizes observed within the specified range.

Amount of Insulin Delivery for a Minimum (0.05 U) Bolus Request

Amount (Units)	< 0.0125	0.0125–0.0375	0.0375–0.045	0.045–0.0475	0.0475–0.0525
(% of settings)	(< 25%)	(25–75%)	(75–90%)	(90–95%)	(95–105%)
Number and percentage of boluses within range	61/5,987 (1%)	639/5,987 (10.7%)	1,284/5,987 (21.4%)	504/5,987 (8.4%)	1,100/5,987 (18.4%)
Amount (Units)	0.0525–0.055	0.055–0.0625	0.0625–0.0875	0.0875–0.125	> 0.125
(% of settings)	(105–110%)	(110–125%)	(125–175%)	(175–250%)	(> 250%)
Number and percentage of boluses within range	504/5,987 (8.4%)	1,192/5,987 (19.9%)	582/5,987 (9.7%)	121/5,987 (2%)	0/5,987 (0%)

Amount of Insulin Delivery for an Intermediate (5.00 U) Bolus Request



























Amount (Units)	< 1.25	1.25–3.75	3.75–4.50	4.50–4.75	4.75–5.25
(% of settings)	(< 25%)	(25–75%)	(75–90%)	(90–95%)	(95–105%)
Number and percentage of boluses within range	0/300 (0%)	0/300 (0%)	1/300 (0.3%)	4/300 (1.3%)	287/300 (95.7%)
Amount (Units)					
	5.25–5.50	5.50–6.25	6.25–8.75	8.75–12.50	> 12.50
(% of settings)	(105–110%)	(110–125%)	(125–175%)	(175–250%)	(> 250%)
Number and percentage of boluses within range	8/300 (2.7%)	0/300 (0%)	0/300 (0%)	0/300 (0%)	0/300 (0%)















Amount of Insulin Delivery for a Maximum (30.0 U) Bolus Request







Amount (Units)	< 7.5	7.5–22.5	22.5–27.0	27.0–28.5	28.5–31.5
(% of settings)	(< 25%)	(25–75%)	(75–90%)	(90–95%)	(95–105%)
Number and percentage of boluses within range	0/72 (0%)	0/72 (0%)	0/72 (0%)	0/72 (0%)	72/72 (100%)
Amount (Units)					
	31.5–33.0	33.0–37.5	37.5–52.5	52.5–75.0	> 75.0
(% of settings)	(105–110%)	(110–125%)	(125–175%)	(175–250%)	(> 250%)
Number and percentage of boluses within range	0/72 (0%)	0/72 (0%)	0/72 (0%)	0/72 (0%)	0/72 (0%)

Omnipod 5 System Label Symbols

The following symbols appear on the Omnipod 5 System or its packaging:

Symbol	Meaning	Symbol	Meaning
	Do not re-use		MR unsafe
	Refer to instruction manual/booklet		Do not use if package is damaged and consult instructions for use
	Sterilized using ethylene oxide		Type BF applied part
	Date of manufacture		Manufacturer
	Country of Manufacture – United States of America		Country of Manufacture – Malaysia
	Country of Manufacture – China		Compatible with
	Batch code		Keep dry
	Use-by date		Temperature limit
	Catalogue number		Humidity limitation
	Serial number		Atmospheric pressure limitation
	UK Conformity Assessed		Australian Regulatory Compliance Mark
	Marking of conformity		Importer
IP28	Protects persons against access to hazardous parts with fingers and protects against solid foreign object ingress of diameter 12.5 mm or greater; Submersible: Waterproof to 7.6 meters (25 feet) for up to 60 minutes	IP22	Protects persons against access to hazardous parts with fingers and protects against solid foreign object ingress of diameter 12.5 mm or greater; avoid liquid
	Non-pyrogenic fluid path		Medical device

Symbol	Meaning	Symbol	Meaning
	Discard electrical and electronic equipment separately from standard waste.	RoHS	RoHS compliant
	Single sterile barrier system		Single patient multiple use
	Compatible with U-100 Insulin Only		Consult instructions for use or consult electronic instructions for use
FCC ID:	Federal Communication Commission Identifier with number	Rx ONLY	Caution: Federal law restricts this device to sale by or on the order of a physician
IC:	Complies with ISED Canada Radio Standards Specifications	HVIN:	Hardware version identification number
	Switzerland Authorized Representative		Authorized representative in the European Community/ European Union
	(France) The Triman indicates that the product must be sorted or returned to a collection point.		Intertek Authorized Product Certification Mark
	(France) This product must be separated from conventional perforating DASTRI for recycling.		(France) This pictogram means that the product contains a piercing object.
	(France) Electronic perforating waste must be stored in the secure DASTRI purple box. These purple boxes are distributed free of charge in pharmacies.		(France) All pharmacies distribute and collect DASTRI needle boxes free of charge from self-treatment patients.
	(France) Packaging intended for recycling		(France) the puncture waste must be placed in a DASTRI needle box. These needle boxes are distributed by pharmacies.

Symbol	Meaning	Symbol	Meaning
	Charging cable		Charging adapter
	Fill Syringe and Needle Assembly		Pod
	Controller skin		Omnipod 5 Controller

Omnipod 5 System Notice Concerning Interference

Caution: DO NOT make changes or modifications to any component of the Omnipod 5 System that has not been authorised by Insulet Corporation. Unauthorised tampering with the System can revoke your right to operate it.

The Omnipod 5 Automated Insulin Delivery System is designed to comply with Part 15 of the Federal Communications Commission (FCC) Rules. Operation is subject to the following two conditions:

1. These devices may not cause harmful interference.
2. These devices must accept any interference received, including interference that may cause undesirable operation.

This equipment has been tested and found to comply with the limits for a Class B digital device, pursuant to Part 15 of the FCC Rules. These limits are designed to provide reasonable protection against harmful interference in a residential installation. This equipment generates, uses, and can radiate radio frequency energy, and, if not installed and used in accordance with the instructions, may cause harmful interference to radio communications. However, there is no guarantee that interference will not occur in a particular installation.

If the equipment does cause harmful interference to radio and television reception, the user is encouraged to try to correct the interference by one of the following measures:

- Move or relocate the Omnipod 5 System.
- Increase the separation between the Omnipod 5 System and the other device that is emitting or receiving interference.
- Consult the dealer or an experienced radio/TV technician for help.

Quality of Service

The Omnipod 5 System includes two wireless transmission pathways. Insulet defines the quality of service of the Omnipod 5 System for each of the two pathways:

Omnipod 5 App to Pod wireless communication definition

Successful transfer of commands, data and alarms between the Controller and Pod when in communication range (within 1.5 m (5 ft) during normal operation). The Omnipod 5 App informs the user when transfer of commands, data and alarms is unsuccessful. For Insulin Delivery commands, the system performance requirements state that communication between the Pod and the Controller occur within 8 seconds at a reliability rate of 95%. The Omnipod 5 App will inform the user when there are communication errors between the Pod and the Controller. When such an error occurs, the Omnipod 5 App will beep once every 10 seconds and the communication failure will continue to be indicated within the Omnipod 5 App until the communication error is resolved.

Pod to Sensor wireless communication definition

The percentage of Sensor glucose values successfully received by the Pod when the Sensor and Pod attempt to communicate every 5 minutes. The System performance requirements state that at least 80% of Sensor glucose values will be successfully received by the Pod when the Sensor is worn within the line of sight of the Pod. The System informs the user of missing Sensor glucose values in real time by the dashes on the home screen or by missed dots on the Sensor Graph.

For additional information on communication errors in the Omnipod 5 System, see Chapter 21. To maintain quality of service when other devices operating in the 2.4 GHz band are around, the Omnipod 5 System uses the coexistence features provided by Bluetooth® wireless technology.

Electromagnetic Compatibility

The information contained in this section (such as separation distances) is, in general, specifically written with regard to the Omnipod 5 System. The numbers provided will not guarantee faultless operation but should provide reasonable assurance of such. This information may not be applicable to other medical electrical equipment; older equipment may be particularly susceptible to interference.

General Notes

The Omnipod 5 System has been tested and found to have acceptable immunity to emissions from RFID and EAS systems.

The Omnipod 5 System is intended for use in the electromagnetic environment specified below. The customer or the user of the System should ensure that it is used in such an environment.

Medical electrical equipment requires special precautions regarding electromagnetic compatibility (EMC) and needs to be installed and put into service according to the EMC information provided in this document and the instructions for use. If the Omnipod 5 System fails due to electromagnetic disturbances, you may need to replace it.

Portable and mobile radio frequency (RF) communications equipment can affect the function of medical electrical equipment.

Caution: Use ONLY the USB charging cable and adapter that you received in the box with your Controller. AVOID using alternative charging cables or other accessories, as they may damage the Controller or affect the way it charges in the future. If you must use a different cable, use only cables less than or equal to 1.2 m (4 ft) in length.

Care should be taken if the Omnipod 5 System is used adjacent to other electrical equipment; if adjacent use is unavoidable, such as in work environments, the Omnipod 5 System should be observed to verify normal operation in this setting.

The Omnipod 5 System communicates by low-level RF energy. As with all RF receivers, the potential for disturbance exists, even with equipment that complies with FCC and CISPR emissions requirements.

The Omnipod 5 System communicates with the following characteristics:

Frequency: 2,400–2,480 GHz, digitally modulated, with an effective isotropic radiated power of 1.14 mW

The Omnipod 5 System complies with the immunity requirements of the general standard for electromagnetic compatibility, IEC 60601-1-2.

Caution: DO NOT use portable radio frequency (RF) communications equipment (including peripherals such as antenna cables and external antennas) closer than 30 cm (12 in) to any part of the Omnipod 5 System, as it may impact the communication between your Controller and your Pod.

Electromagnetic Emissions

This equipment is intended for use in the electromagnetic environment specified below. The user of this equipment should ensure that it is used in such an environment.

Emissions	Compliance according to	Electromagnetic environment
RF Emissions (CISPR11)	Group 1	The Pod, Controller and Transmitter emit low-level electromagnetic energy (RF) in order to communicate. Although unlikely, nearby electronic equipment may be affected.
CISPR B Emissions Classification	Class B	The System is suitable for use in all establishments, including domestic establishments.
Harmonic Emissions (IEC 61000-3-2)	Class A	
Voltage Fluctuations/ Flicker Emissions (IEC 61000-3-3)	$P_{st} \leq 1.0$ $P_{it} \leq 0.65$ $d_c \leq 3\%$ $d_{max} \leq 4\%$ $d_{(t)} \geq 200 \text{ ms}$ during a voltage change should be $\leq 3\%$	

Electromagnetic Immunity

The System is intended for use in the electromagnetic environment specified below. You should observe these requirements when using the System.

Immunity against	IEC 60601-1-2 test level	Compliance level (of this device)	Electromagnetic environment
ElectroStatic Discharge, ESD (IEC 61000-4-2)	contact discharge: ± 8 kV air discharge: ± 15 kV	± 8 kV ± 15 kV	If floors are covered with synthetic material, try to avoid electrostatic discharges.
Electrical Fast Transient/burst (IEC 61000-4-4)	± 2 kV power supply lines ± 2 kV Input DC Power Port ± 1 kV input/output lines	± 2 kV power supply lines ± 2 kV Input DC Power Port ± 1 kV input/output lines	Mains power quality should be that of a typical domestic, commercial or hospital environment.
Surge (IEC 61000-4-5)	± 1 kV differential mode ± 2 kV common mode	± 1 kV differential mode ± 2 kV common mode	Mains power quality should be that of a typical domestic, commercial or hospital environment.
Conducted Disturbances induced by RF fields (IEC 61000-4-6)	3 V 150 KHz–80 MHz 6 V in ISM and amateur radio bands between 150 KHz and 80 MHz	3 V 150 KHz–80 MHz 6 V in ISM and amateur radio bands between 150 KHz and 80 MHz	Suitable for most environments. Keep portable RF communications equipment at least 30 cm (12 in) away from the Omnipod 5 System.

Electromagnetic Immunity

<p>Voltage Dips, Short Interruptions, Voltage Variations on Power Supply input lines (IEC 61000-4-11)</p>	<p>70% UT (30% dip in UT) for 25/30 cycles</p> <p>0% UT (100% dip in UT) for 1 cycle at 0 degrees</p> <p>0% UT (100% dip in UT) for 0.5 cycles at 0, 45, 90, 135, 180, 225, 270 and 315 degrees</p> <p>0% UT (100% dip in UT) for 250/300 cycles</p>	<p>70% UT (30% dip in UT) for 25/30 cycles</p> <p>0% UT (100% dip in UT) for 1 cycle at 0 degrees</p> <p>0% UT (100% dip in UT) for 0.5 cycles at 0, 45, 90, 135, 180, 225, 270 and 315 degrees</p> <p>0% UT (100% dip in UT) for 250/300 cycles</p>	<p>Mains power quality should be that of a typical domestic, commercial or hospital environment. If the user requires continued operation during power mains interruption, it may be necessary to use an uninterruptible power supply or a battery.</p>
<p>Power frequency magnetic fields 50/60 Hz (IEC 61000-4-8)</p>	<p>30 A/m</p>	<p>400 A/m</p>	<p>Suitable for most environments. Magnetic field strengths in excess of 400 A/m would be unlikely except in close proximity to industrial magnetic devices.</p>
<p>Radiated RF (IEC 61000-4-3)</p>	<p>10 V/m at 80 MHz–2.7 GHz</p>	<p>10 V/m</p>	<p>Suitable for most environments. Keep portable RF communications equipment at least 30 cm (12 in) away from the Omnipod 5 System.</p>

Appendix

The table below lists the immunity levels at specific test frequencies for testing the effects of some wireless communication equipment. The frequencies and services listed in the table are representative examples in various locations where the System may be used.

Frequency (MHz)	Band a) (MHz)	Service a)	Modulation b)	Maximum power (W)	Distance (m)	IMMUNITY TEST LEVEL (V/m)
385	380–390	TETRA 400	Pulse modulation b) 18 Hz	1.8	0.3	27
450	430–470	GMRS 460, FRS 460	FM c) ± 5 kHz deviation 1 kHz sine	2	0.3	28
710	704–787	LTE Band 13, 17	Pulse modulation b) 217 Hz	0.2	0.3	9
745						
780						
810	800–960	GSM 800/900, TETRA 800, ODEM 820, CDMA 850, LTE Band 5	Pulse modulation b) 18 Hz	2	0.3	28
870						
930						
1,720	1,700–1,990	G GSM 1,800, CDMA 1,900, GSM 1,900, DECT, LTE Band 1, 3, 4, 25; UMTS	Pulse modulation 217 Hz	2	0.3	28
1,845						
1,970						
2,450	2,450–2,570	Bluetooth WLAN, 802.11b/g/n, RFID 2,450, LTE Band 7	Pulse modulation b) 217 Hz	0.2	0.3	9
5,240	5,100–5,800	WLAN 802.11 a/n	Pulse modulation b) 217 Hz	0.2	0.3	9
5,500						
5,785						

-
- a) For some services, only the uplink frequencies are included
 - b) The carrier shall be modulated using a 50% duty cycle square wave signal.
 - c) As an alternative to FM modulation, 50% pulse modulation at 18 Hz may be used because, while it does not represent actual modulation, it would be the worst case.
-

This table lists the immunity levels at specific test frequencies for a Proximity Magnetic Fields Range of 9 kHz to 13.56 MHz.

Test Frequency	Modulation	Immunity Test Level (A/m)
30 kHz a)	CW	8
134.2 kHz	Pulse modulation b) 2.1 kHz	65 c)
13.56 MHz	Pulse modulation b)	7.5 c)

- a) This test is applicable only to ME equipment and ME systems intended in a HOME HEALTHCARE ENVIRONMENT.
 - b) The carrier shall be modulated using a 50% duty cycle square wave signal.
 - c) RMS before modulation is applied.
-

Note: These guidelines may not apply in all situations. Electromagnetic propagation is affected by absorption and reflections from structures, objects and people.

Field strengths from fixed Transmitters, such as base stations for radio (mobile/wireless) telephones and land mobile radios, amateur radio, AM and FM radio broadcast, and TV broadcast, cannot be predicted theoretically with accuracy. In order to assess the electromagnetic environment due to fixed RF Transmitters, an electromagnetic site survey should be considered. If the measured field strength in the location in which the equipment is used exceeds the applicable RF compliance level above, the equipment should be observed to verify normal operation. If abnormal performance is observed, additional measures may be necessary, such as reorienting or relocating the equipment.

Customer's Bill of Rights

Mission Statement

Insulet Corporation is dedicated to designing, developing and distributing products that provide superior treatment options and lifelong health benefits for people with diabetes.

Scope of Services

Insulet Corporation's scope of services is limited to providing the Omnipod 5 Automated Insulin Delivery System.

The Omnipod 5 System consists of the Pod and the handheld, wireless Controller, which programs the Pod with insulin delivery instructions.

Compliance

The Omnipod 5 Automated Insulin Delivery System is manufactured and distributed by Insulet Corporation. The company is committed to complying with all national and local regulations. If you have any questions or concerns regarding any of our activities, please contact us on 1-800-591-3455 (from outside the United States, 1-978-600-7850).

Inquiries

Representatives are available to answer product-related inquiries 24 hours per day at our freephone number, 1-800-591-3455 (from outside the United States, 1-978-600-7850). For all other questions, concerns or complaints, please contact us between the hours of 08:30 and 18:00 Eastern Time, Monday to Friday, on 1-800-591-3455 (from outside the United States, 1-978-600-7850). We will respond immediately whenever possible; some issues may take up to 14 days to resolve.

CHAP-Accredited

Insulet Corporation has been accredited by the Community Health Accreditation Programme (CHAP) since 2007. To learn more about CHAP or to communicate concerns that you have been unable to resolve directly with the company, please visit www.chapinc.org or call CHAP on 1-800-656-9656.

Customer's Bill of Rights and Responsibilities

You have the right to:

1. Receive considerate and respectful service.
2. Receive service without regard to race, creed, national origin, sex, age, disability, sexual orientation, illness or religious affiliation.
3. Expect confidentiality of all information pertaining to you, your medical care and service. Please review our HIPAA Privacy Notice later in this section.

4. Receive a timely response to your request for service.
5. Receive continued service.
6. Select the medical equipment supplier of your choice.
7. Make informed decisions regarding your care planning.
8. Understand what services will be provided to you.
9. Obtain an explanation of charges, including policy for payment.
10. Agree to or refuse any part of the plan of service or plan of care.
11. Voice complaints without fear of termination of service or other reprisals.
12. Have your communication needs met.

You have the responsibility to:

1. Ask questions about any part of the plan of service or plan of care that you do not understand.
2. Use the equipment for the purpose for which it was prescribed, following instructions provided for use, handling care, safety and cleaning.
3. Supply Insulet Corporation with insurance information necessary to obtain payment for services.
4. Be accountable for charges not covered by your insurance. You are responsible for settlement in full of your account.
5. Notify us immediately of:
 - a. Equipment failure, damage, or need of supplies.
 - b. Any change in your prescription or physician.
 - c. Any change or loss in insurance coverage.
 - d. Any change of address or telephone number, whether permanent or temporary.

Limited Express Warranty, Disclaimer, and Limitation of Remedies for the Controller and Pods

LIMITED EXPRESS WARRANTY, DISCLAIMER OF IMPLIED WARRANTIES AND LIMITATION OF REMEDIES FOR THE OMNIPOD 5 AUTOMATED INSULIN DELIVERY SYSTEM HANDHELD CONTROLLER AND PODS

LIMITED EXPRESS WARRANTY COVERAGE

Limited Warranty Coverage for the Omnipod 5 Automated Insulin Delivery System Handheld Controller (“Controller”)

Subject to the terms and conditions stated herein (“Limited Express Warranty”), the Insulet entity that either (i) provided this Controller to you or (ii) made this Controller available in the country in which you received it (each referred to as “Insulet”) warrants to you, the original recipient of the Omnipod 5 Automated Insulin Delivery System (“Omnipod 5 System”), that, if Insulet determines, during the period of either four (4) years (for all countries except for Canada) or five (5) years (for Canada) from the date of purchase (or receipt where purchased on your behalf), that the Controller included in your shipment manifests a defect in material or workmanship while utilised under normal use and conditions, Insulet will either repair or replace, at its sole option, the Controller. If Insulet chooses to repair the Controller, Insulet may choose to do so by implementing a software update, including an over-the-air software update, without further notice to the original purchaser. If Insulet chooses to replace the Controller, Insulet may choose to do so by replacing the Controller with an updated Controller.

The applicable warranty period applies only to new Controllers and, in the event the Controller is repaired or replaced, the warranty period will not be extended or reset. Thus, if Insulet replaces a Controller under this Limited Express

Warranty, the warranty coverage for the replacement Controller will expire four (4) years (for all countries except for Canada) or five (5) years (for Canada) from the date of purchase of the original Controller.

Limited Warranty Coverage for the Omnipod 5 Automated Insulin Delivery System Pods

Subject to this Limited Express Warranty, Insulet warrants to you, the original purchaser of the Omnipod 5 Automated Insulin Delivery System, that, if Insulet determines, during the period of eighteen (18) months from the date of manufacture and seventy-two (72) hours from the time of activation, that an unexpired Omnipod 5 Automated Insulin Delivery System Pod (“Pod”) included in your shipment manifests a defect in material or workmanship while utilised under normal use and conditions, Insulet will replace the Pod. To be eligible

for replacement, the activation of the Pod must fall within both time periods (i.e., occur on or before the expiry date printed on the label with a manufacture date no more than eighteen (18) months before and on or before a time no more than seventy-two (72) hours before you notify Insulet of the claim).

These eighteen (18) month and seventy-two (72) hour warranty periods apply only to new Pods and, in the event a Pod is replaced, the warranty period shall not be extended or reset. Thus, if Insulet replaces a Pod under this Limited Express Warranty, the warranty coverage for the replacement Pod shall expire either eighteen (18) months from the manufacture date of the original Pod or seventy-two (72) hours from the time of activation of the original Pod, whichever occurs first.

LIMITED EXPRESS WARRANTY TERMS AND CONDITIONS

This Limited Express Warranty applies only to Controllers and Pods that were originally sold for use in the country in which you purchased or received the applicable product (the

“Territory”). Insulet will only ship repaired or replaced Controllers and Pods and provide warranty services within the Territory.

Claim Procedure

To be eligible to claim under this Limited Express Warranty, you must notify Insulet of the claimed defect with the Controller or the Pod within the applicable warranty period by calling the applicable Insulet Customer Care number found on our website or in the product *Technical User Guide*. For a claim involving the Controller, you must provide the Controller serial number and a description of the claimed defect. For a claim involving a Pod, you must provide the Pod lot number and a description of the claimed defect. You may also be required to verify the date of purchase (or receipt where purchased on your behalf) of the Controller and/or the Pod and the time that you activated the Pod.

Your failure to follow any of the above steps may result in the denial of coverage under this Limited Express Warranty.

Unless Insulet elects to repair the Pod or the Controller (which may include, but is not limited to, a repair kit or replacement part(s) Insulet provides) or refers you to a third-party repairer, you must obtain Insulet’s authorisation prior to returning the Pod or the Controller to Insulet. The Pod or Controller must be properly packaged and returned to Insulet according to the instructions provided in the Return Merchandise Authorisation (RMA) Kit, which will be sent to you by Insulet. With a prior authorisation, Insulet will pay all reasonable packaging and postage charges, where applicable, incurred in shipping the Pod or the Controller to Insulet under this Limited Express Warranty. For the avoidance of doubt, this Limited Express Warranty does not cover repairs performed or replacements provided by any person or entity other than Insulet, except those performed or provided by third parties to which you were explicitly referred by Insulet.

Proof of Purchase

In order to verify the date of purchase (or receipt where purchased on your behalf), the date of manufacture, or the time of activation and to determine if the claim under this Limited Express Warranty is within the applicable warranty periods, Insulet may require that you provide a valid proof of purchase, manufacture or activation. Your failure to provide valid proof of purchase, manufacture or activation, as determined by Insulet, may result in the denial of coverage under this Limited Express Warranty.

Exclusions

This Limited Express Warranty covers only the original purchaser and cannot be transferred or assigned with the sale, rental or other transfer of the Controller or of the Pod to any other person or entity.

This Limited Express Warranty will apply only if the Controller or the Pod at issue has been used in accordance with the Omnipod 5 Automated Insulin Delivery System *Technical User Guide* and/or other written instructions provided by Insulet. THIS LIMITED EXPRESS WARRANTY DOES NOT APPLY IF THE CONTROLLER OR THE POD HAVE BEEN:

- Altered, changed or modified by any person or entity other than Insulet;
- Opened, serviced or repaired by any person or entity other than Insulet;
- Damaged by an act of God or other “force majeure”-like event;
- Damaged by misuse, abuse, negligence, accident, unreasonable use, or improper handling, care or storage;
- Damaged by wear and tear, causes unrelated to defective materials or workmanship (including without limitation unsuitable or faulty batteries or sim cards) or other circumstances outside of the reasonable control of Insulet.

This Limited Express Warranty does not apply to sim cards, test strips, or batteries that are not provided by Insulet, other accessories, or related products provided by third parties (e.g., data management tools, Sensors).

This Limited Express Warranty does not extend to design defects (i.e. claims that the Controller or the Pod should have been designed in a different way).

DISCLAIMER OF IMPLIED WARRANTIES AND LIMITATION OF REMEDIES

To the extent permitted by law in the country you purchased or received the Controller and Pods:

- This Limited Express Warranty and the remedies set out in it are the only warranties and remedies provided by Insulet to you in relation to the Controller and the Pods and all other statutory and implied warranties are expressly excluded to the maximum extent permitted.
- Insulet, its suppliers, distributors, service providers, and/or agents will not be liable for indirect, special, incidental or consequential damages caused by a defect in the Controller or a Pod or by a breach of this Limited Express Warranty, whether such claim is based in warranty, contract, tort or otherwise.

Nothing in this Limited Express Warranty is intended to exclude our liability for death or personal injury resulting from our negligence, for fraud or fraudulent misrepresentation, or for breach of your statutory rights in relation to the Controller or Pods.

Important Additional Provisions

This Limited Express Warranty affords you specific legal rights. You may also have other statutory rights which vary by jurisdiction.

Your statutory rights are not affected by this Limited Express Warranty.

Insulet does not warrant the suitability of the Controller or the Pods or the Omnipod System for any specific person as healthcare and treatment are complex subjects requiring the services of qualified healthcare provider.

This Limited Express Warranty is between you and Insulet. No other party has any rights to enforce any of its terms. Insulet may transfer its rights and obligations under this Limited Express Warranty to another party without your consent.

If any provision of this Limited Express Warranty is found to be invalid by any court, that provision will be deemed to be deleted from this Limited Express Warranty and the validity of the remaining provisions will not be affected.

No Other Warranty or Agreement

Unless modified in writing and signed by both Insulet and you, the foregoing Limited Express Warranty is understood to be the complete and exclusive understanding between Insulet and you, superseding all prior warranties and agreements, oral or written, and all other communications relating to any defect in, failure or other malfunction in a Controller, a Pod, or an Omnipod 5 Automated Insulin Delivery System. No employee, agent or other representative of Insulet or any other party is authorised to make any product warranty or agreement applicable to a Controller, a Pod, or an Omnipod 5 Automated Insulin Delivery System in addition to those made in the foregoing.

Consent to Disclaimer of Implied Warranties and the Limitation of Remedies

If you do not consent to and, instead, wish to reject the Disclaimer of Implied Warranties and the Limitation of Remedies included with the Omnipod 5 Automated Insulin Delivery System, please return any Omnipod 5 Automated Insulin Delivery System products (including any

Controller and Pods) to Insulet in exchange for a full refund. Failure to return such Omnipod 5 Automated Insulin Delivery System products shall constitute acknowledgement of and consent to the Disclaimer of Implied Warranties and the Limitation of Remedies.

Governing Law and Jurisdiction

This Limited Express Warranty (and any non-contractual obligations arising out of or in connection with it) is governed by the laws of the country in which you initially purchased or received the Controller or Pods. Any court of competent jurisdiction in such country will have exclusive jurisdiction and venue for any dispute arising out of or in connection with this Limited Express Warranty.

Rev: January 2022

Medical Device Regulation

Insulet complies with Medical Device Regulation 2017/745.

EU Authorised Representative details

Contact Person: The Complaints Officer

Address: Insulet Netherlands B.V., WTC Utrecht Stadsplateau 7,
Suite 7.06,
3521 AZ Utrecht, The Netherlands

TEL.: +31 308 990 670

Email: ECRep@insulet.com



This page intentionally left blank.

Index

A

- About screen 54
- Action Item notifications
 - Connect to a Wireless Network 172
 - Omnipod 5 Error 174
- active insulin. *See* Insulin on Board
- Activity feature
 - cancel 323
 - enable 323
- Adaptivity 311
 - Adaptive Basal Rate 306–307
- adhesive 88
- Advisory Alarms
 - Automated Delivery Restriction 326
 - Low Pod Insulin 166
 - Missing Sensor Glucose Values 328
 - Pod Expired 167
 - Pod Shut-Off 168
 - Start Insulin 169
 - Urgent Low Glucose 170
- air bubbles 81
- airport security 195
- alarms
 - advisory 326–329
 - check or test 157
 - hazard 158–165
 - Silencing 179
- Automated Mode
 - Automated Delivery Restriction alarm 326
 - enter 318
 - Limited 312
 - switching to Manual Mode 320

B

- basal history records 136–144
- Basal Programme
 - about 100
 - create new 97
 - delete 98
 - edit 97
 - rename 97
 - switch 98
- basal rate 100
 - flow accuracy 383
- Basal Rate
 - Maximum, setting 130
- basal segment 100
- battery, Controller
 - charge 189
 - preserve 124
- blockage (occlusion)
 - detection 387
- Bluetooth
 - Controller 123
- Bolus Calculator
 - disabled 235
 - sample calculations 244
 - using Sensor 221
- bolus, extended
 - cancel 216
 - deliver 225
 - progress 215
 - setting 229
- bolus, immediate
 - cancel 216
 - deliver 224
 - flow rate 383
 - progress 214
- Boot Mode 379
- brightness, screen 124

C

- cancel
 - bolus 216
- cannula 89, 382
- carb-to-insulin ratio.. *See* IC Ratio
- change Pod. *See* activate Pod
- check alarm function 157
- cleaning
 - Controller 187
 - Pod 185
- confidence Reminders
 - beeps 154
- confirmation messages 55
- Controller 41
 - Controller PIN 64
 - diagram 41
 - dropped or damaged 188
 - electrical interference 186
 - replacement 187
 - screen time-out 124
 - setting up 60, 62
- Controller battery
 - how to charge 189
- Correct Above threshold 230, 236
- Correction Factor 231, 235
- correction IOB 236, 243
- create
 - new Basal Programme 97
 - Temp Basal Preset 105
- CT scans 205

D

- damaged Controller 188
- Dashboard tab 45
- data entry, how to 34
- Daylight Saving Time 173
- default settings 381
- diabetic ketoacidosis 78, 203
- diagnostic functions
 - check alarms 157
- dropped Controller 188
- Duration of Insulin Action
 - sample calculations 243–244
 - setting 232

E

- edit existing Basal Programme 97
- edit existing Temp Basal Preset 106
- electrical interference 186
- electrical safety 396
- electromagnetic compatibility 396
- emergency kit 194
- enter Automated Mode 318
- entering text 34
- estimated bolus 142
- exercise 205
- expiry, Pod 128, 182
 - Advisory Alarm 167
- Extended Bolus
 - cancel 216
 - deliver 225
 - progress 215
 - setting 130, 229

F

- first Pod in Automated Mode 318
- flat rate (U/hr) setting
 - change setting 130
 - Temp Basal 108
- flight mode setting 123
- flow rate accuracy 383
- FreeStyle Libre 2 Plus 40, 269

G

- glucagon kit 15, 198
- Glucose
 - HIGH and LOW results 114, 259
 - Target Glucose 236–250
 - urgent low glucose alert 170

H

- Hazard Alarms
 - Blockage Detected 158
 - Omnipod 5 App Error 159
 - Omnipod 5 Memory Corruption 160
 - Pod Error 161
 - Pod Expired 162

- Pod Out of Insulin 163
- Pod Shut-Off 164
- System Error 165
- history records
 - carbs 136–144
 - glucose 136–144
 - insulin, basal and bolus 136–144
- holiday 195
- hospitalisation 206
- hyperglycaemia
 - avoiding 200
 - symptoms 200
 - treating 202
- hypoglycaemia 197–201
 - avoiding 198
 - symptoms 197
 - treating 199

I

- IC Ratio 231, 235
- illness 204
- indications for use 6
- infusion site
 - guidelines for selection 84
 - preparation 86
- insulin
 - history records 136–144
 - rapid-acting vs long-acting 203
 - storage 184
- insulin action. *See* Duration of Insulin Action
- Insulin on Board (IOB) 236
- Insulin-to-Carb Ratio.. *See* IC Ratio

K

- ketones 203

L

- Limited 312
- liquid (water) and the Controller 186
- Lock screen
 - change background 124
 - change message 124
 - lock 42

- message 124
- unlock 42
- low battery
 - recharging 189
- low Pod Insulin setting 128

M

- Manual Mode
 - switching to Automated Mode 318
- map of Pod sites
 - using 85
- Maximum Basal Rate setting 130
- Maximum Bolus
 - setting 229
 - understanding 234
- maximum insulin amount 80
- meal IOB 234, 243
- microwave ovens 186
- minimum insulin amount 80
- modes
 - available tasks within 56
- MRIs 205

N

- navigation shorthand 36
- network connectivity 123
- new Basal Programme 97
- not compatible
 - device 174
- Notifications
 - Action Item notification. *See* Action Item notifications

O

- operating temperature 186, 382
- orientation, Pod 88

P

- pause insulin delivery 117
 - while editing a Basal Programme 97
- per cent setting

- change setting 229
 - Temp Basal 108
 - physical exertion 205
 - PIN
 - forgot 43
 - reset 125
 - playing sports 205
 - Pod
 - activation 78
 - cleaning 185
 - deactivate 91
 - expiry setting 128
 - flow accuracy 383
 - flow rate 383
 - low Pod insulin setting 128
 - orientation 88
 - Shut-off setting 128
 - site selection 84, 88
 - specifications 382
 - storage 184
 - Pod expired alarm 167
 - Pod shut-off Advisory Alarm. *See* Advisory Alarms: Pod Shut-Off
 - Pod shut-off hazard alarm. *See* Hazard Alarms: Pod Shut-Off
 - Pod site map 85
 - prepare infusion site 86
 - Product Support. *See* Customer Care
 - programme Reminder setting 129
- ## R
- Reminders
 - Programme 129
 - Reverse Correction 232, 237, 245
- ## S
- safety
 - automatic checks 83
 - electrical 396–407
 - screen
 - brightness 124
 - protector 34
 - sensitivity 34
 - time-out 124
 - security
 - Controller 64
 - Sensor
 - Dexcom Issue Detected 261
 - FreeStyle Libre 2 Plus 40, 269
 - missed values Advisory Alarm 328
 - Transmitter Error 262
 - Transmitter Not Found 262
 - set Temp Basal
 - activating 103
 - settings
 - Bolus Calculator 230–232
 - Correct Above 230
 - Correction Factor 231
 - Duration of Insulin Action 232
 - Extended Bolus configuration 229
 - flight mode 123
 - IC Ratio 231
 - lock screen image 124
 - lock screen message 124
 - low Pod insulin 128
 - Maximum Basal Rate 130
 - Maximum Bolus 229
 - PIN 125
 - Pod expiry 128
 - Pod Shut-Off 128
 - programme Reminders 129
 - Reverse Correction 232
 - screen brightness 124
 - screen time-out 124
 - summary 381
 - Temp Basal 130
 - set up Controller 62
 - set up new Pod 78
 - shorthand for navigation 36
 - sick days 204
 - site selection, Pod 84
 - specifications, technical
 - Pod 382
 - sports 205
 - start insulin delivery 120, 169
 - stop (pause) insulin delivery 118
 - storing Controller 185
 - specifications 384
 - storing Pod
 - location 184

- specifications 382
- supplies
 - Controller setup 61
 - obtaining 61
 - travel 194
- surgery 206
- suspend (pause) insulin delivery 119
- swimming 185
- Switching modes
 - from Automated to Manual 319
- symbols on labels 392
- symptoms
 - DKA 203
 - hyperglycaemia 200
 - hypoglycaemia 197
- system modes. *See* modes

T

- Target Glucose 230
- Temp Basal
 - activate or set 103
 - preset. *See* Temp Basal Preset
 - setting 130
 - set to zero 103, 119
 - understanding 107–110
- Temp Basal Preset
 - Creating a New Temp Basal Preset 105
 - Deleting a Temp Basal Preset 107
 - Editing or Renaming a Temp Basal Preset 106
- temperature
 - Controller storage 186
 - insulin 79, 184
 - Pod 79, 382
- text, entering 34
- time-out, Controller screen 124
- touchscreen 33
 - brightness 124
 - sensitivity 34
 - time-out 124
- travel 195–196

U

- unconfirmed bolus 142
- unlock
 - Controller 42
- Urgent Low Glucose
 - Advisory Alarm 170

V

- vibration or sound
 - notifications 153

W

- wake up Controller 42
- warranty 404
- water
 - and the Controller 186
 - and the Pod 185

X

- X-rays 195

Correction Factor

Correction Factor for each time segment	1 unit of insulin decreases glucose by
midnight to _____	_____ mmol/L
_____ to _____	_____ mmol/L
_____ to _____	_____ mmol/L
_____ to _____	_____ mmol/L
_____ to _____	_____ mmol/L
_____ to _____	_____ mmol/L
_____ to _____	_____ mmol/L
_____ to _____	_____ mmol/L

Insulin-to-Carbohydrate Ratio (IC Ratio)

IC Ratio for each time segment	1 unit of insulin covers
midnight to _____	_____ g carb
_____ to _____	_____ g carb
_____ to _____	_____ g carb
_____ to _____	_____ g carb
_____ to _____	_____ g carb
_____ to _____	_____ g carb
_____ to _____	_____ g carb
_____ to _____	_____ g carb

Duration of Insulin Action

Time that insulin remains "active" in the body after a bolus _____ hrs

Temp Basal Presets

Name	Rate (circle measurement)
_____	_____ U/hr or %
_____	_____ U/hr or %
_____	_____ U/hr or %
_____	_____ U/hr or %
_____	_____ U/hr or %
_____	_____ U/hr or %
_____	_____ U/hr or %

Favorite Foods

Name	Grams of carbohydrates
_____	_____ g carb
_____	_____ g carb
_____	_____ g carb
_____	_____ g carb
_____	_____ g carb
_____	_____ g carb
_____	_____ g carb

Max Basal Rate

Upper limit for basal rates in a Basal Programme or Temp Basal ___ U/hr

Max Bolus

Maximum amount of insulin that you can request in a single bolus ___ U/hr

omnipod[®] 5

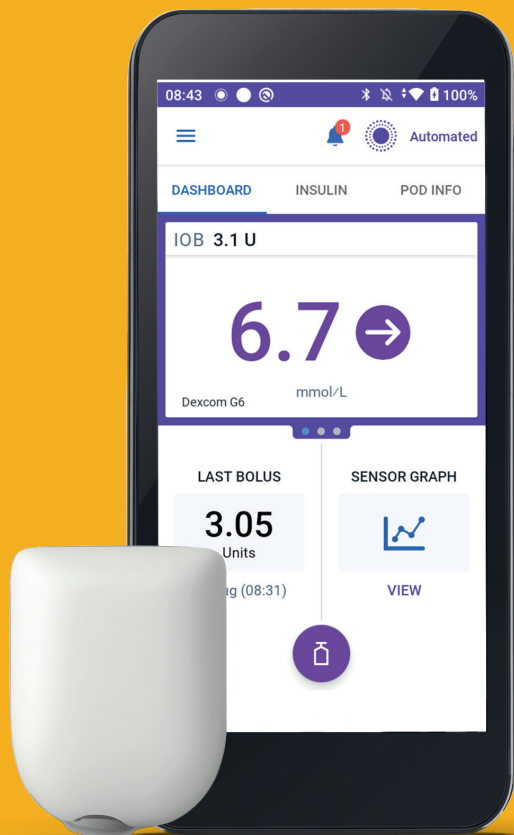

Pod shown without the necessary adhesive.



Insulet Corporation
100 Nagog Park
Acton, MA 01720, USA
1-800-591-3455 | 1-978-600-7850

omnipod.com



PT-000981

UK
CA
0086

MD

CE
2797

Reference #: PDM-M001-G-MM PT-000981-AW Rev. 04 11/24